

13-3430 Examining poly V-belt, damage patterns

Preceding work:
Hood raised to vertical position (01-0080).

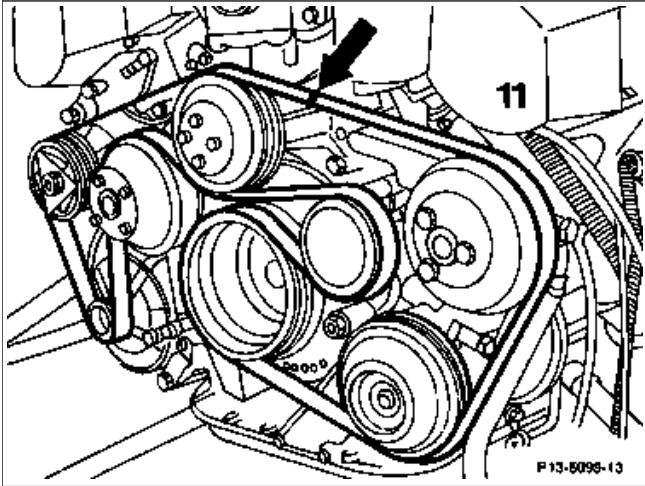

Examining

- Poly V-belt (11)..... mark with chalk at a clearly visible point (arrow).
- Engine..... crank with starter in stages (01-0110).
- Poly V-belt (11)..... examine for signs of damage.
- Examination..... ended once marking (arrow) is again visible (one full revolution of belt).

Damage patterns

The poly V-belt must be replaced (subject to separate repair order) if the following damage patterns are present:

- Rubber clumps in base of belt (C), dirt or grid embedded (D).

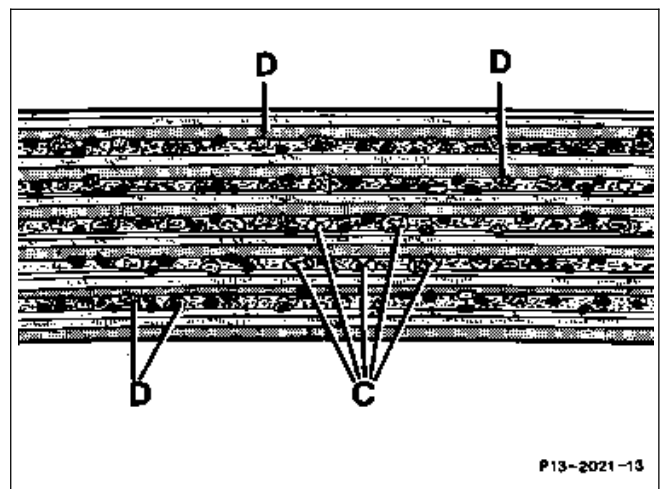

- Wear to flanks (F)
Ribs are pointed - trapezoidal in shape when new (E) and cord is visible in base of belt (G, lighter points).

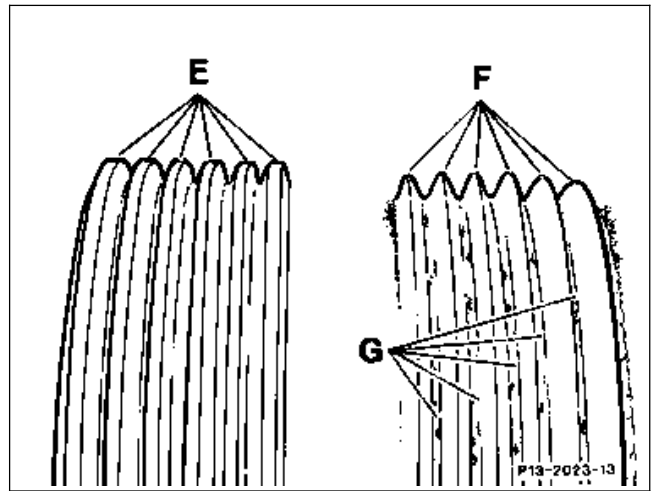

- Rib (arrow) detached from base of belt. Splitting across several ribs (H).

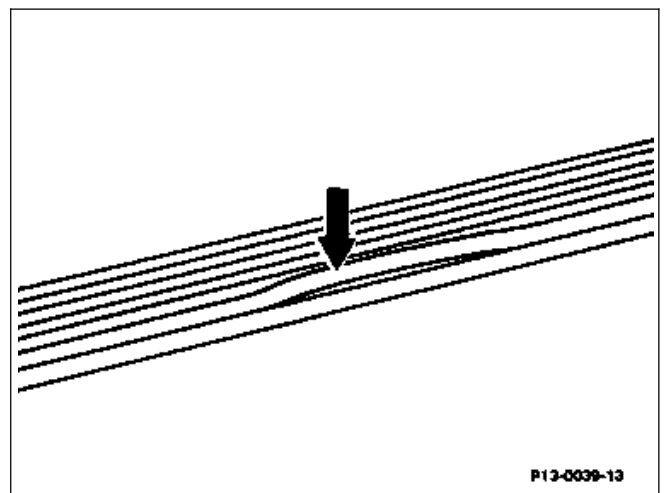

- Splitting across ribs (H) and/or sections of belt broken off (J).

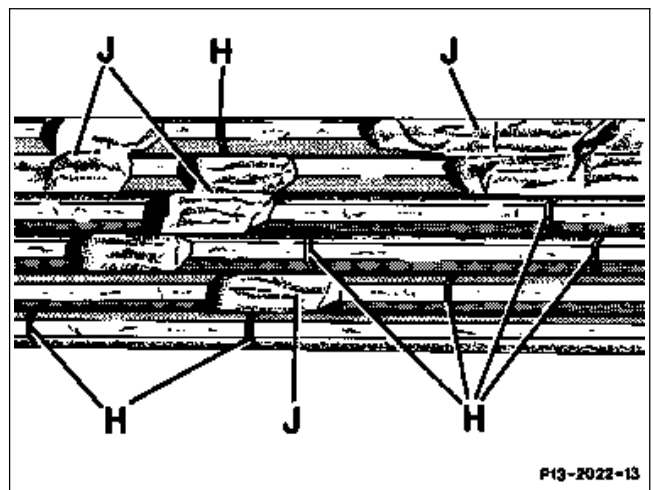

- Cord fractured at the side (K) or fraying (L) of outer cords.

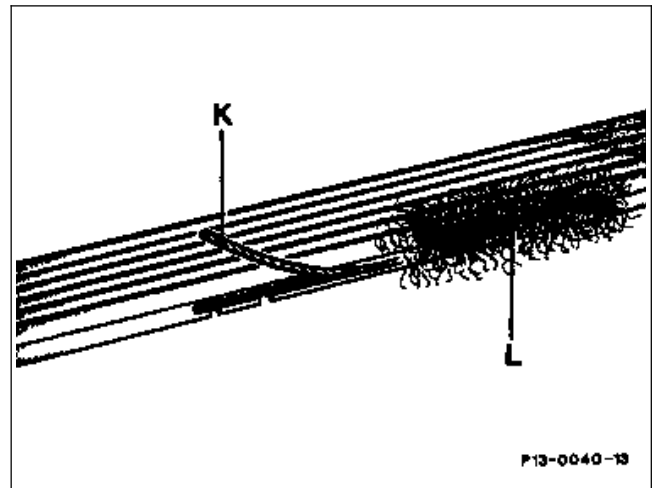

- Splitting across the back (M).

