

Specifications

Unloader Swing Fast Valve

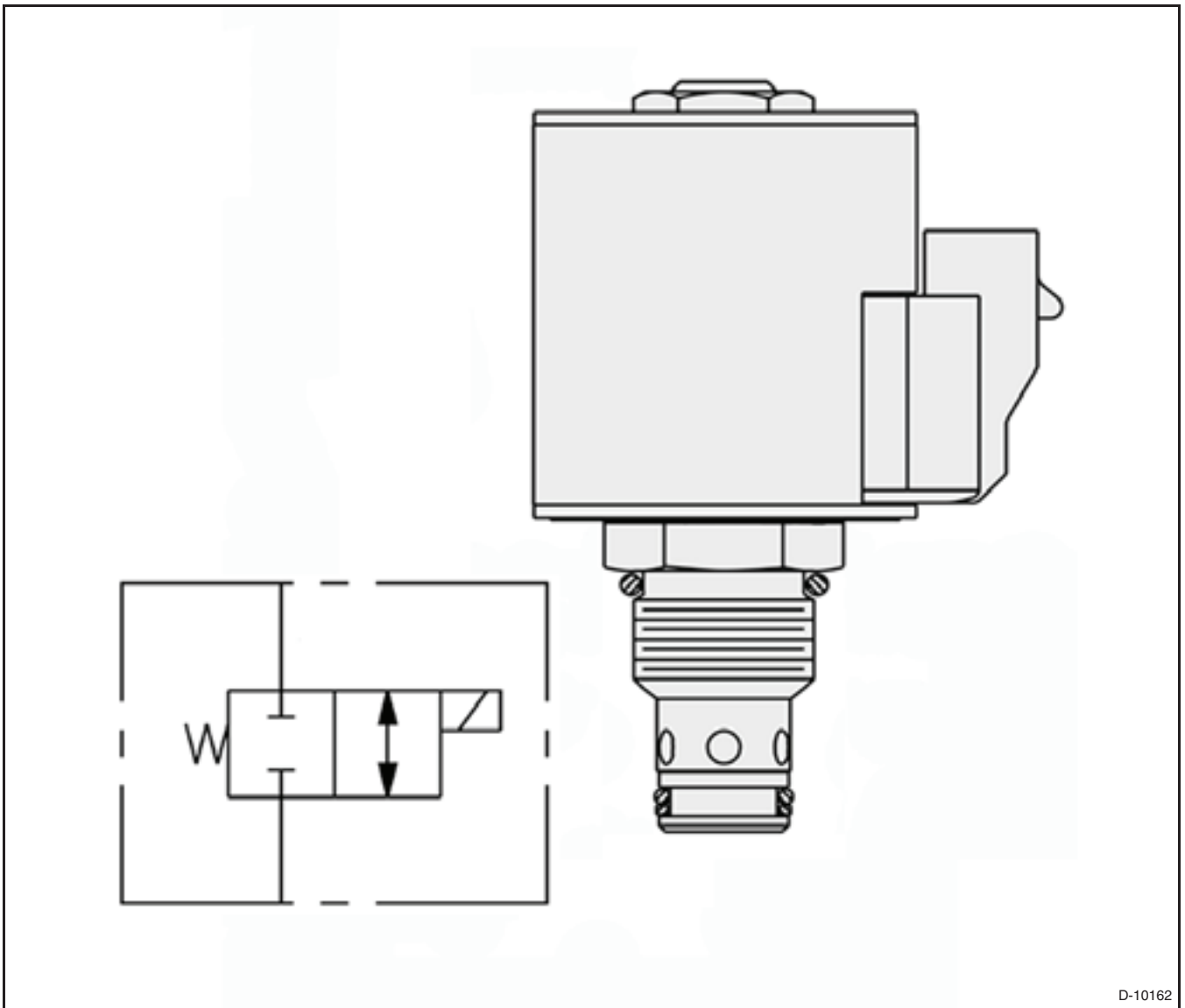

D-10162

FIG. 26

FIG. 26: Unloader Swing Fast Solenoid Valve

Make..... HydraForce
Model SV04-24
Type..... 2-Way Normally Closed Spool Valve
Flow..... 17 l/min (4.5 gal/min)
Operating Pressure 207 bar (3000 psi)

Header Lift Cylinders

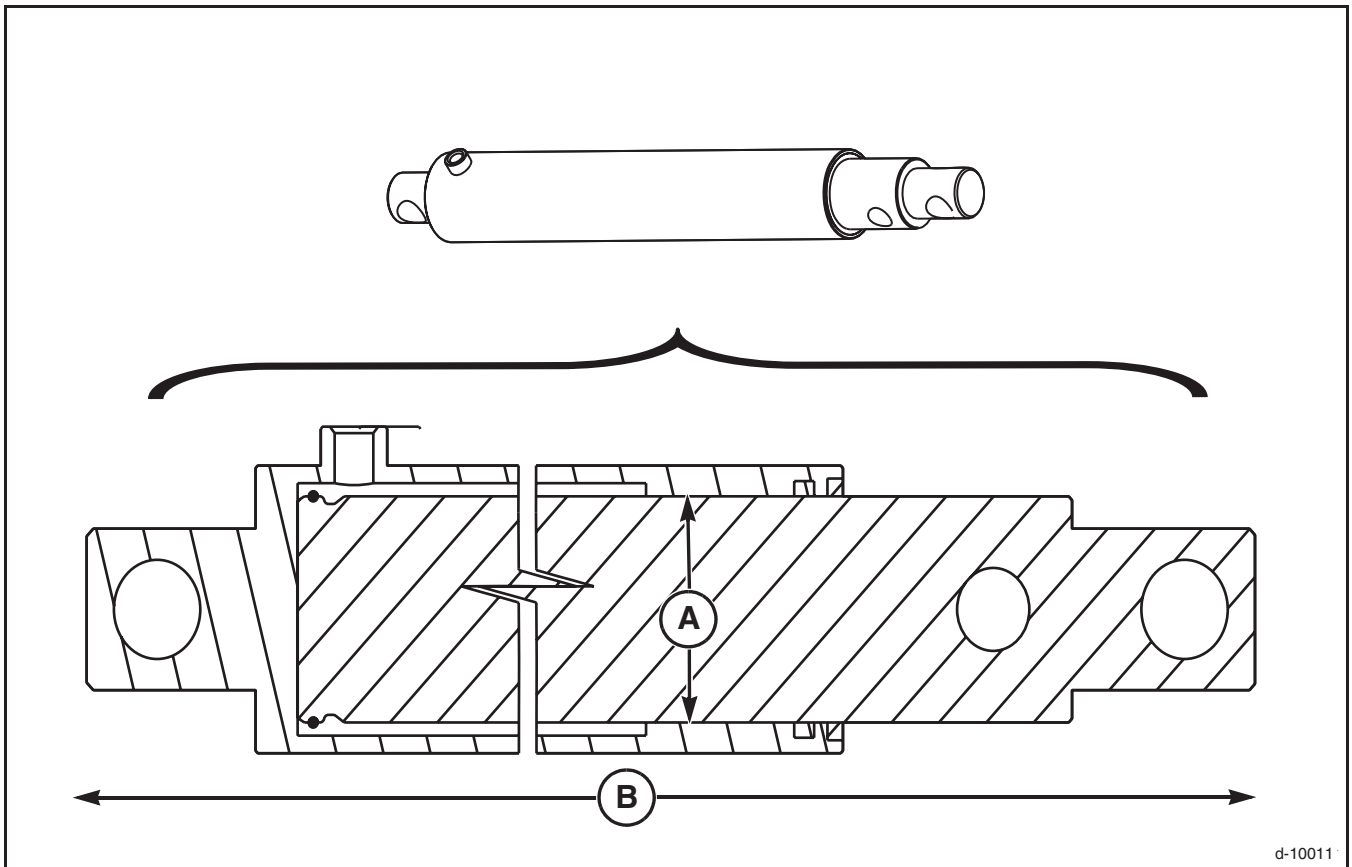

FIG. 27

FIG. 27: Header Lift Cylinder

Make.....	Hyco
Model	RCA - 39001 - 01967
Type.....	Hydraulic, Single Acting
Number	2 cylinders
Maximum Operating Pressure	200 bar (2900 psi)
Cylinder Rod Diameter (A)	88.9 mm (3.5 in)
Closed Length (B).....	815 mm (32.1 in)
Stroke	499.6 mm (19.7 in)