

ELECTRICAL SYSTEM

FUSE / CIRCUIT BREAKERS / RELAYS

FIG. 1: Power distribution center is located on right-hand side of cab. To gain access to components located here, loosen four thumb screws (1) from corners of cover.

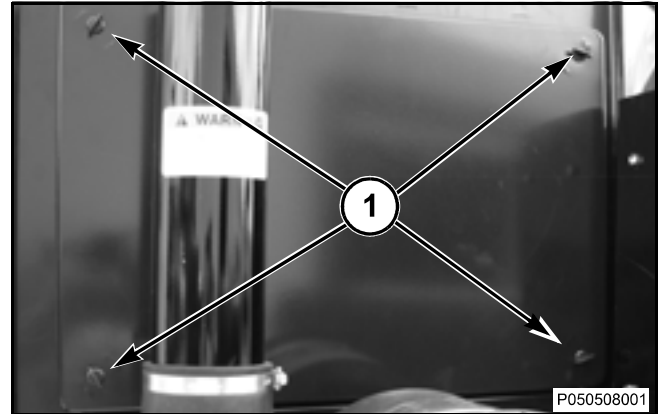

FIG. 1

FIG. 2: Power Distribution Module 1 (PDM1) (1) contains eleven fused circuits. Circuits one, two and three are unswitched power. Circuit two supplies power to ignition switch which supplies power to circuits four through eleven of PDM 1 and all of circuits in PDM 2 (2). Each PDM contains four socketed relays. In PDM1 each relay controls two fuses. In PDM2 each relay controls one fuse.

PDM 1 – Relay K1 controls fuses F6 and F7

PDM 1 – Relay K2 controls fuses F4 and F5

PDM 1 – Relay K3 controls fuses F10 and F11

PDM 1 – Relay K4 controls fuses F8 and F9

PDM 2 – Relay K1 controls fuse F1

PDM 2 – Relay K2 controls fuse F2

PDM 2 – Relay K3 controls fuse F3

PDM 2 – Relay K4 controls fuse F4

Each PDM contains four green light emitting diodes (LEDs) indicating that respective relays are providing switched power to fuses. There are also red LEDs next to each fuse. If red LED is illuminated, fuse has blown.

There are three relay modules located in power distribution center. First module, 4P1 (3), contains four normally open relays. Second module, 2P1 (4), and third module, 2P2 (5), both contain two relays each, which can operate either normally open or normally closed. All relays can source a maximum of 15 amps. There are green LEDs in each module indicating status of coil in relay.

Heating, Ventilation, and Air Conditioning (HVAC) relay (6) is located just behind relay modules. Below HVAC relay is four in-line 15 amp fuses. Power stud (7) supplies power to most of modules in power distribution center and adapter harness. Ground for these components comes from ground stud (8).

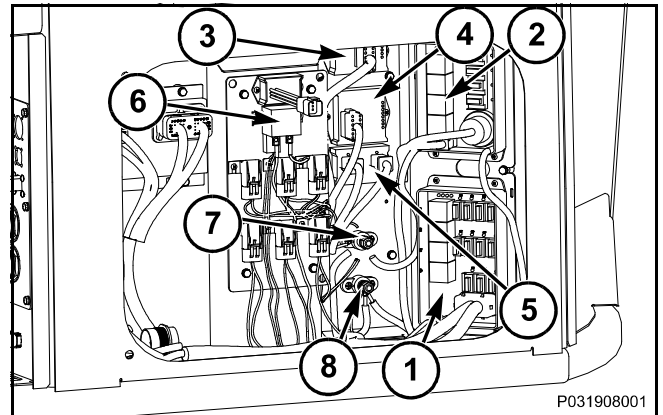

FIG. 2

Electrical System

CONTROLLER AREA NETWORK (CAN) COMPONENTS

Description

CAN is a serial data communications bus for real-time control of applications. In our applications there are four basic components necessary for a CAN system to operate: a master module, an I/O module, CAN backbone, and a terminator. CAN uses a single CAN cable to connect master module to I/O modules rather than hard wiring every component from beginning to end. It also provides a means for error codes to be generated.

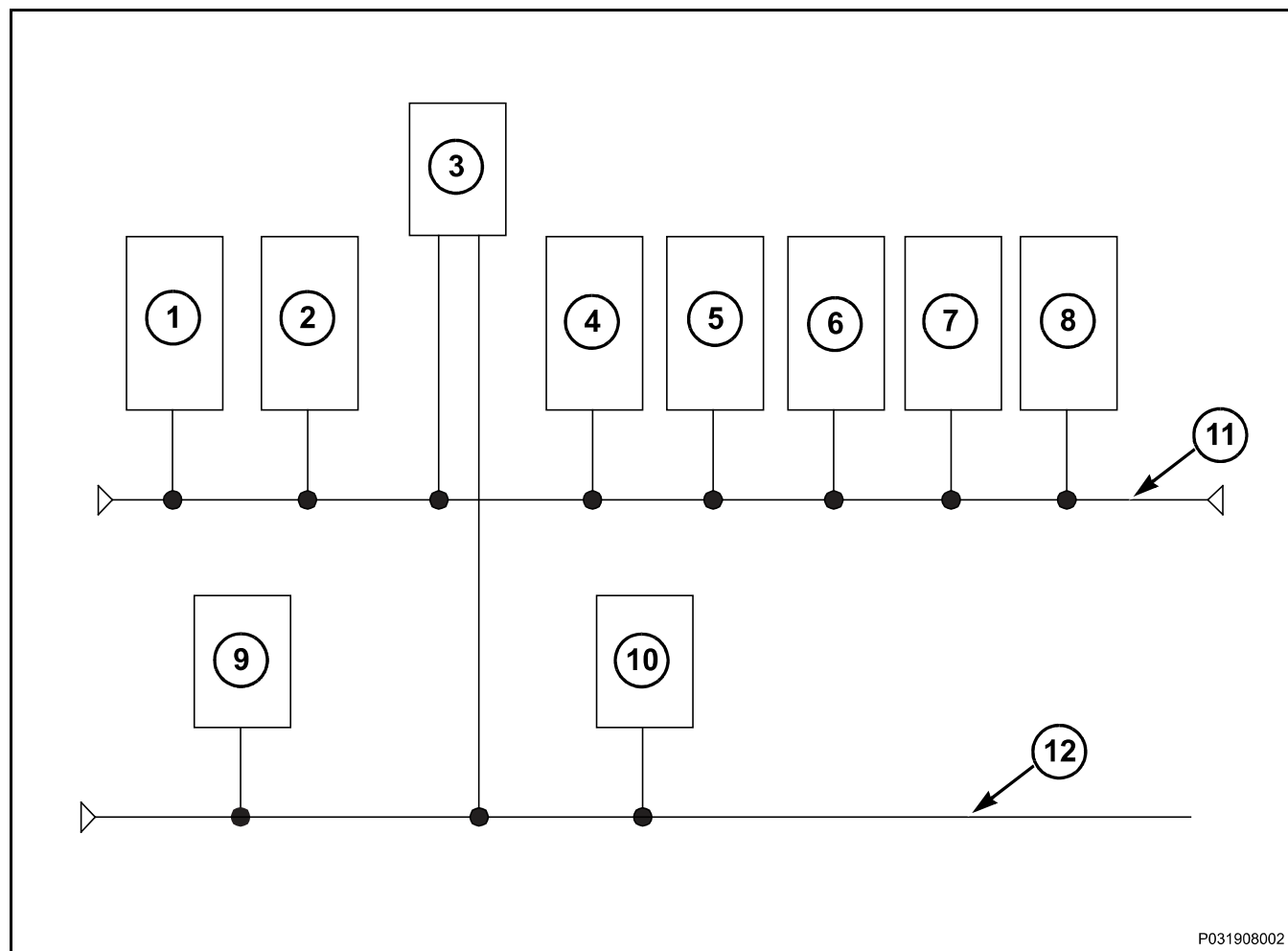

FIG. 3

FIG. 3: There are two CAN bus circuits on 7460/7660 series machines. CAN A bus circuit (11) operates all system and light functions.

- Track Adjust I/O Module 0 (1)
- Boom Section I/O Module 1 (2)
- Foam Marker I/O Module 2 (3)
- Front High Current I/O Module 3 (4)
- Rear High Current I/O Module 7 (5)
- Boom Motion I/O Module 4 (6)

- Boom Motion I/O Module 6 (7)
- Master Module (8)

CAN B bus circuit (12) communicates with engine and dash display. Both CAN bus circuits come from same master module.

- Engine ECM (9)
- Dash Display (10)