

**FLOAT/REEL VALVE ASSEMBLY**

**FIG. 8:** A valve body (1) with two solenoid valves is located on the Right-Hand end panel.

The valve body contains four ports:

(RL) Reel Lift and Lower - Line to the Right-Hand reel cylinder.

(FP) Float Pressure - Line to the Accumulator and the cutterbar float cylinders.

(P) Pressure - Line from the solenoid valve in reel circuit of the main control valve.

(G) Gage - Transducer GTA.

The two solenoid valves (2) and (3) are energized when adjusting the float pressure on the flex cutterbar. The solenoid valve (2) is energized and is functioning as a two-way check to maintain reel position. The solenoid valve (3) is energized and is open to allow oil to flow to and from the float cylinders and the accumulator. A 1.78 mm (0.070 in) orifice is in the cutterbar float circuit to control rate of pressure change when setting float pressure.

The solenoid valve (2) is open when de-energized and allows oil to flow to and from the reel cylinders when raising or lowering the reel. The solenoid valve (3) is de-energized and is functioning as a two-way check to maintain float pressure in the float cylinders and the accumulator.

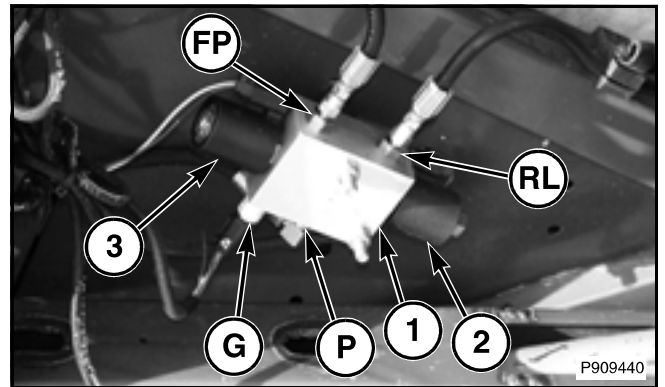

**FIG. 8**

**FIG. 9:** Valve Schematic

RL - Reel Lift Out

FP - Float Pressure Out

G - Gauge (Transducer)

SV1 - Solenoid Valve, Reel Lift

SV2 - Solenoid Valve, Float Pressure

ORFI - Orifice 1.78 mm (0.070 in)

P - Pressure In

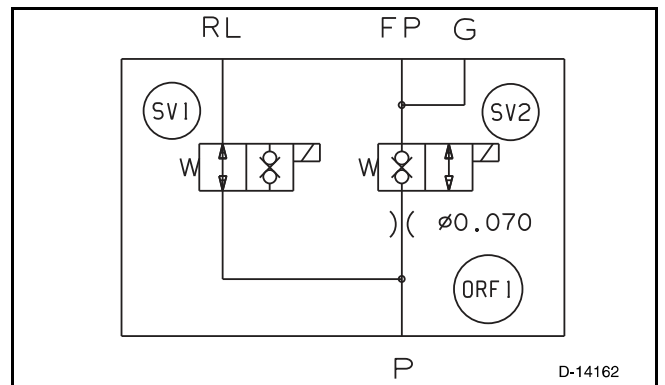

**FIG. 9**

# Hydraulics

## Operating Modes

### Float Pressure Increase/Decrease Valve

**FIG. 10:** The float valve is a solenoid operated, 2-way, normally closed, internally piloted, poppet-type, bi-directional blocking, screw-in hydraulic cartridge valve, designed for low leakage in load-holding applications.

When de-energized, the valve blocks flow in both directions. This holds pressure in the accumulator and the cutterbar float cylinders at the set point. Port 2 has float pressure around the port. Port 1 has reel lift pressure around the port.

When energized, using the cutterbar float switch on the control console, the valve's poppet opens on the valve seat, allowing flow from port 2 (2) to port 1 (1) or port 1 (1) to port 2 (2) allowing the set point to be changed using the reel lift/lower switch on the control handle along with the cutterbar float switch in the control console.

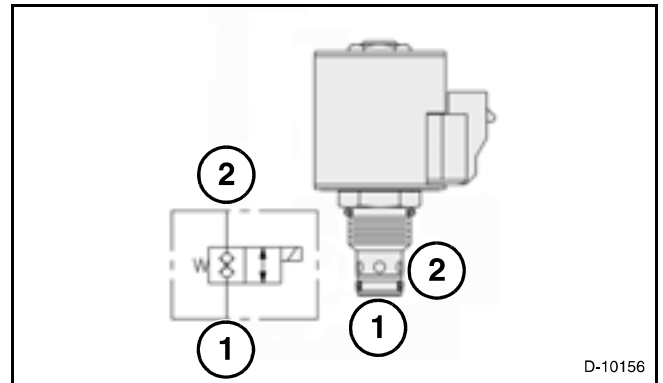

**FIG. 10**

### Reel Lift/Lower Valve

**FIG. 11:** The reel lift valve is a solenoid operated, 2-way, normally open, internally piloted, poppet-type, bi-directional blocking, screw-in hydraulic cartridge valve, designed for low leakage in load-holding applications.

When de-energized, the valve allows flow in both directions. The valve's poppet is open on the valve seat, allowing flow from port 2 (2) to port 1 (1) or port 1 (1) to port 2 (2) allowing the reel set height to be changed using the reel lift/lower switch on the control handle.

When energized, using the cutterbar float switch on the control console, the valve blocks flow in both directions. This holds pressure in the reel lift cylinder, keeping the reel at the set height. Port 2 has reel lift pressure around the port. Port 1 has float pressure around the port.

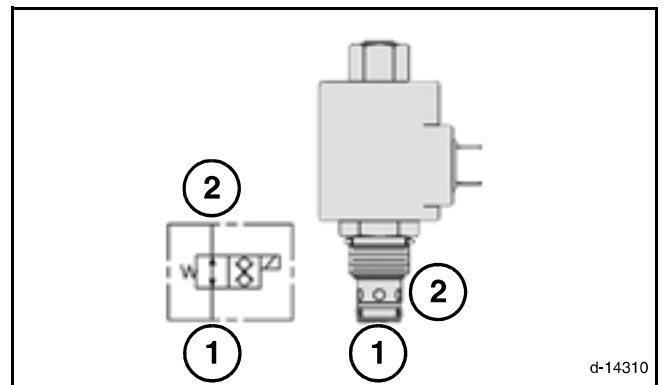
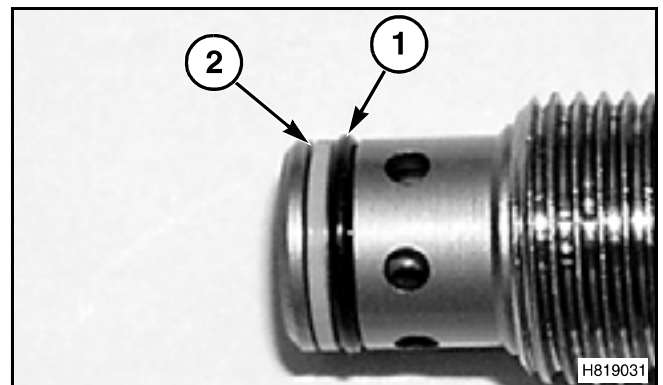

**FIG. 11**

### O-ring and Backup Rings

Any time a cartridge valve is removed from the valve block, inspect the O-rings and the backup rings. Replace any O-rings or backup rings that are cut or damaged and inspect the bore in the valve block for damage.

**FIG. 12:** The O-ring (1) is put on the high-pressure port side. The backup ring (2) is put on the low-pressure port side.



**FIG. 12**