

6.1.7 Assemble the pivot for the gauge wheel arm

Procedure

1. Install the rod (1). Make sure that the rod is in the center of the row unit.

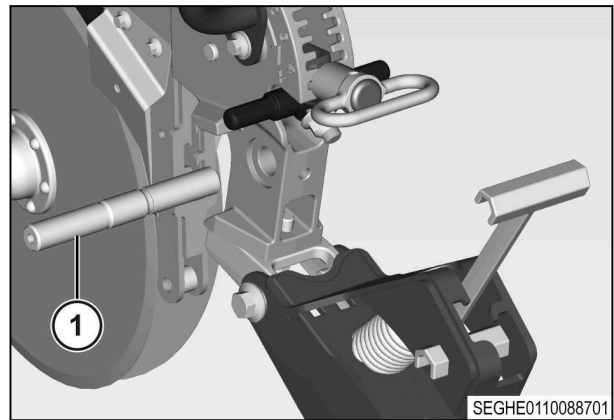

Fig. 18

2. Install the set screw (1).

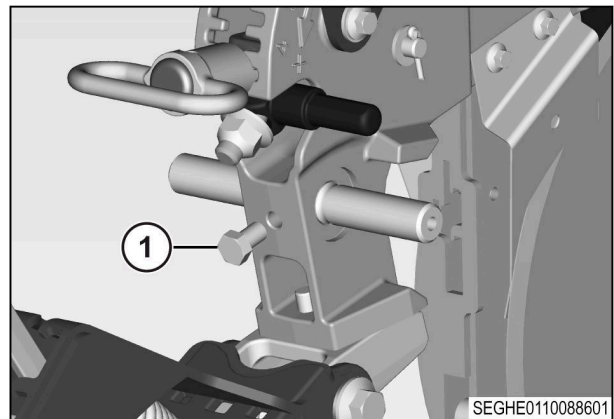

Fig. 19

3. Install the bushing (1) on the sides of the row unit.

NOTE:

Turn the bushing clockwise to tighten the bushing.

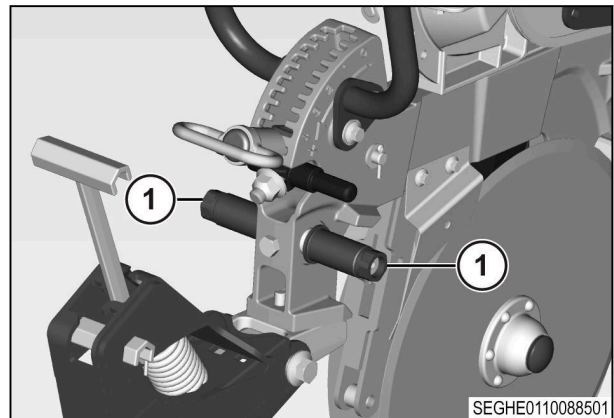

Fig. 20

4. Install the lock bolts (1) and washers (2).
Make the lock bolts hand tight.

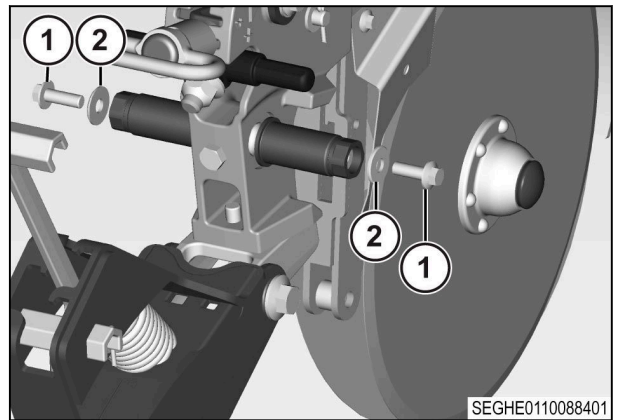

Fig. 21

5. Press the two bearings (1) into the wheel arm assembly (2).

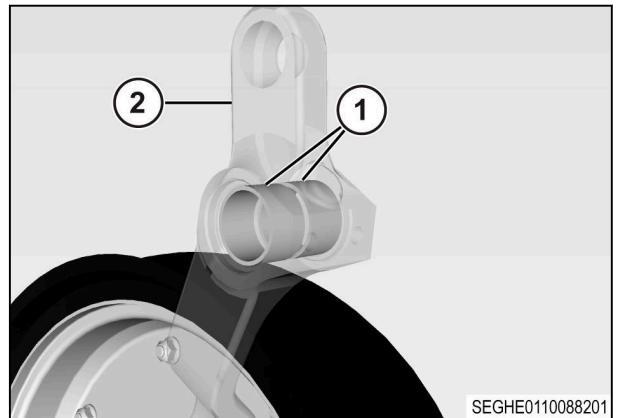

Fig. 22

6. Install the outer seal (1) and inner seal (2).

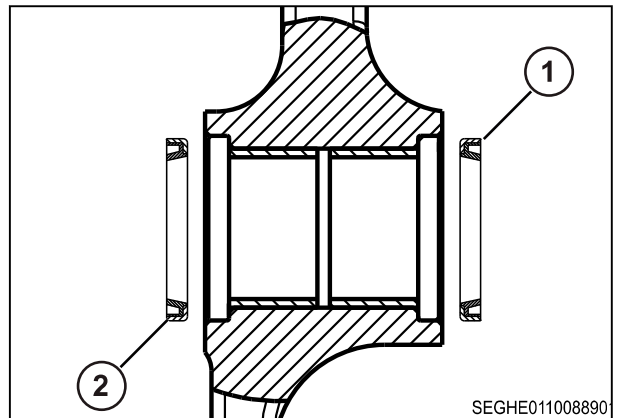

Fig. 23

7. Install the 33 mm (1.3 in) inner spacer (2).

NOTE: The inner spacer inner diameter is larger than the outside spacer inner diameter.

8. Install the gauge wheel arm assembly (1).

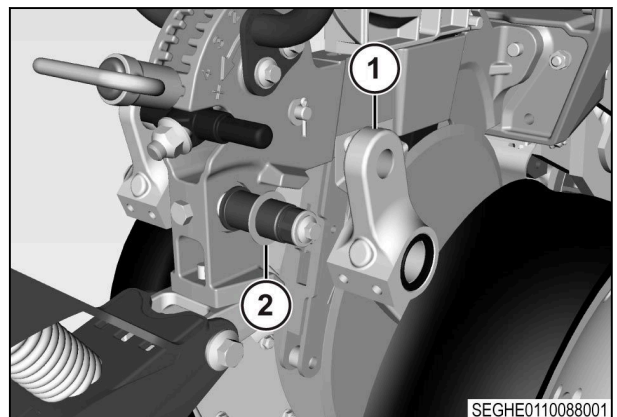

Fig. 24