

G03229471

Fig. 333: Fitting Special Tool 11 2 443 To Special Tool 11 2 446/442 And Secure With Special Tool 11 2 444

Courtesy of BMW OF NORTH AMERICA, INC.

Remove piston for chain tensioner, refer to **11 31 090 INSTALLING AND REMOVING/REPLACING PISTON FOR CHAIN TENSIONER (M62)**

Install special tool 11 3 390 in right timing case cover.

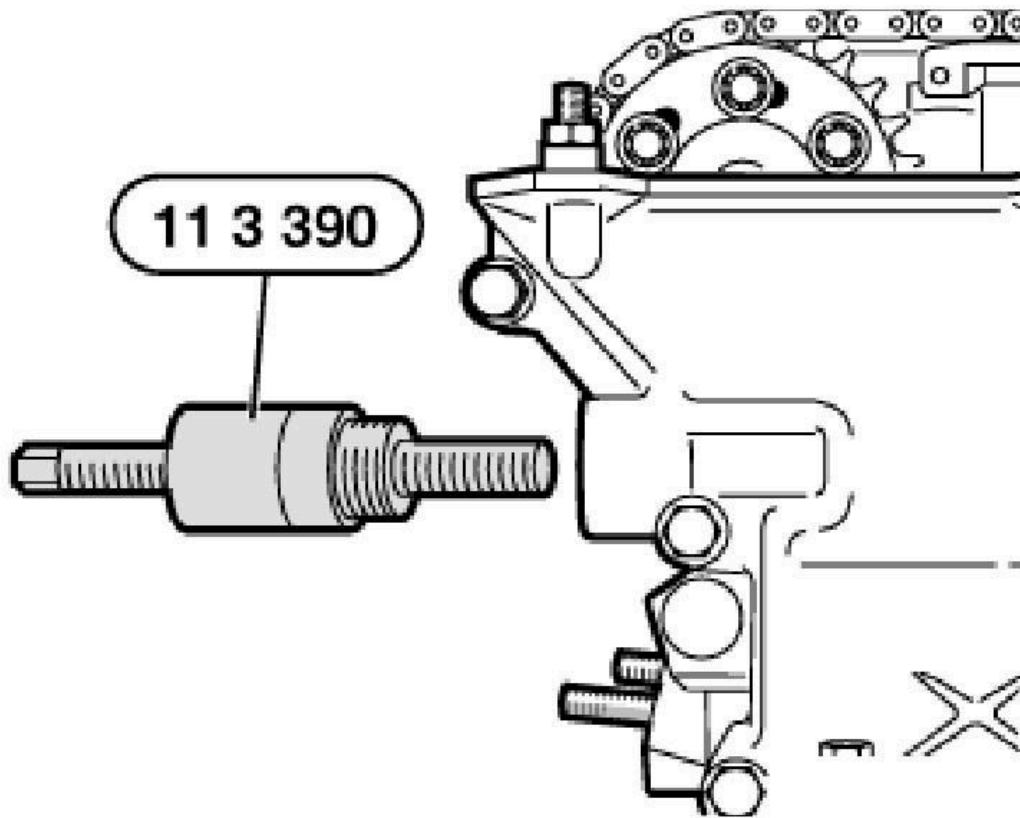

G03229472

Fig. 334: Installing Special Tool 11 3 390 In Right Timing Case Cover
Courtesy of BMW OF NORTH AMERICA, INC.

Tighten bow cover by turning the adjusting screw on the special tool 11 3 390 with special tool 00 9 250 to 0.7 N.m.

NOTE: If installation tolerance is unfavorable, attach special tool 00 9 250 from underside.

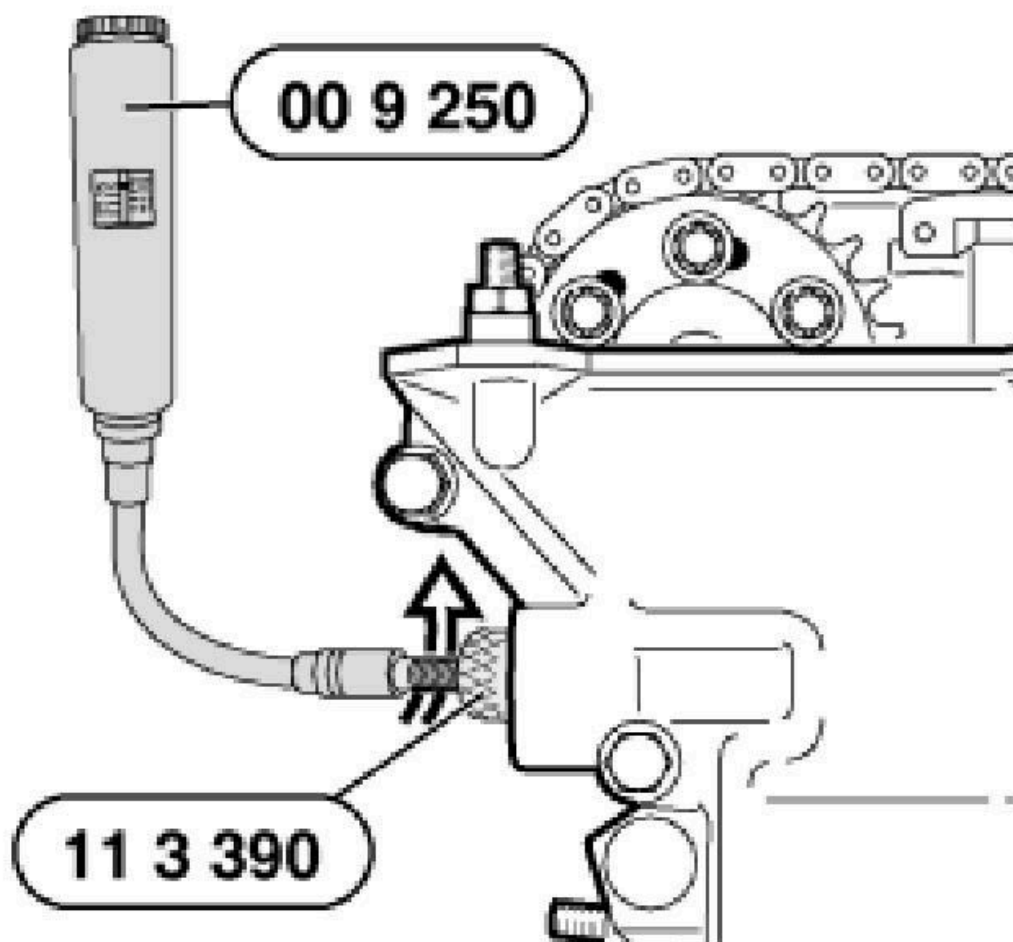

G03229473

Fig. 335: Tightening Bow Cover
Courtesy of BMW OF NORTH AMERICA, INC.

Tighten sprockets in the following order:

Three accessible screws on

1. Exhaust camshaft, left (5 to 8)
2. Exhaust camshaft, right (1 to 4)
3. Inlet camshaft, left (5 to 8)
4. Inlet camshaft, right (1 to 4)

Tightening Torque, refer to 11 31 3AZ CAMSHAFT .

Remove special tool 11 2 300.

Remove special tools from camshafts.

Turn over engine once.

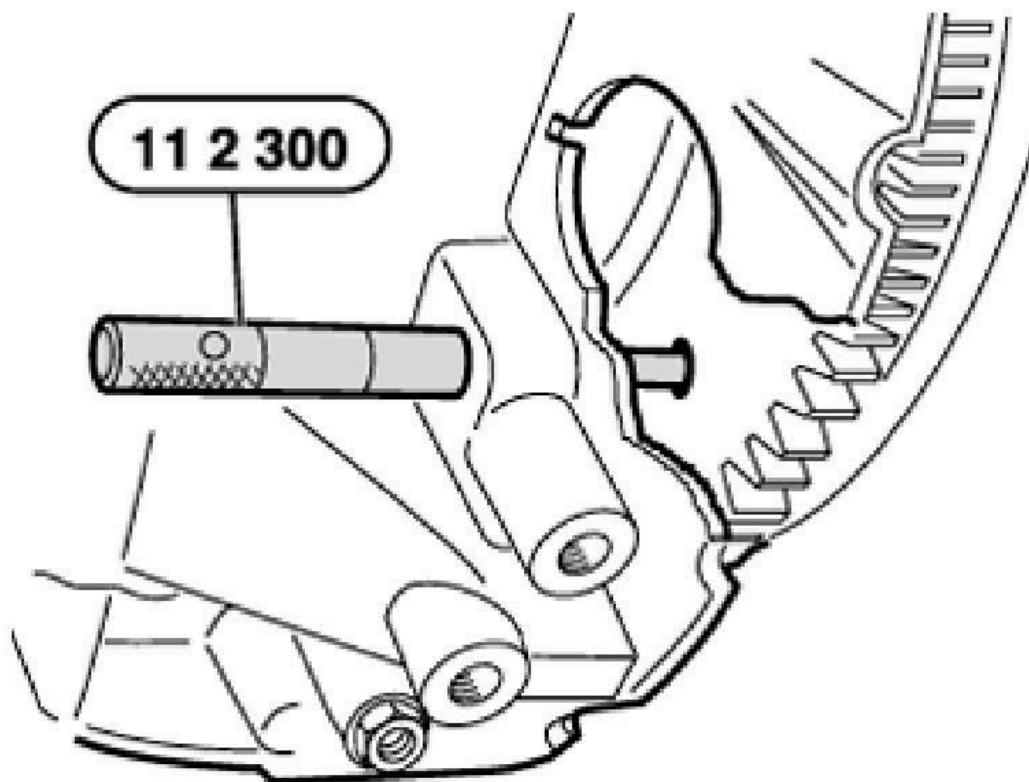

G03229474

Fig. 336: Removing Special Tools 11 2 300 From Camshafts
Courtesy of BMW OF NORTH AMERICA, INC.

Tighten down remaining three screws on exhaust and inlet camshafts on cylinder bank 1 to 4 firmly.

Tightening Torque, refer to 11 31 3AZ CAMSHAFT .

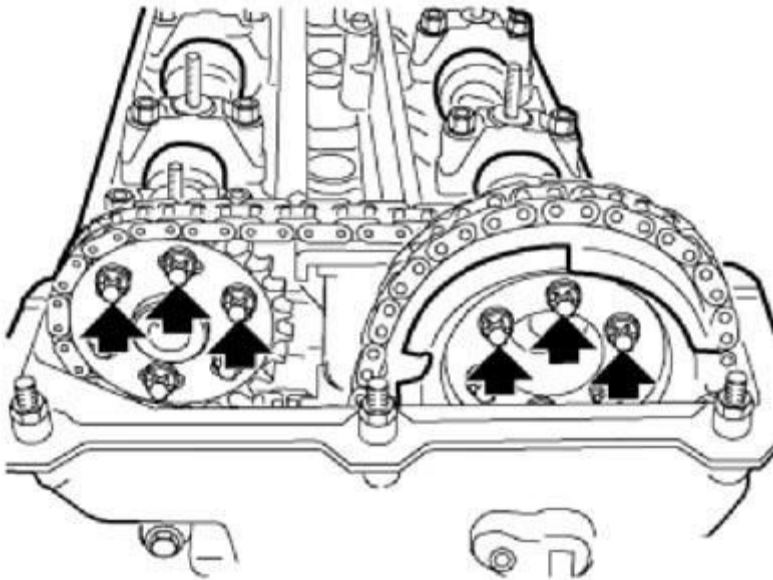

G03229475

Fig. 337: Tightening Exhaust And Inlet Camshafts Screws On Cylinder Bank 1 To 4
Courtesy of BMW OF NORTH AMERICA, INC.

Tighten down remaining three screws on exhaust and inlet camshafts on cylinder bank 5 to 8 firmly.

Tightening Torque, refer to 11 31 3AZCAMSHAFT .

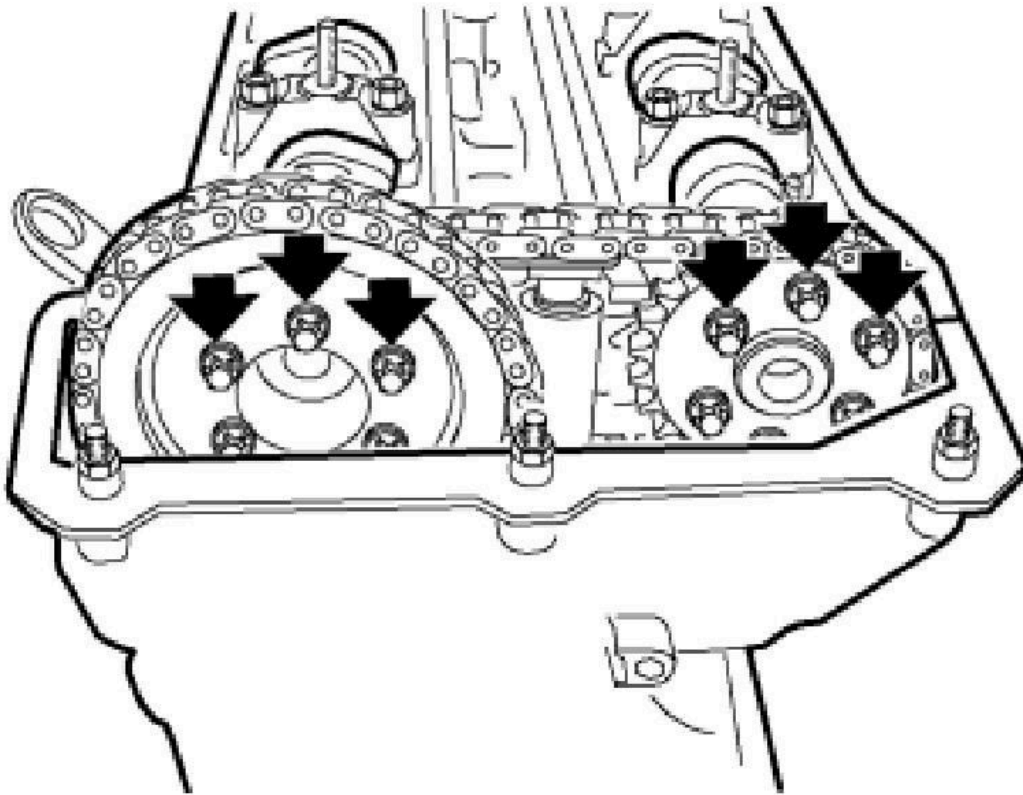

G03229476

Fig. 338: Tightening Exhaust And Inlet Camshafts Screws On Cylinder Bank 5 To 8
Courtesy of BMW OF NORTH AMERICA, INC.

Install all oil lines to left and right cylinder heads.

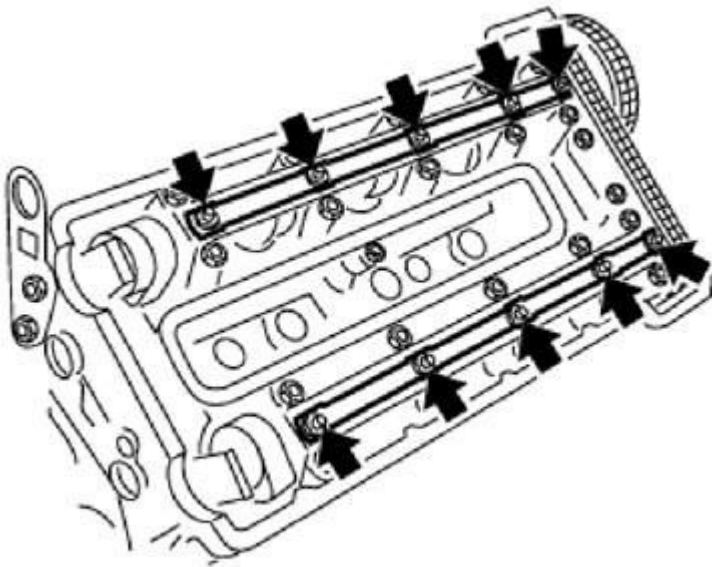

G03229477

Fig. 339: Installing Left And Right Cylinder Heads Oil Lines
Courtesy of BMW OF NORTH AMERICA, INC.

Unfasten and remove special tool 11 3 390.

Assemble engine.

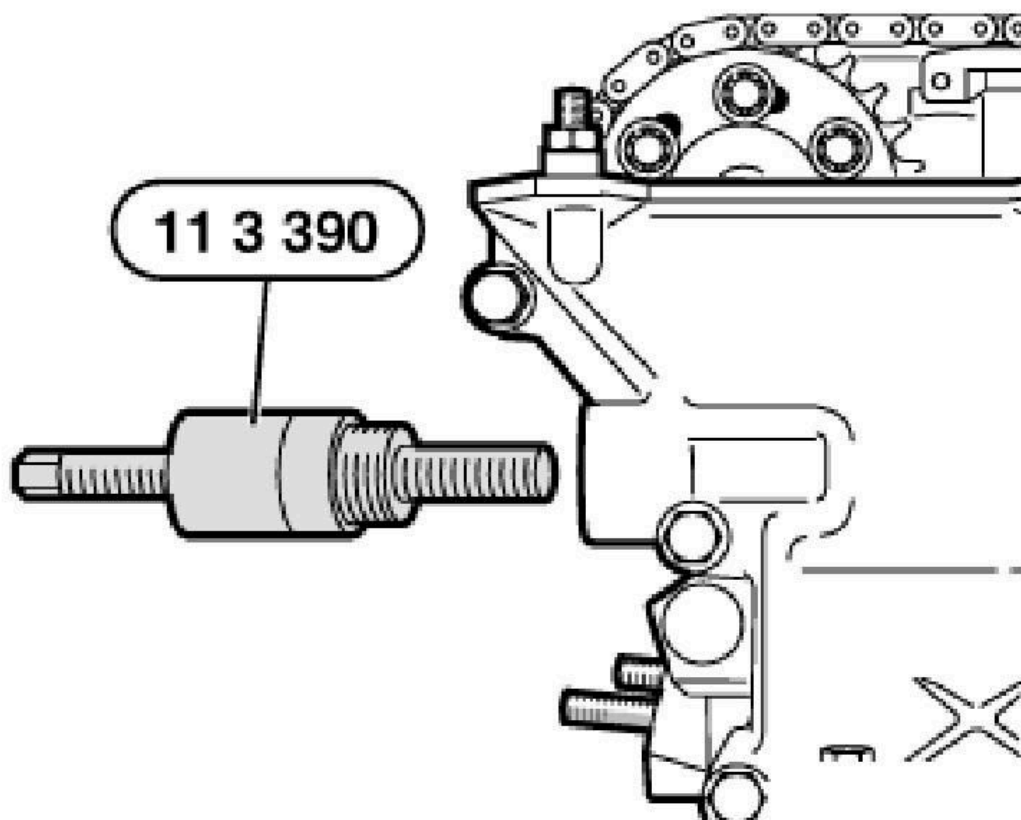

G03229478

Fig. 340: Removing Special Tool 11 3 390
Courtesy of BMW OF NORTH AMERICA, INC.

11 31 011 REPLACING LEFT CAMSHAFT (M62 UP TO 9/98)

(Intake or exhaust side as applicable)

Cylinder bank 5 to 8

Unscrew and remove splash guard.

Remove both cylinder heads, refer to **11 12 004 REMOVING AND INSTALLING/SEALING BOTH CYLINDER HEAD COVERS (M62)**.

Remove all spark plugs, refer to **12 12 011 REPLACING ALL SPARK PLUGS (M60, M62)** .

Removal

The removal of the camshaft is described separately from the installation. Assembly sequence for removal and installation is different.

Remove all oil lines to left and right cylinder head.

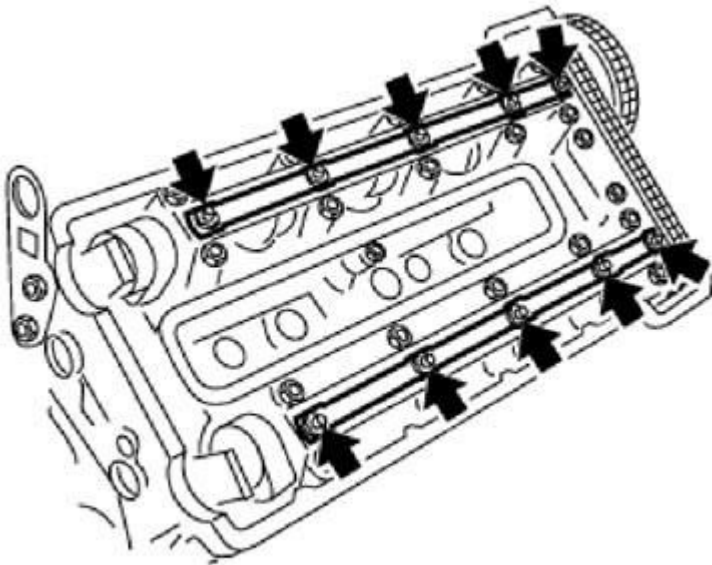

G03229479

Fig. 341: Removing Left And Right Cylinder Heads Oil Lines
Courtesy of BMW OF NORTH AMERICA, INC.

Crank engine at central bolt in direction of rotation until the first cylinder is in TDC position.

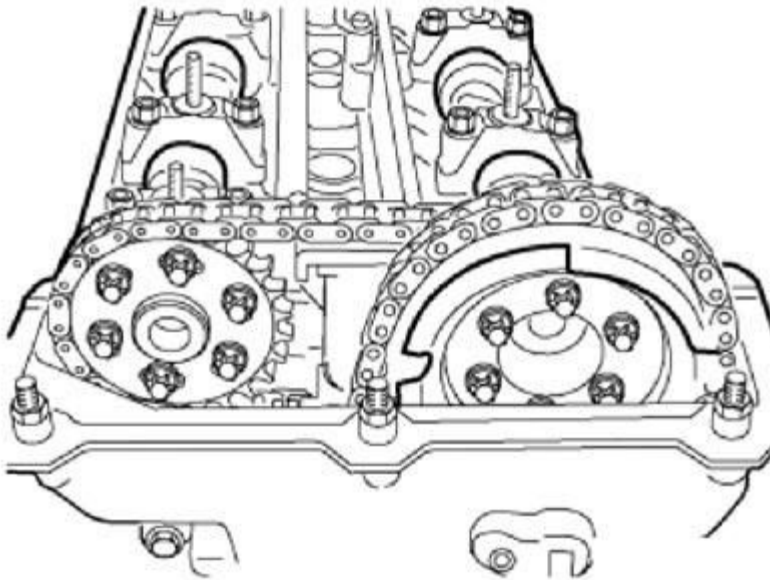

G03229480

Fig. 342: Identifying Central Bolt Position
Courtesy of BMW OF NORTH AMERICA, INC.

Unfasten the accessible three screws on exhaust and inlet camshafts on cylinder bank 1 to 4 approx. 1/2 a turn.