

External Service Brake Inspection

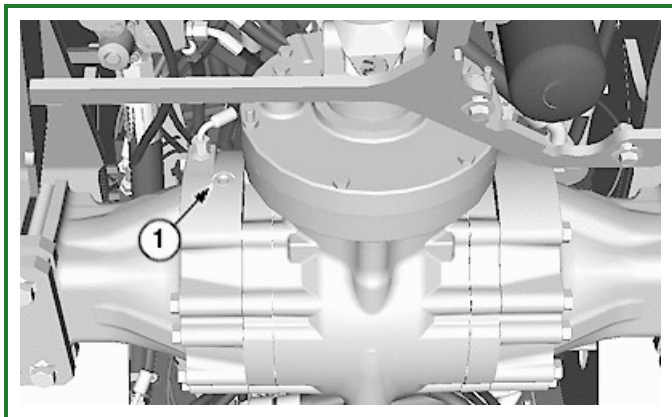

TX1106351-UN: Front Side of Rear Axle Shown

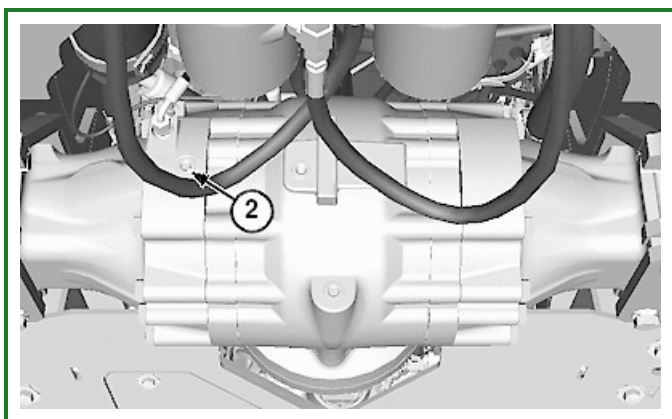

TX1106354-UN: Back Side of Rear Axle Shown

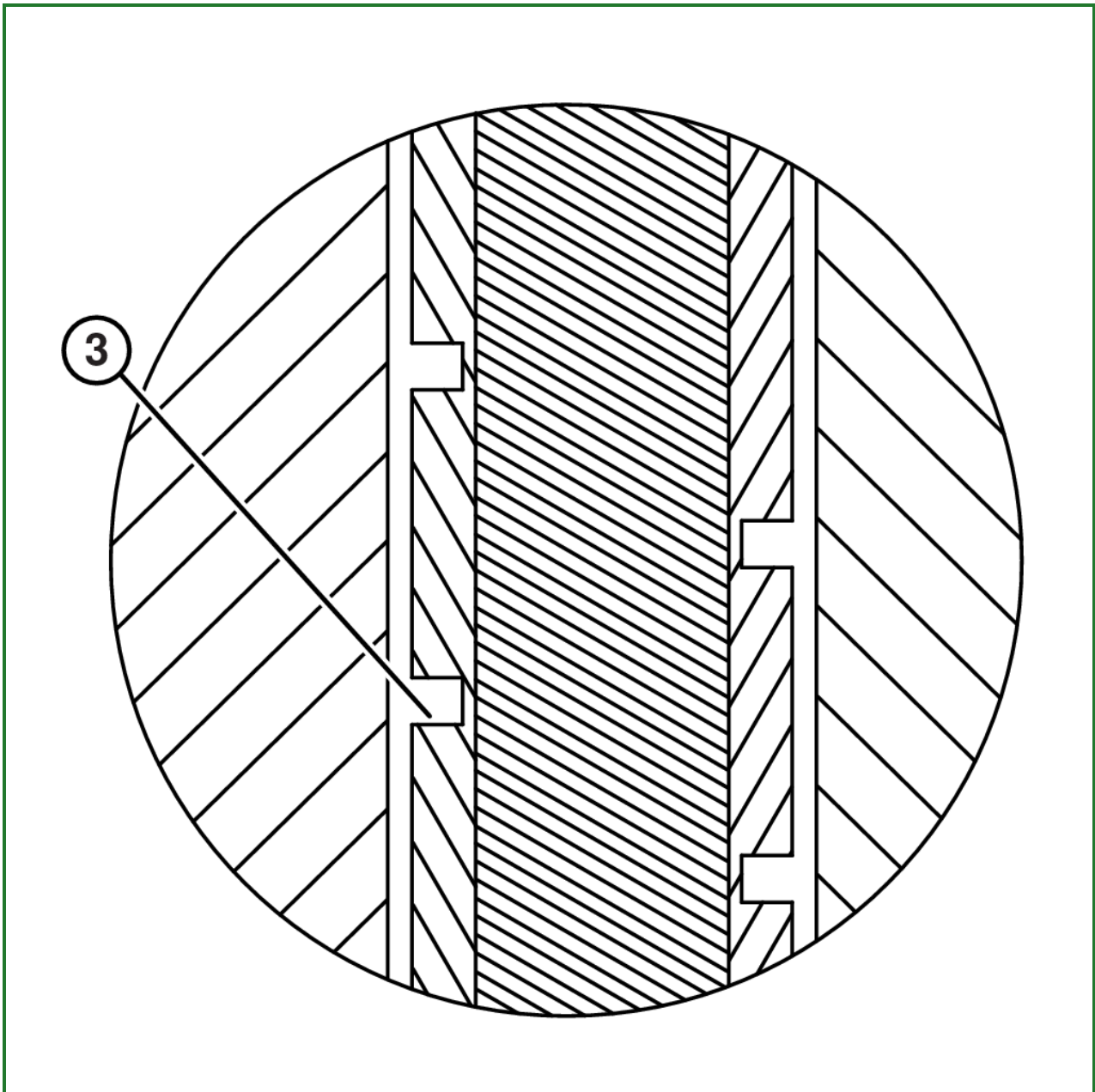
**TX1002476A-UN: Oil Groove****LEGEND:**

- 1 - Right Rear Wheel External Inspection Port
- 2 - Left Rear Wheel External Inspection Port
- 3 - Oil Groove

Do first inspection at 2000 hours followed by 1000 hour inspection intervals after the first 2000 hour inspection.

If the service brakes are subjected to severe duty, inspect more frequently.

1. Inspect brakes for wear through the right and left rear wheel external inspection ports (1 and 2).
2. Remove axle housing and replace brake disc if oil grooves (3) on facing material are no longer visible.

LB82152,0000B29-19-20120227