

Illustration 21 g00529729
(12) Electronic injector code

NOTICE

When a fuel injector group is serviced, the new fuel injector group's electronic injector code must be programmed into the engine's personality module software by using the calibration menu on the Electronic Service Tool. If the new fuel injector group's electronic code is not entered, the previous fuel injector group's characteristics are assumed.

If it is not possible to immediately reprogram the electronic injector code of the injector into the personality module software, the engine will not be severely harmed. The new electronic injector code should be reprogrammed as quickly as possible in order to optimize engine performance.

4. Position the unit injector (3) in the cylinder head assembly. Place the hold down clamp (10) at the base of the unit injector. Push down on the return spring of the unit injector in order to seat the unit injector.
5. Install spacer assembly (9) and bolt (8) that holds the unit injector in place.
6. Pull the unit injector completely into the bore. Tighten the bolt to a torque of 30 N·m (22 lb ft).
7. Install cap assembly (5). Tighten nuts (6) to a torque of 2.5 ± 0.25 N·m (22 ± 2 lb in).
8. Install bridge assemblies (7) onto the valve stems.

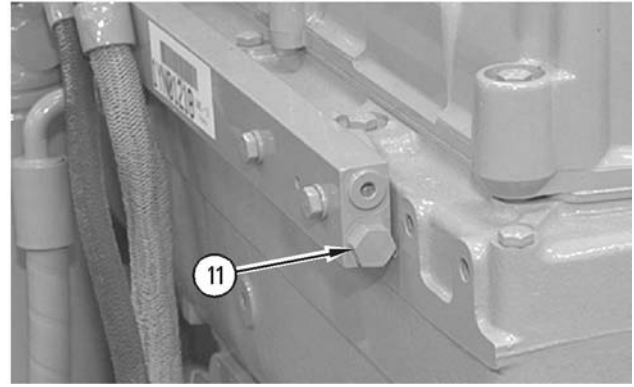

Illustration 22 g00511936

9. Install plug (11) in the fuel manifold.

End By:

- a. Install the rocker shaft and the pushrods. Refer to Disassembly and Assembly, "Rocker Shaft and Pushrod - Install".

i01770685

Electronic Unit Injector Sleeve - Remove

SMCS Code: 1713-011

Removal Procedure

Table 5

Required Tools			
Tool	Part Number	Part Description	Qty
A ⁽¹⁾	221 - 9778	Puller Stud	1
	128 - 7889	Bridge Puller	1
	9U - 6877	Thrust Bearing	1
	5P - 8247	Hard Washer	1
	4K - 0367	Nut	1

⁽¹⁾ The tools that are listed in the chart are part of the 9U - 6891 Injector Tool Group.

Start By:

- a. Remove the electronic unit injectors. Refer to Disassembly and Assembly, "Electronic Unit Injector - Remove".

i01770693

NOTICE

Keep all parts clean from contaminants.

Contaminants may cause rapid wear and shortened component life.

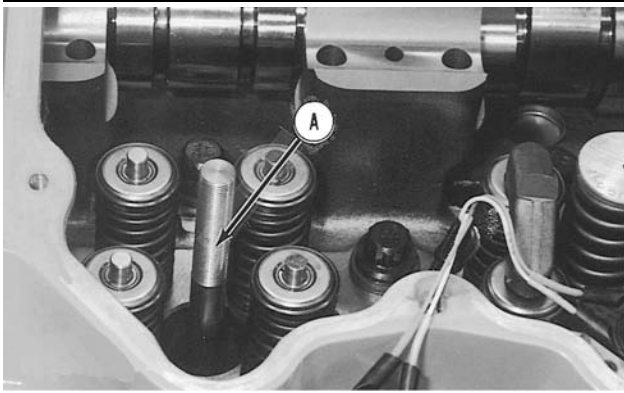

Illustration 23
Typical example
g00512128

1. Install the puller stud from Tooling (A) into the unit injector sleeve.

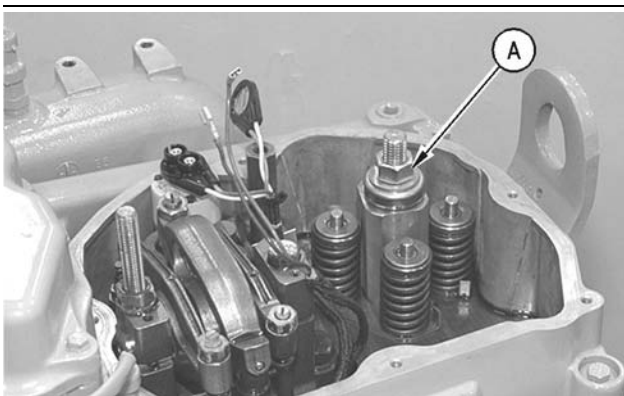

Illustration 24
g00512002

2. Install the following parts from Tooling (A) over the stud: bridge puller, thrust bearing, hard washer, and nut. See Step 1.
3. Tighten the nut until the unit injector sleeve is pulled free of the cylinder head assembly.
4. Remove Tooling (A) from the unit injector sleeve.
5. Repeat Steps 1 through 4 in order to remove the remaining unit injector sleeves.

Electronic Unit Injector Sleeve - Install

SMCS Code: 1713-012

Installation Procedure

Table 6

Required Tools			
Tool	Part Number	Part Description	Qty
A	4C-5552	Large Bore Brush	1
B	9U-7237	Brush Extension	1
	9U-7244	End Brush	1
C	9U-7258	Driver Cap	1

NOTICE

Keep all parts clean from contaminants.

Contaminants may cause rapid wear and shortened component life.

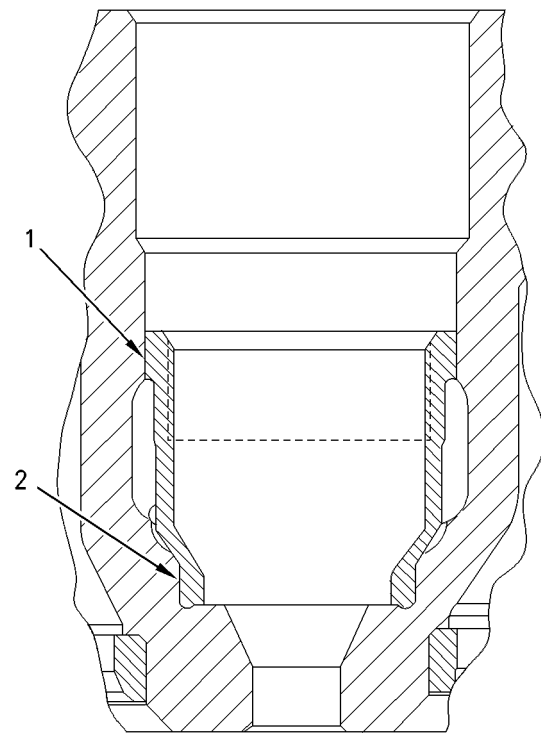

Illustration 25

g00512115

1. Use Tooling (A) to clean the unit injector bore.
2. Use Tooling (B) to clean the unit injector seat.

Note: Check the fuel passage in the cylinder head assembly. Remove any debris left from the use of Tooling (A) and Tooling (B).

3. Apply **4C-9507** Retaining Compound to upper land (1) and lower land (2) on the unit injector sleeve.

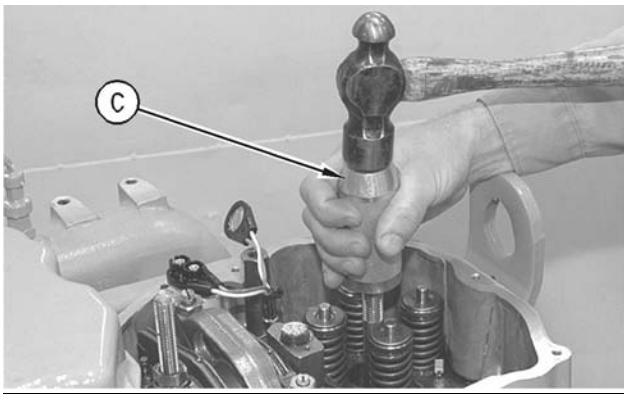

Illustration 26

g00512116

4. Position the unit injector sleeve in the cylinder head assembly. Use Tooling (C) and a hammer to seat the sleeve.
5. Repeat Step 1 through Step 4 in order to install the remaining unit injector sleeves.

End By:

- a. Install the electronic unit injectors. Refer to Disassembly and Assembly, "Electronic Unit Injector - Install".

i01781769

Turbocharger - Remove

SMCS Code: 1052-011

Removal Procedure

NOTICE

Care must be taken to ensure that fluids are contained during performance of inspection, maintenance, testing, adjusting and repair of the product. Be prepared to collect the fluid with suitable containers before opening any compartment or disassembling any component containing fluids.

Refer to Special Publication, NENG2500, "Caterpillar Tools and Shop Products Guide" for tools and supplies suitable to collect and contain fluids on Caterpillar products.

Dispose of all fluids according to local regulations and mandates.

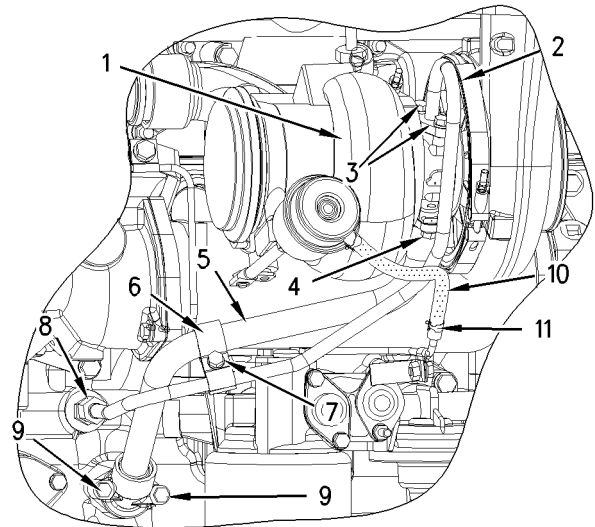

Illustration 27

g00911767

1. Remove bolts (3).
2. Remove bolt (7) with the nut and the washer. Remove saddle clamp (6).
3. Remove bolts (9) and the washers.
4. Disconnect fitting (8).
5. Remove oil supply tube (2) and the gasket.
6. Remove bolts (4) and the washers.
7. Remove oil drain tube (5). Remove the O-ring seal and the gasket from oil drain tube (5).
8. Move hose clamp (11). Disconnect hose (10).

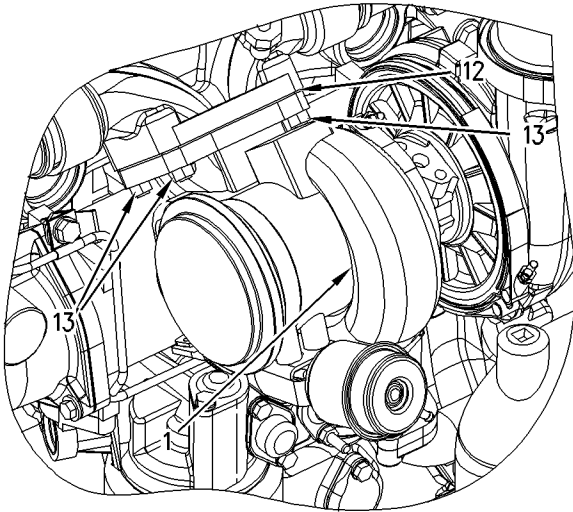

Illustration 28

g00911698

9. Remove four nuts (13).
10. Remove turbocharger (1) and gasket (12) from the exhaust manifold.

i01781774

Turbocharger - Install

SMCS Code: 1052-012

Installation Procedure

Table 7

Required Tools			
Tool	Part Number	Part Description	Qty
(A)	5P-3931	Anti-Seize Compound	1

1. Inspect the condition of the gasket between the turbocharger and the exhaust manifold and the O-ring seals. Replace the O-ring seals and the gaskets, if necessary.

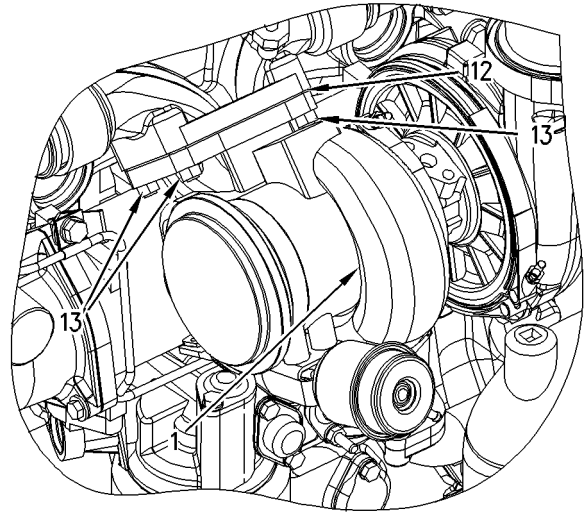

Illustration 29

g00911698

Note: Refer to the Specifications Manual for the tightening procedure of the clamps on specific turbochargers.

2. Place clean engine oil in the oil supply port of the turbocharger prior to installation. The oil will provide lubrication during starting and protection during storage.
3. Apply Tooling (A) to the turbocharger mounting studs on the exhaust manifold.
4. Install turbocharger (1) and gasket (12) on the exhaust manifold. Install nuts (13). Tighten the nuts to a torque of 70 N·m (52 lb ft).

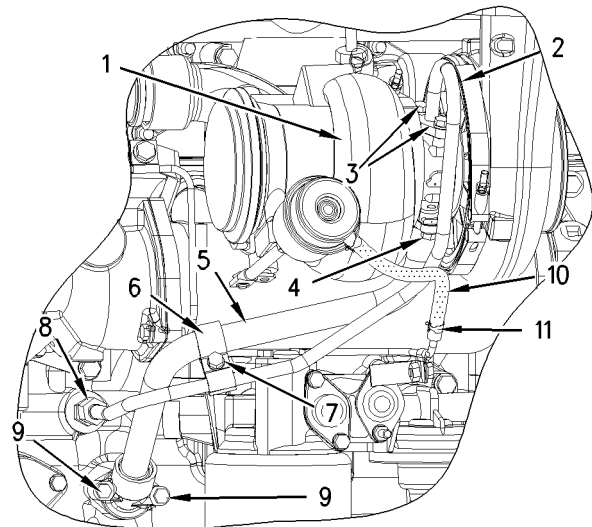

Illustration 30

g00911767

5. Place the gasket and the O-ring seal on oil drain tube (5).
6. Install oil drain tube (5) with two bolts (4) and the washers.
7. Install bolts (9) and the washers.
8. Install oil supply tube (2) and the gasket on turbocharger (1). Install bolts (3) .
9. Connect fitting (8).
10. Install saddle clamp (6) and bolt (7).
11. Install hose assembly (10) onto the tube. Secure the hose assembly with hose clamp (11).

i01781006

Modulating Valve - Remove and Install

SMCS Code: 3139-010

Removal Procedure

Note: Put identification marks on all hose assemblies, on all wires, and on all tube assemblies for installation purposes. Plug all hose assemblies and all tube assemblies. This helps to prevent fluid loss, and this helps to keep contaminants from entering the system.

NOTICE

Care must be taken to ensure that fluids are contained during performance of inspection, maintenance, testing, adjusting and repair of the product. Be prepared to collect the fluid with suitable containers before opening any compartment or disassembling any component containing fluids.

Refer to Special Publication, NENG2500, "Caterpillar Tools and Shop Products Guide" for tools and supplies suitable to collect and contain fluids on Caterpillar products.

Dispose of all fluids according to local regulations and mandates.

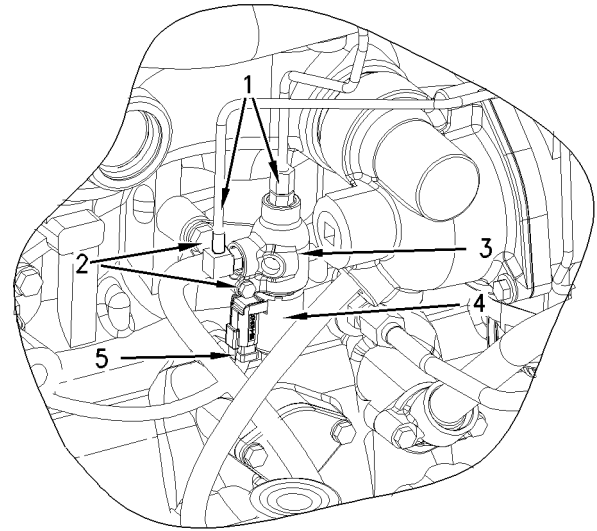

Illustration 31

g00912917

1. Disconnect lines (1) from valve (3).
2. Disconnect wiring harness assembly (5) from solenoid (4).
3. Remove bolts (2). Remove valve (3).
4. Remove solenoid (4) from valve (3).

Installation Procedure

Note: Cleanliness is an important factor. Before assembly, all parts should be thoroughly cleaned in cleaning fluid. Allow the parts to air dry. Wiping cloths or rags should not be used to dry parts. Lint may be deposited on the parts which may cause later trouble. Inspect all parts. If any parts are worn or damaged, use new parts for replacement. All disassembly and all assembly procedures must be performed on a clean work surface and in a clean hydraulic area. Keep cleaned parts covered and protected at all times.

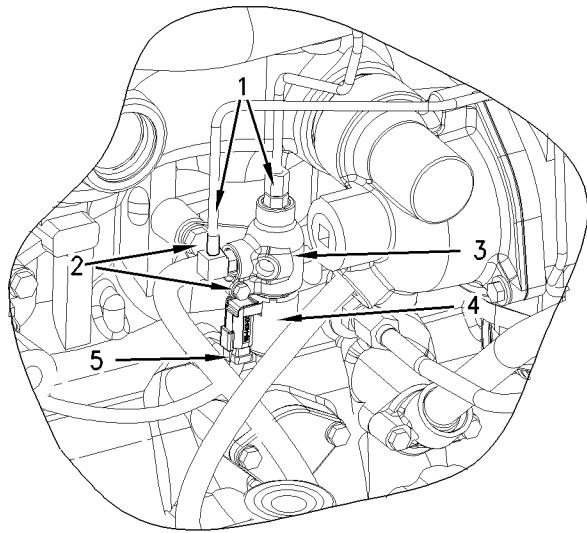

Illustration 32

g00912917

1. Install solenoid (4) onto valve (3). Tighten solenoid (4) to a torque of 50 ± 5 N·m (37 ± 4 lb ft).
2. Install valve (3) in position. Secure valve (3) with bolts (2).
3. Connect wiring harness assembly (5) to solenoid (4).
4. Connect lines (1) onto valve (3).

i01465377

Exhaust Manifold - Remove and Install

SMCS Code: 1059-010

Removal Procedure

Start By:

- a. Remove the turbocharger. Refer to Disassembly and Assembly, "Turbocharger - Remove".

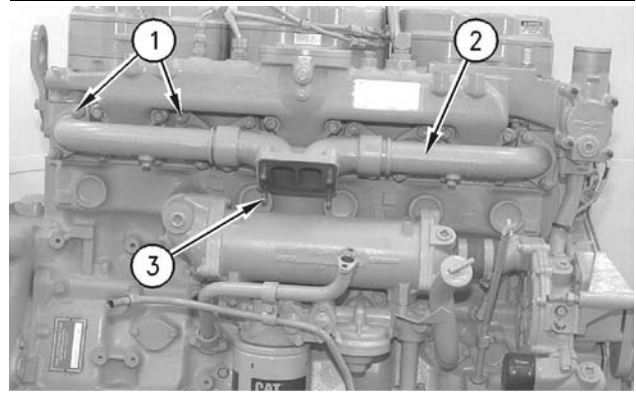

Illustration 33

g00512515

Typical example

1. Remove locknuts (1) with the washers and spacers.
2. Remove exhaust manifold (2) and the gaskets.
3. Remove the studs that hold the exhaust manifold to the cylinder head assembly.
4. Remove studs (3) from the exhaust manifold, if necessary.

Installation Procedure

1. Inspect the condition of the gasket. Replace the gasket, if necessary.
2. Apply **5P-3931** Anti-Seize Compound to the threads of the studs that hold the exhaust manifold to the cylinder head assembly.
3. Install the studs for the cylinder head assembly. Tighten the studs to a torque of 35 ± 5 N·m (26 ± 4 lb ft).

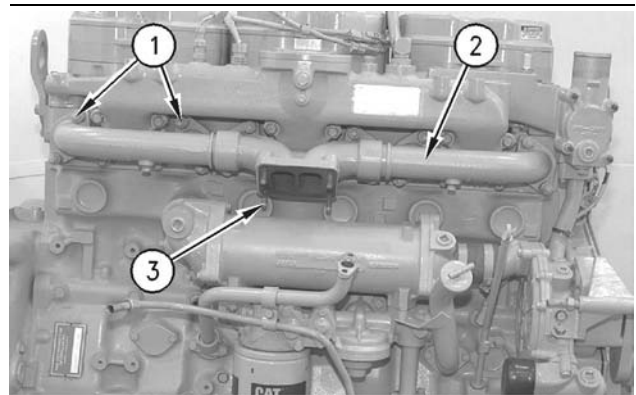

Illustration 34

g00512515

Typical example

4. Position the gaskets with the tabs in the upward position. Install exhaust manifold (2).

5. Apply 5P-3931 Anti-Seize Compound to locknuts (1). Install locknuts (1) with the washers and spacers. Tighten the locknuts to a torque of 55 ± 10 N·m (41 ± 7 lb ft).
6. Apply 5P-3931 Anti-Seize Compound to the threads of studs (3).
7. Install studs (3) in exhaust manifold (2). Tighten the studs to a torque of 35 ± 5 N·m (26 ± 4 lb ft).

End By:

- a. Install the turbocharger. Refer to Disassembly and Assembly, "Turbocharger - Install".

i01337457

Inlet Manifold - Remove**SMCS Code:** 1058-011**Removal Procedure****NOTICE**

Keep all parts clean from contaminants.

Contaminants may cause rapid wear and shortened component life.

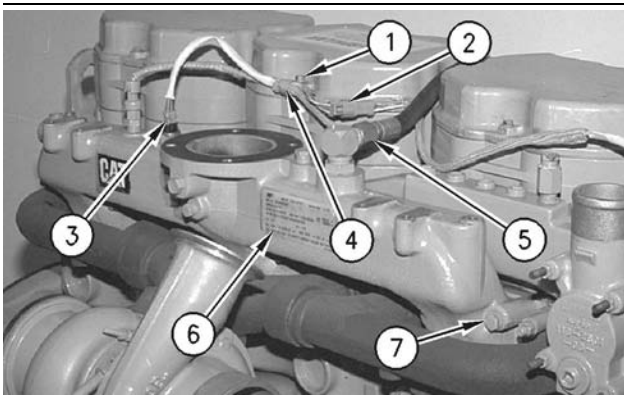

Illustration 35

g00707340

Typical example

1. Disconnect sensor connector (3).
2. Remove bolt (1) and clip (4).
3. Disconnect sensor connector (2).
4. Remove hose assembly (5).
5. Remove bolts (7) and the washers. Remove air inlet manifold (6) and the three gaskets.

i01337547

Inlet Manifold - Install**SMCS Code:** 1058-012**Installation Procedure****NOTICE**

Keep all parts clean from contaminants.

Contaminants may cause rapid wear and shortened component life.

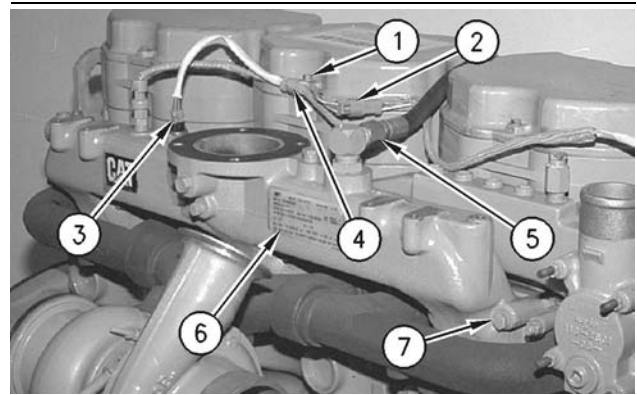

Illustration 36

g00707340

Typical example

1. Inspect the condition of the gaskets. Replace the gaskets, if necessary.
2. Position air inlet manifold (6) and the three gaskets on the cylinder head.
3. Install bolts (7) and the washers. Tighten bolts (7) to a torque of 55 ± 10 N·m (40 ± 7 lb ft).
4. Install hose assembly (5).
5. Connect sensor connector (2).
6. Install clip (4) and bolt (1). Tighten bolt (1) to a torque of 12 ± 3 N·m (9 ± 2 lb ft).
7. Connect sensor connector (3).

i01770734

Inlet and Exhaust Valve Springs - Remove and Install

SMCS Code: 1108-010

Removal Procedure

Table 8

Required Tools			
Tool	Part Number	Part Description	Qty
A	4C-6726	Valve Spring Compressor	1

Start By:

- a. Remove the valve mechanism cover. Refer to Disassembly and Assembly, "Valve Mechanism Cover - Remove and Install".
- b. Remove the electronic unit injector. Refer to Disassembly and Assembly, "Electronic Unit Injector - Remove".

NOTICE

Keep all parts clean from contaminants.

Contaminants may cause rapid wear and shortened component life.

Note: The following procedure is for the removal of the inlet valve springs and the exhaust valve springs without removing the cylinder head. This procedure can be performed on only one cylinder at a time. This will prevent the inlet valves and the exhaust valves from falling into the cylinder.

1. Rotate the crankshaft in order to bring the piston to the top center position in the cylinder.

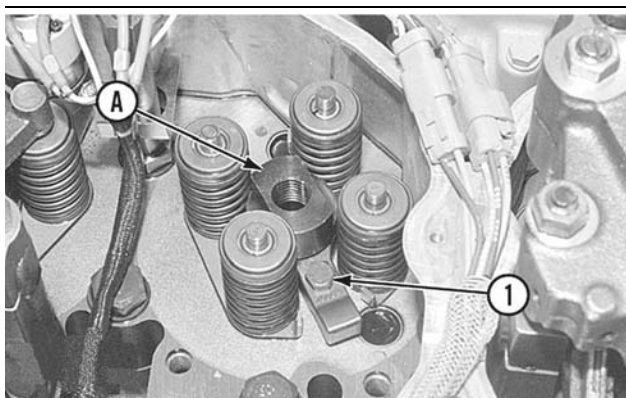

Illustration 37

g00526801

2. Place the bottom portion of Tooling (A) on the cylinder head. Install the hold down bolt (1) .

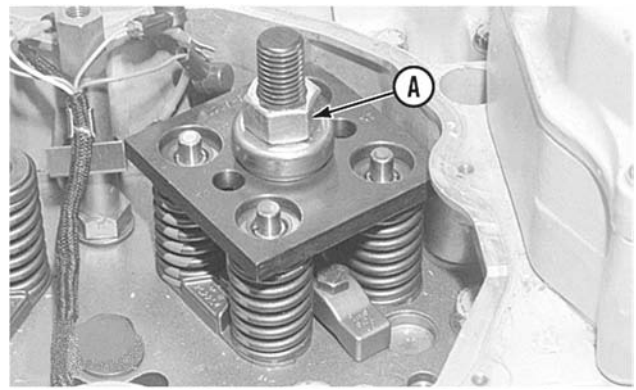

Illustration 38

g00526802

3. Install the remainder of Tooling (A).

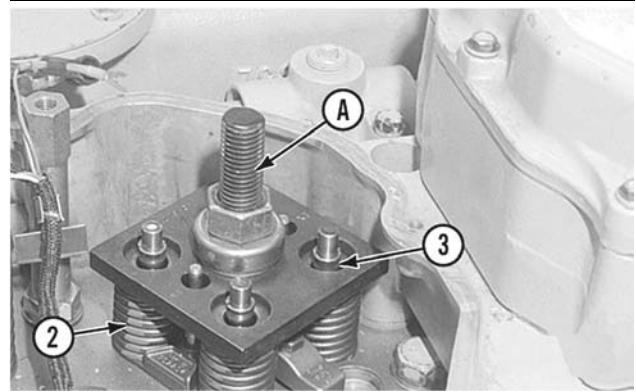

Illustration 39

g00526803

WARNING

Personal injury can result from being struck by parts propelled by a released spring force.

Make sure to wear all necessary protective equipment.

Follow the recommended procedure and use all recommended tooling to release the spring force.

4. Tighten the nut on Tooling (A) in order to compress the inlet valve springs and the exhaust valve springs (2).
5. Remove retainer locks (3).
6. Remove Tooling (A).