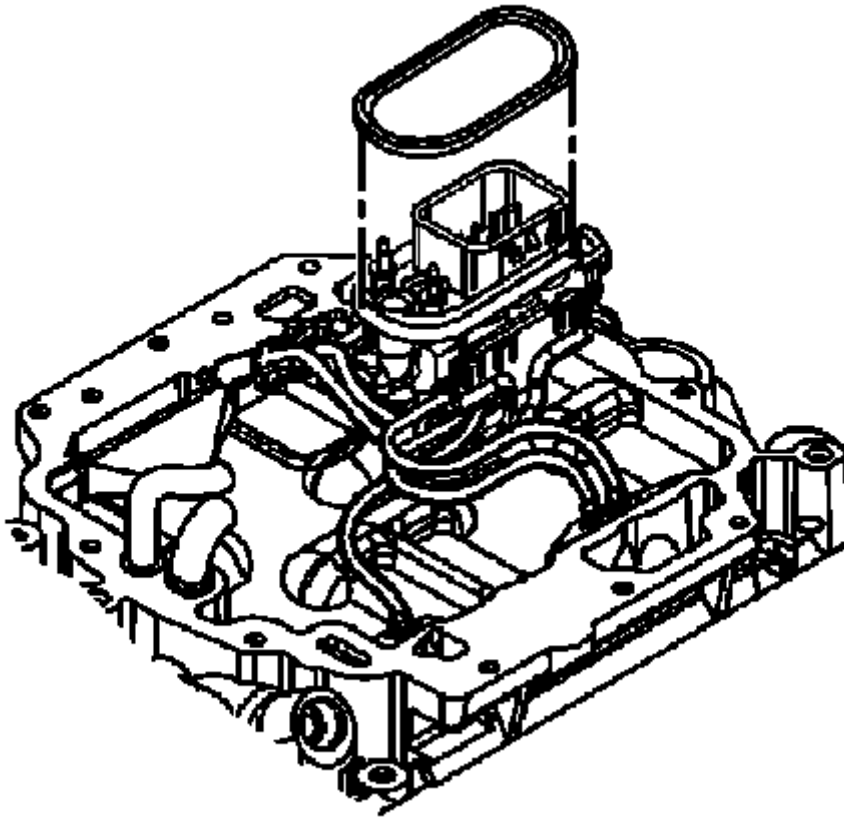

**Fig. 63: View Of Upper Intake Manifold Assembly**  
**Courtesy of GENERAL MOTORS CORP.**

- C. Install the PCV valve cover in the upper intake manifold.
- D. Turn and lock the PCV valve cover in position.
- 4. Install the power brake booster vacuum tube fitting, if removed, using the following procedure:
  - A. Install a NEW seal (O-ring) on the power brake booster vacuum tube

fitting.

- B. Lubricate the seal with clean engine oil.
- C. Install the power brake booster vacuum tube fitting in the upper intake manifold.
- D. Turn and lock the power brake booster vacuum tube fitting in position.



**Fig. 64: Locating Seal For Fuel Meter Body Assembly**  
Courtesy of GENERAL MOTORS CORP.

- 5. Install a NEW seal on the fuel meter body assembly.
- 6. Lubricate the seal with clean engine oil.

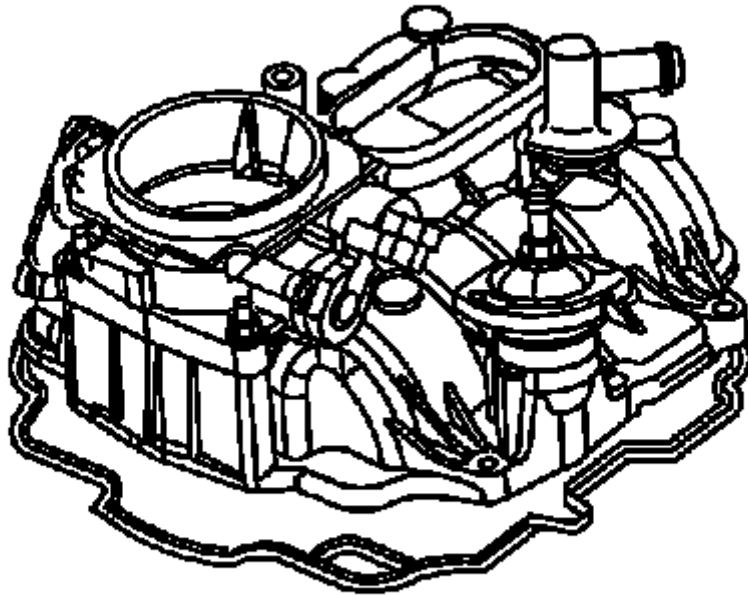

**Fig. 65: View Of Upper Intake Manifold**  
**Courtesy of GENERAL MOTORS CORP.**

7. Install a NEW upper intake manifold to lower intake manifold gasket in the groove of the upper intake manifold.

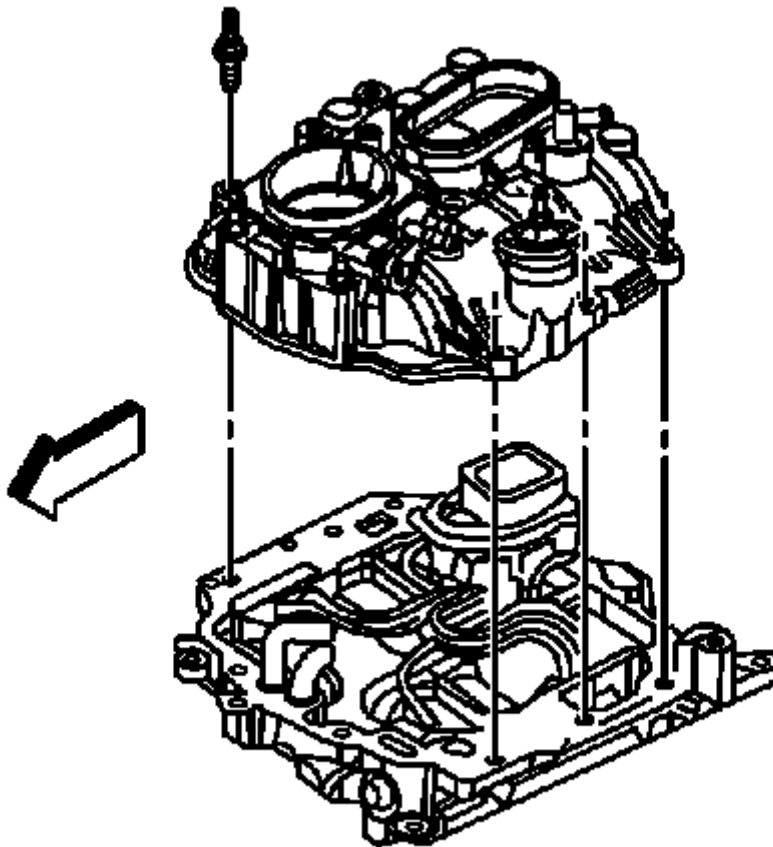

**Fig. 66: Locating Upper Intake Manifold Studs**  
Courtesy of GENERAL MOTORS CORP.

8. Install the upper intake manifold onto the lower intake manifold.
9. If reusing the fasteners, apply threadlock GM P/N 12345382 or equivalent to the threads of the upper intake manifold attaching bolts.

**NOTE: Refer to Fastener Notice in Cautions and Notices.**

10. Install the upper intake manifold attaching studs.

**Tighten:**

- A. Tighten the upper intake manifold attaching studs on the first pass to 5 N.m (44 lb in).
  - B. Tighten the upper intake manifold attaching studs on the final pass to 9 N.m (80 lb in).
11. Install the fuel lines to the fuel meter body assembly. Refer to **Fuel Hose/Pipes Replacement - Engine Compartment** in Engine Controls -

--	--

4.3L.

12. Install the EVAP canister purge solenoid valve. Refer to **Evaporative Emission (EVAP) Canister Purge Solenoid Valve Replacement** in Engine Controls - 4.3L.

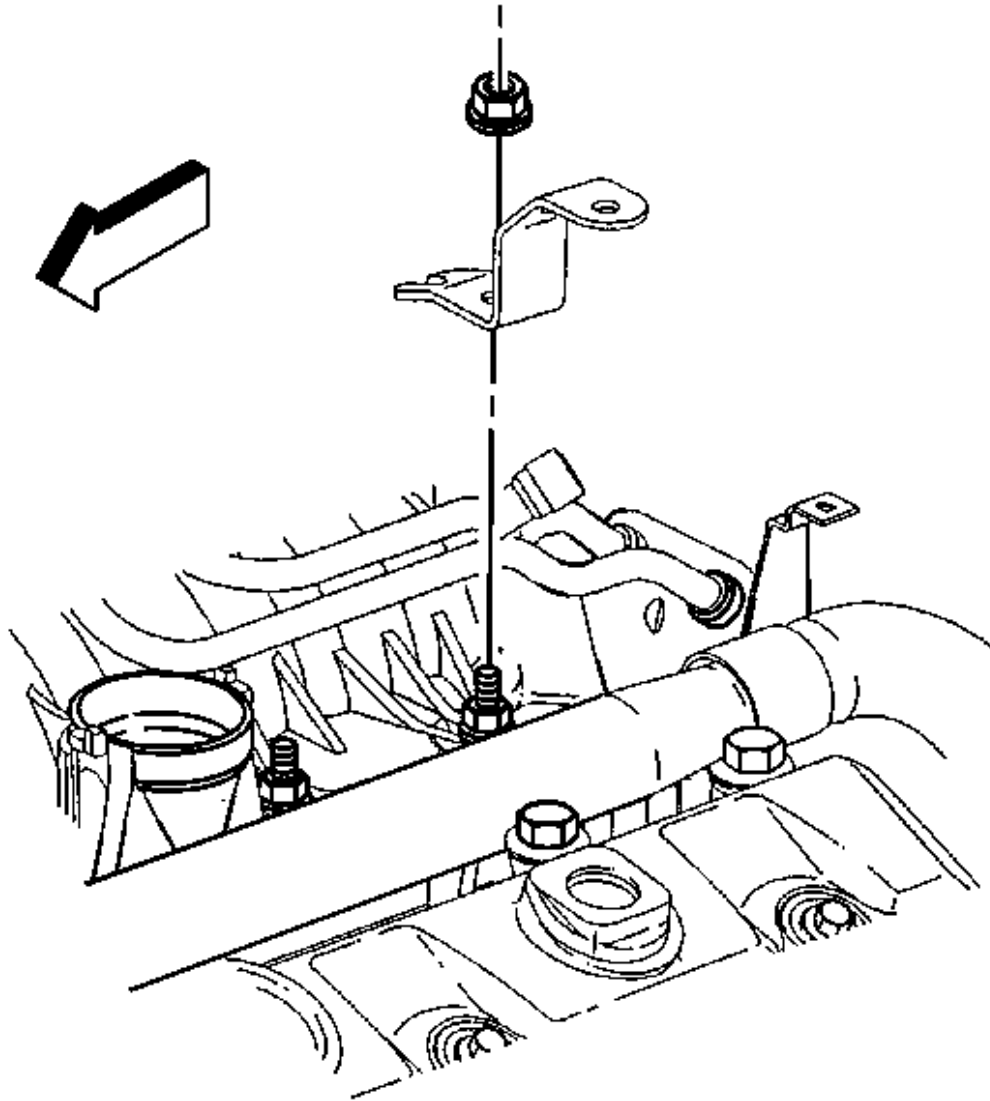

**Fig. 67: View Of Bracket For Engine Wiring Harness**  
**Courtesy of GENERAL MOTORS CORP.**

13. Install the bracket for the engine wiring harness on the lower intake

manifold stud.

14. Install the engine wiring harness bracket nut.

**Tighten:** Tighten the engine wiring harness bracket nut to 12 N.m (106 lb in).

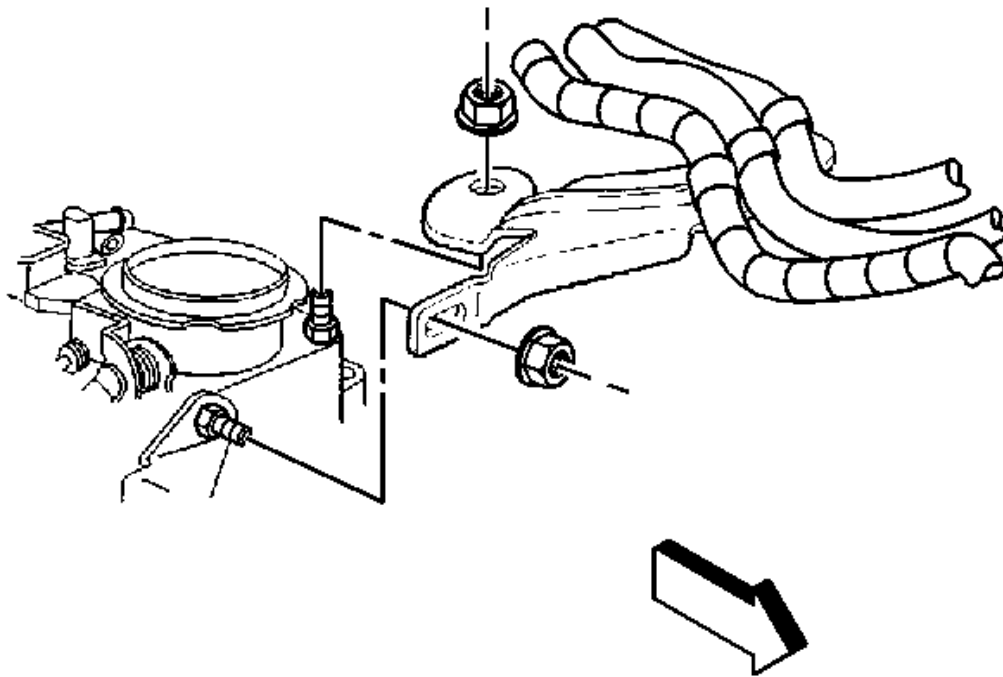

**Fig. 68: View Of Accelerator & Cruise Control Cable Bracket**  
**Courtesy of GENERAL MOTORS CORP.**

15. Install the accelerator and cruise control cable bracket to the throttle body.
16. Install the accelerator and cruise control cable bracket nuts.

**Tighten:** Tighten the accelerator and cruise control cable bracket nuts to 9 N.m (80 lb in).

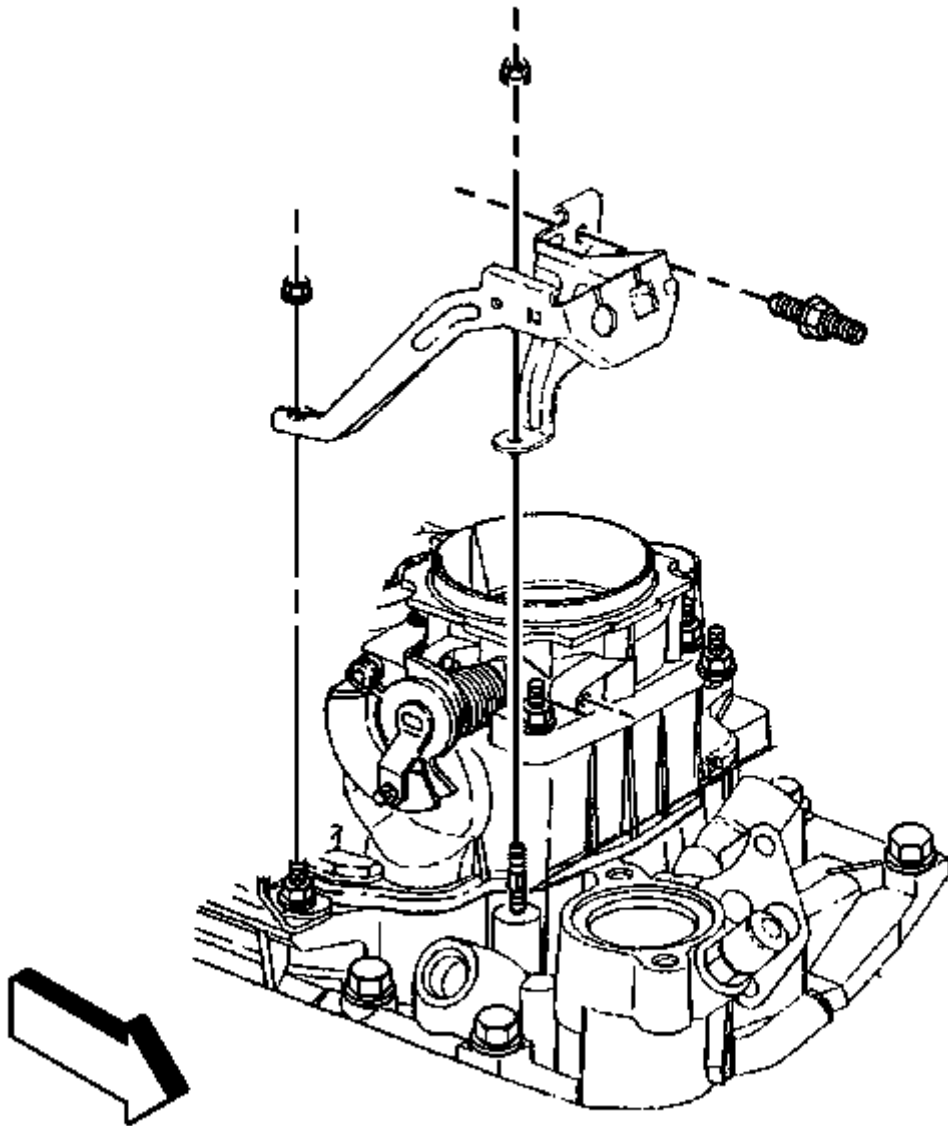

**Fig. 69: View Of Accelerator Cable Bracket**  
Courtesy of GENERAL MOTORS CORP.

17. Install the accelerator control cable bracket to the throttle body and the intake manifold.

**Tighten:** Tighten the accelerator control cable bracket studs and nuts to 12 N.m (106 lb in).

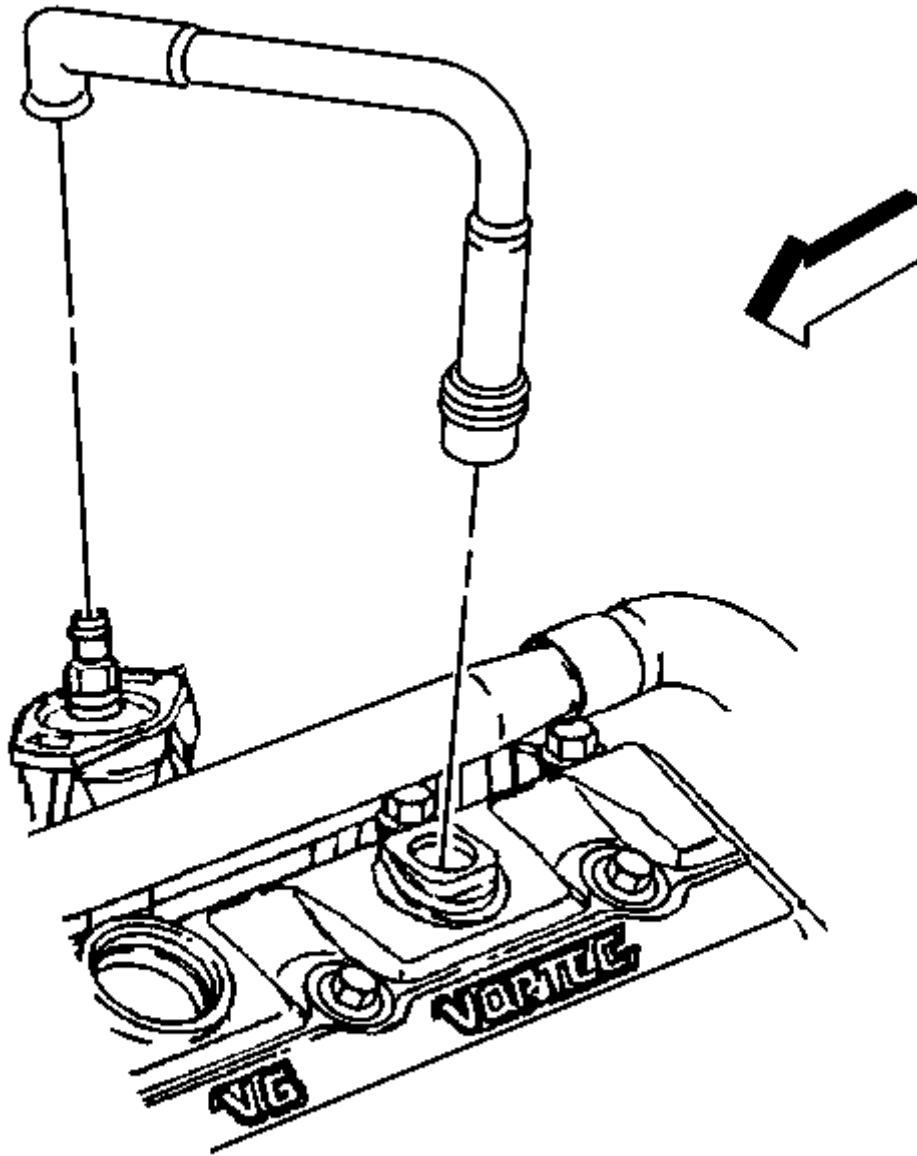

**Fig. 70: Identifying Breather Tube**  
Courtesy of GENERAL MOTORS CORP.

18. Connect the PCV valve hose assembly to the intake manifold and the valve rocker arm cover.



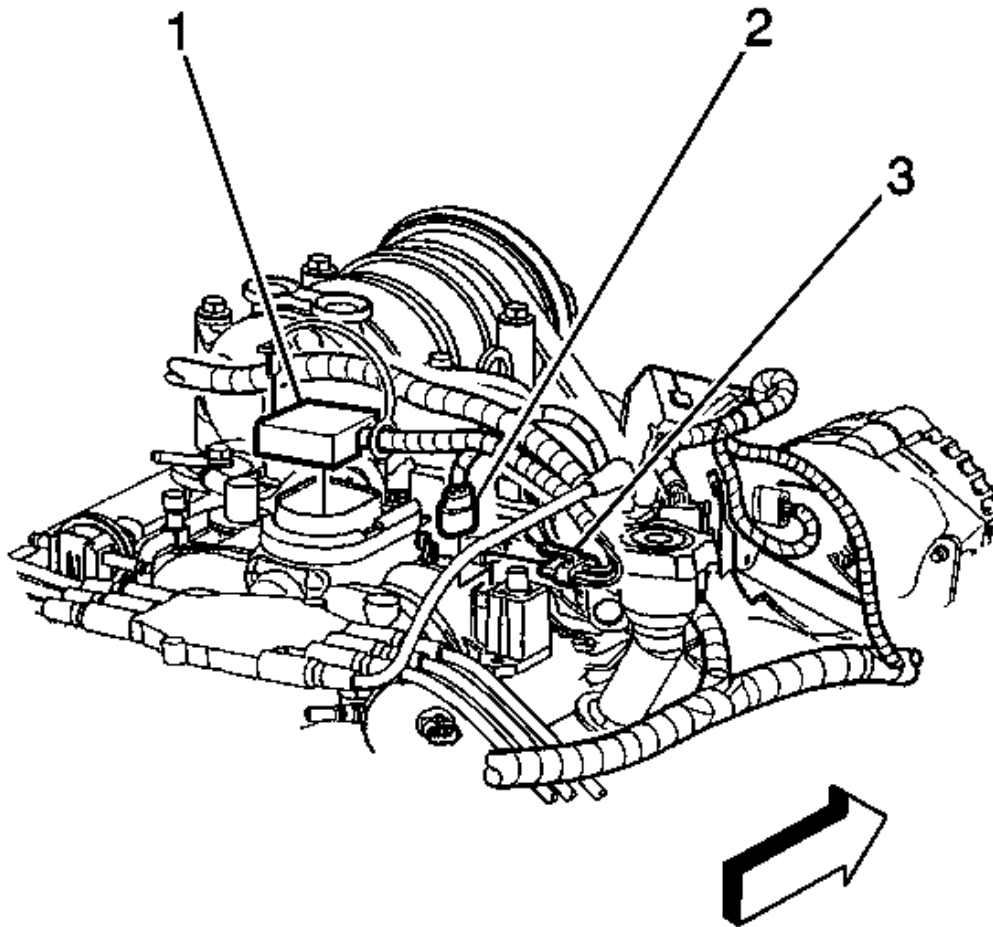

**Fig. 71: Locating Electrical Connectors**  
**Courtesy of GENERAL MOTORS CORP.**

19. Position the engine wiring harness.
20. Install the wire harness clip to the accelerator cable bracket.
21. Connect the following electrical connectors:
  - The fuel meter body assembly (1)
  - The manifold absolute pressure (MAP) sensor (3)
  - The EVAP canister purge solenoid valve (2)

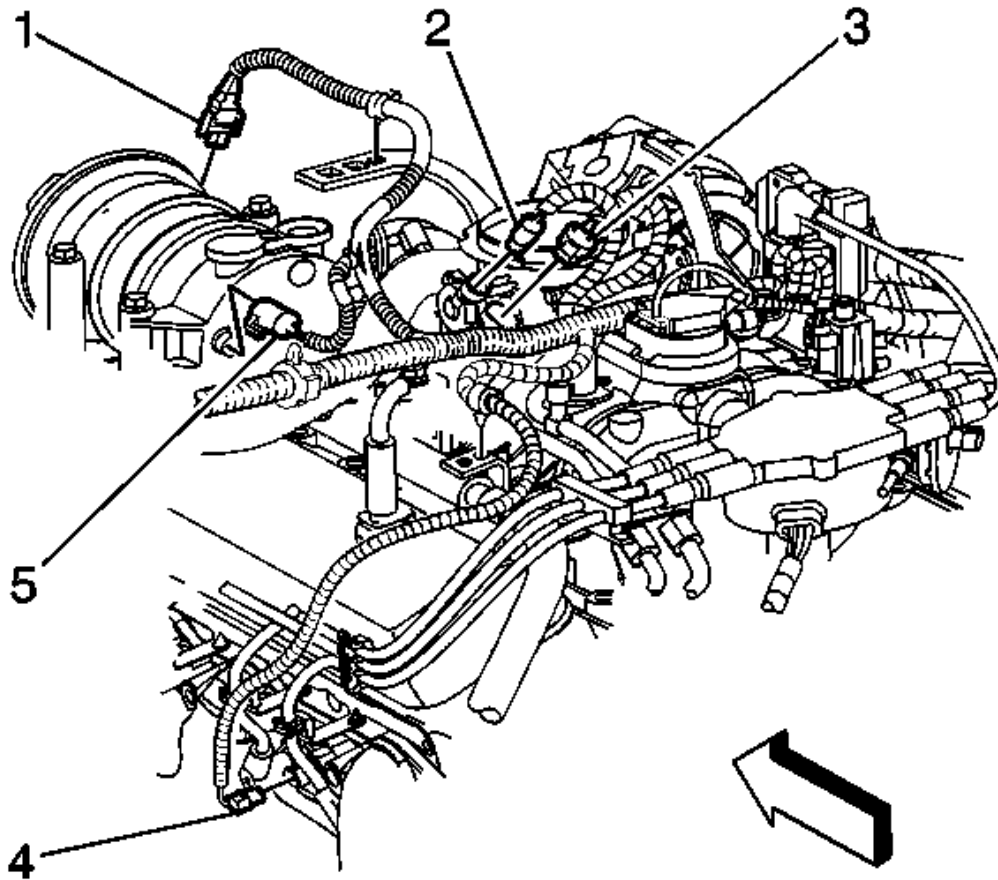

**Fig. 72: Locating Electrical Connectors**  
**Courtesy of GENERAL MOTORS CORP.**

22. Connect the following electrical connectors:

- The A/C compressor clutch (1)
- The A/C compressor cutoff switch (5), if equipped
- The throttle position (TP) sensor (2)
- The idle air control (IAC) motor (3)

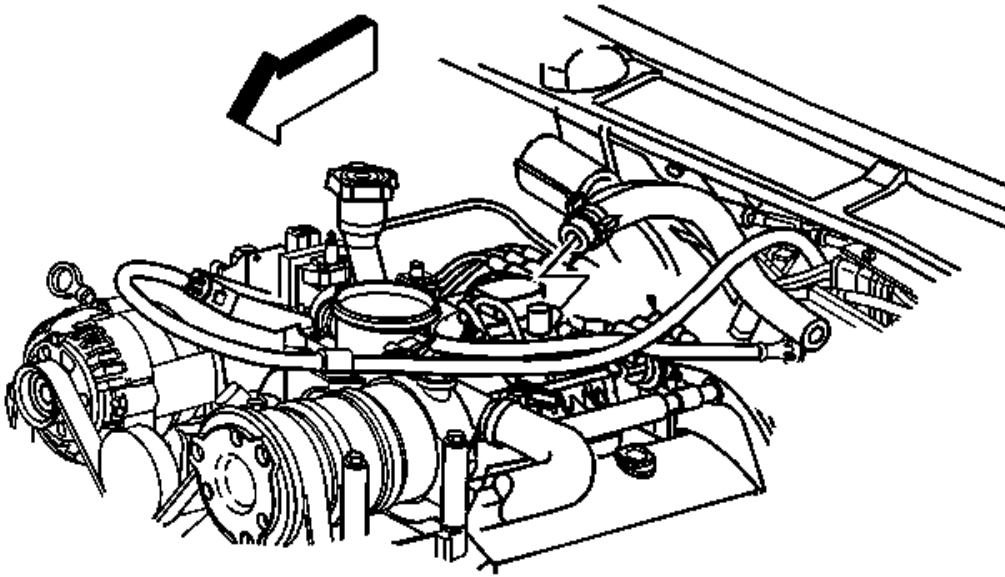

**Fig. 73: View Of Vacuum Brake Booster Hose**  
**Courtesy of GENERAL MOTORS CORP.**

23. Connect the vacuum hose from the vacuum tank to the intake manifold.
24. Install the power brake booster vacuum hose to the intake manifold.
25. Install the cruise control cable, if equipped to the throttle shaft and the bracket. Refer to **Cruise Control Cable Replacement (4.3L)** in Cruise Control.

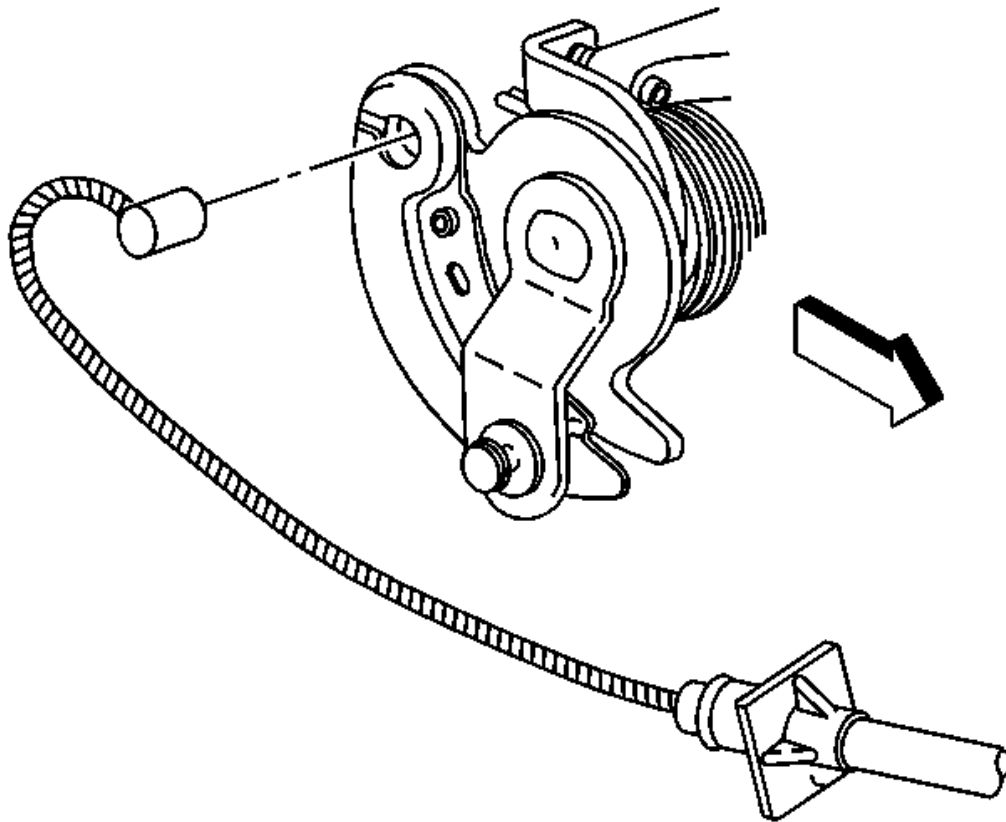

**Fig. 74: Identifying Accelerator Cable/Throttle Body Lever**  
**Courtesy of GENERAL MOTORS CORP.**

26. Install the accelerator cable onto the throttle body.