

G95D13212

Fig. 7: Identifying Push Rod, Anti-Rotation Bracket & Lifter
Courtesy of GENERAL MOTORS CORP.

CAMSHAFT

NOTE: To replace camshaft, engine must be removed from vehicle.

Removal

Remove engine. See **ENGINE**. Remove Cylinder head, valve lifters front cover, timing chain and camshaft sprocket. Remove oil pump drive from right side of cylinder block. Remove camshaft thrust plate. Remove camshaft. If necessary , use Camshaft Bearing Remover/Installer (J-33049) to remove camshaft bearings.

1996 Chevrolet Corsica

1996-97 ENGINES 2.2L 4-Cylinder VIN 4

Inspection

Inspect camshaft journal diameter, lobe lift and oil clearance. Replace components if not within specification. See CAMSHAFT table under ENGINE SPECIFICATIONS.

CAUTION: If installing new camshaft, Replace all lifters and add GM EP Lubricant (1051396) to engine oil. Verify use of oversize valve lifters. Oversize lifters are identified by mark on cylinder block, near lifter bore.

Installation

Install camshaft bearings (if removed), ensuring oil holes are aligned. Coat camshaft journals and bearings with Lubricant (1051396). Install camshaft. Install camshaft thrust plate. To complete installation, reverse removal procedure.

CRANKSHAFT REAR OIL SEAL

Removal

Remove transmission or transaxle. Remove flexplate/flywheel. See appropriate article in CLUTCHES (M/T models) or TRANSMISSION SERVICING (A/T models) below. Pry seal from housing, being careful not to damage sealing surface of crankshaft. Note direction of seal installation. See the following transmission removal articles:

TRANSMISSION REMOVAL & INSTALLATION - M/T (for Cavalier).

TRANSMISSION REMOVAL & INSTALLATION - A/T (for Century).

TRANSMISSION REMOVAL & INSTALLATION - A/T (for Cavalier & Sunfire).

TRANSMISSION REMOVAL & INSTALLATION - A/T (for Beretta & Corsica).

Installation

1. Coat inner and outer seal surfaces with engine oil. Install seal on mandrel of

Seal Installer (J-34686) until dust lip bottoms against tool collar. See **Fig. 8**. Align seal installer dowel pin with alignment hole of crankshaft. Install seal installer on crankshaft.

2. Tighten seal installer bolts to 27-62 INCH lbs. (3-7 N.m). Tighten seal installer handle until collar is even with cylinder block. Remove seal installer. To complete installation, reverse removal procedure. Apply thread locking compound to flexplate/flywheel bolts.

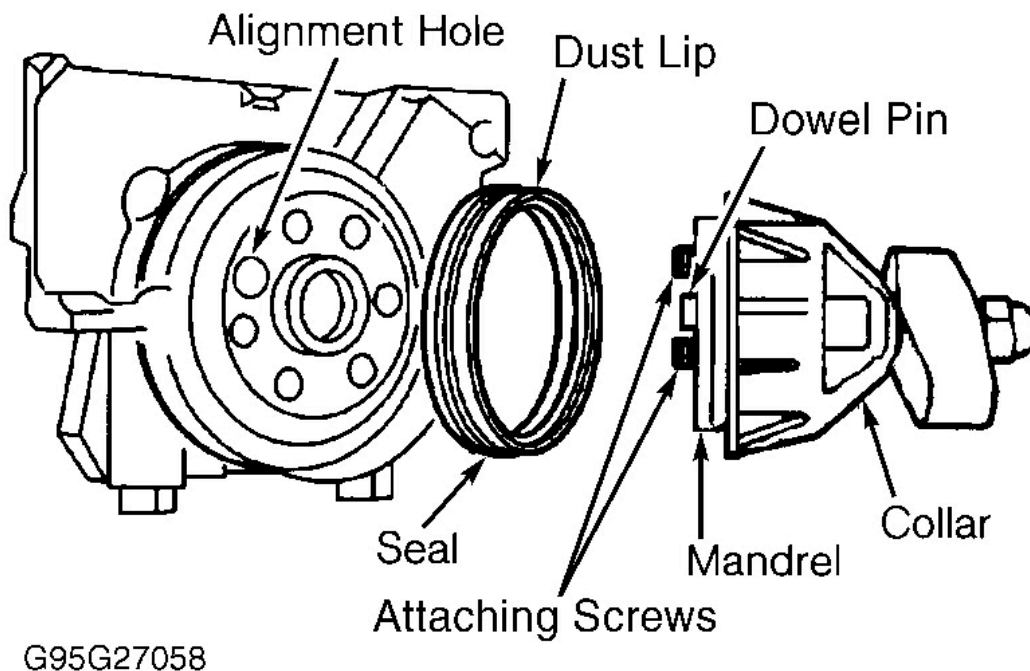

Fig. 8: Installing Rear Crankshaft Seal
Courtesy of GENERAL MOTORS CORP.

THERMOSTAT

Removal

1. Drain the cooling system. Refer to **DRAINING & FILLING COOLING SYSTEM**.
2. Remove the lower radiator hose from thermostat outlet.

1996 Chevrolet Corsica

1996-97 ENGINES 2.2L 4-Cylinder VIN 4

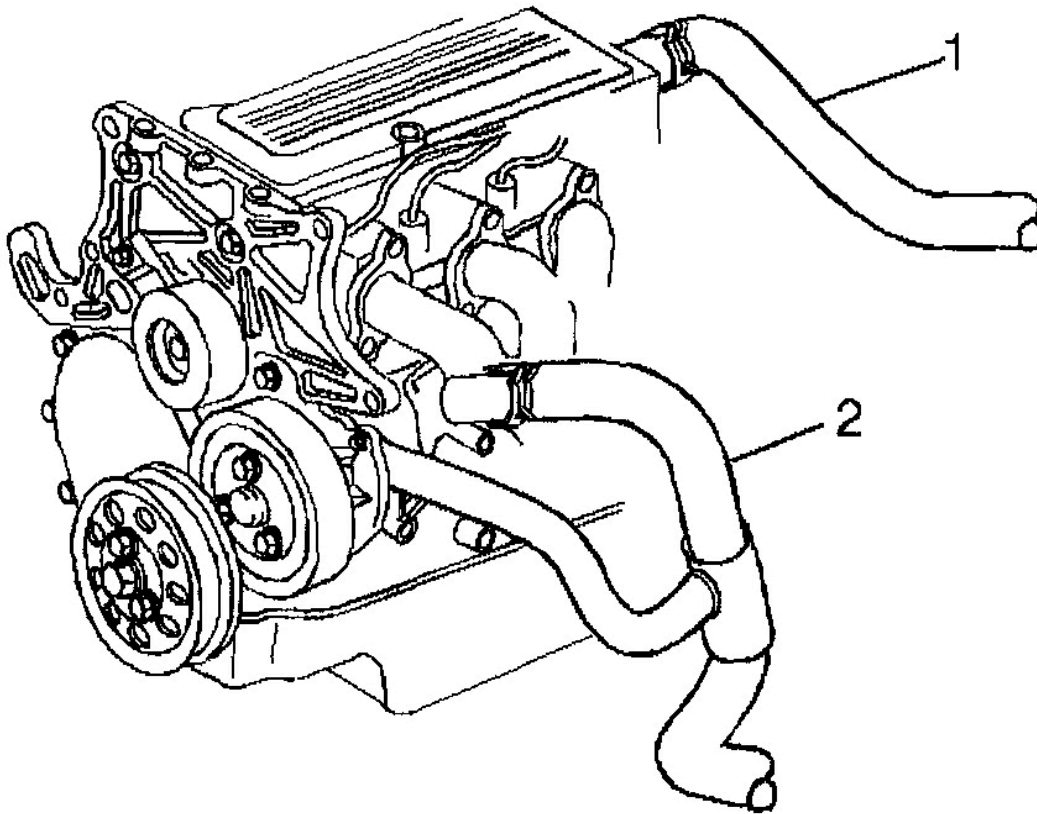

G01777963

Fig. 9: Radiator Outlet Hose
Courtesy of GENERAL MOTORS CORP.

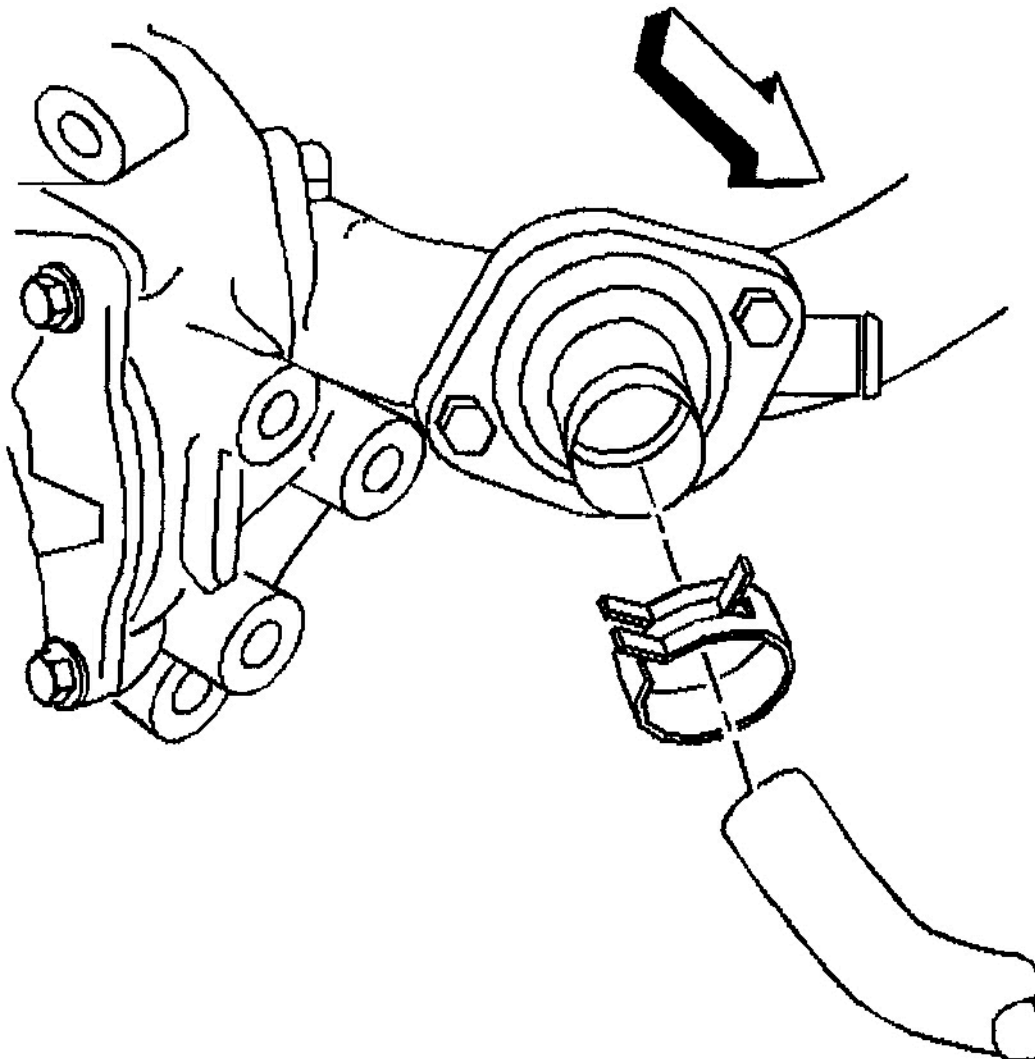

G01777977

Fig. 10: Thermostat Outlet
Courtesy of GENERAL MOTORS CORP.

3. Remove the thermostat outlet bolts and outlet.
4. Remove the thermostat.
5. Clean the mating surfaces of the radiator outlet and the radiator outlet pipe.

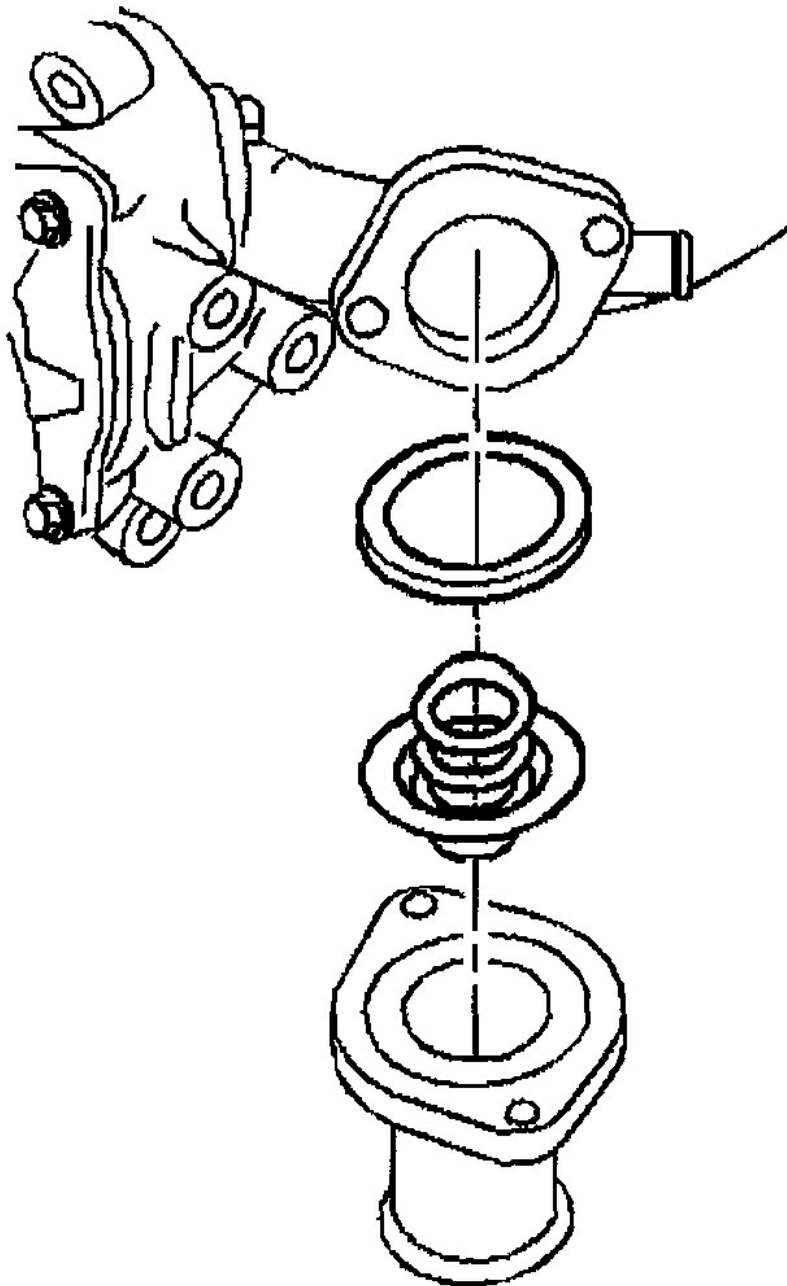

G01777979

Fig. 11: Thermostat Housing & Thermostat
Courtesy of GENERAL MOTORS CORP.

Installation

1. Install the thermostat.