

35. Install O-ring to motor flange groove. Figure 126.

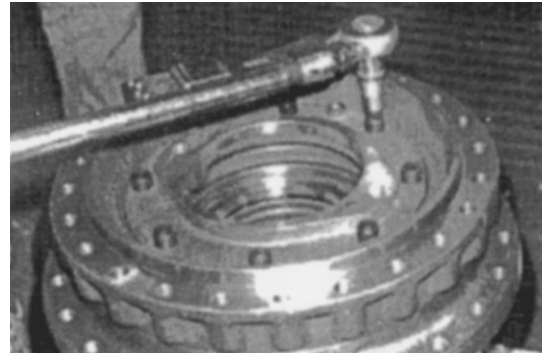

**Figure 126**

36. Tighten motor flange to hub. Figure 127.

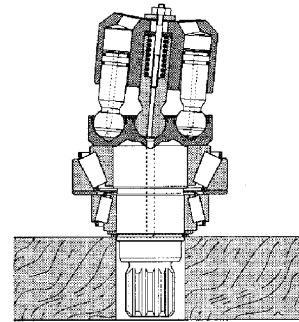

**Figure 127**

# TRAVEL MOTOR REASSEMBLY

## Rotary Group Assembly

1. Rotary group completely assembled ready for assembly.



HTS050S

Figure 128

2. Place assembly sleeve.

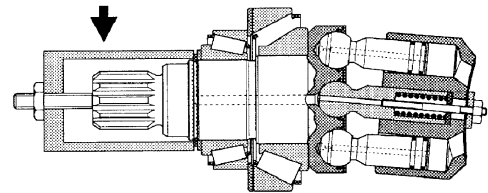

Figure 129

3. Warm up housing to 80°C (176°F).

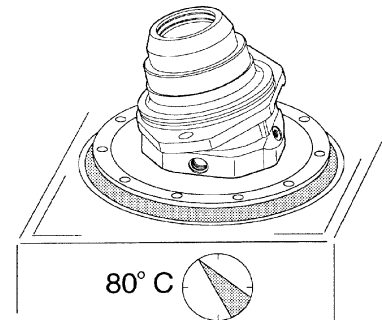

Figure 130

4. insert rotary group into housing to seat position.

I

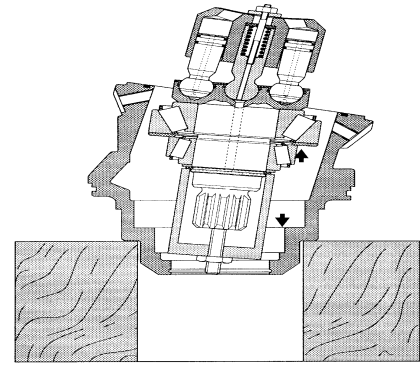

Figure 131

5. Fix zero position of cylinder with  $Q_{max}$ -screw.
6. Disassemble cylinder fixing screw.
7. Insert O-ring.

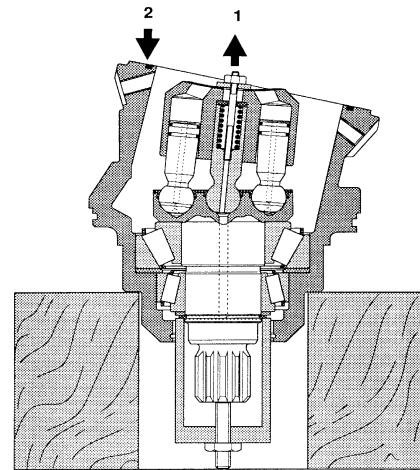

Figure 132

## Rotary Group Adjustment (See Serve Information)

1. Determine cylinder swivel range to max. angle with screw.

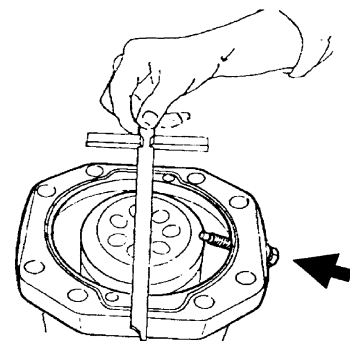

Figure 133