

Powertrain Power Distribution Module Removal and Installation

4. Gently squeeze the PDM housing and install the two retaining clips. See [Fig. 4](#).
5. Close the PDM cover.

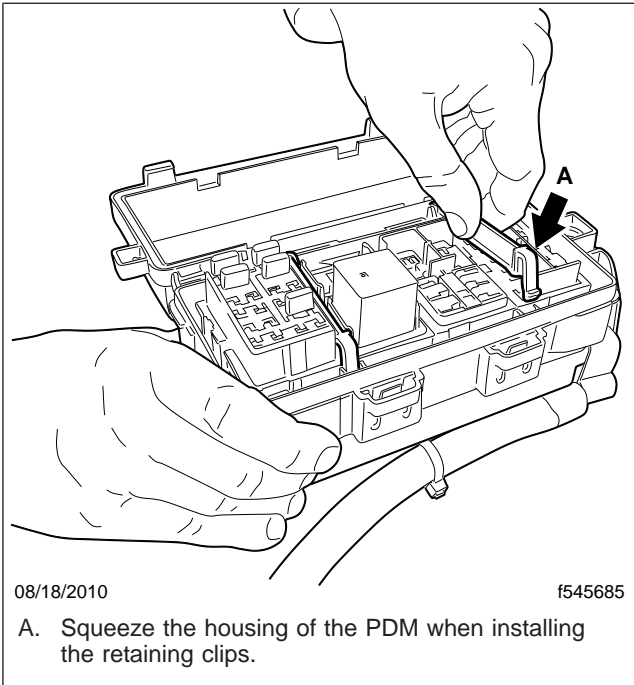

Fig. 4, Installing the Retaining Clips

6. Install the PDM housing onto the bracket, if it was removed.
7. Connect the batteries and close the hood.

Body Lighting PDM Removal and Installation

Removal

1. Disconnect the batteries at the negative terminals.
2. Open the cover and remove the two retaining clips. See **Fig. 1**.

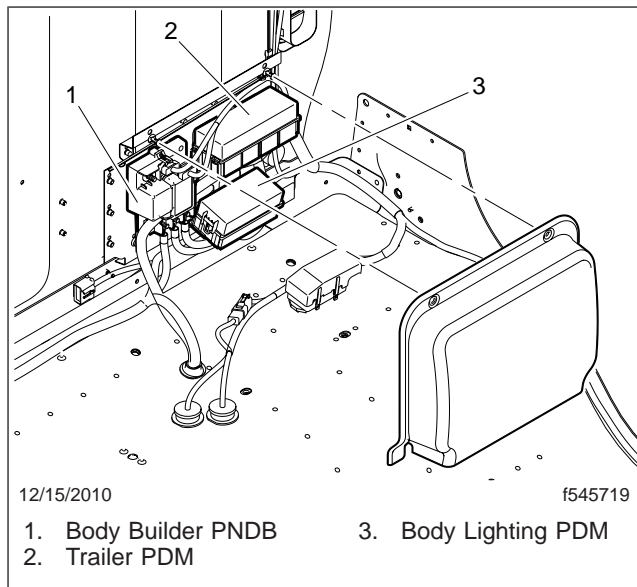

Fig. 1, Power Distribution Modules

3. Place the PDM block assembly into the housing, and connect the power feed circuits to the buss bar.
4. Gently squeeze the PDM housing and install the two retaining clips.
5. Close the PDM cover.
6. Install the PDM housing onto the bracket, if it was removed.
7. Connect the batteries and close the hood.

3. Lift the PDM block assembly out from the housing. The power feed circuits can be disconnected from the bus when the block assembly is about half way out of the housing.
4. Identify the positions and values of the fuses and relays, then remove them.
5. Lift the terminal locks up and out of the PDM.
6. Label all the wires before removing them from the PDM. Remove the wires.
7. Remove the PDM from the vehicle.

Installation

1. Insert each circuit into the bottom of the PDM block assembly. If the terminal is backward, the lock will not seat into place.
2. Install the terminal locks and the fuses and relays, as previously noted.

PNDB Removal and Installation

Removal

1. Disconnect the batteries.
 2. Open the hood.
- NOTE: The powernet distribution box (PNDB) is located on the cab frontwall, next to the bulkhead module. See **Fig. 1**.
3. Disconnect the battery and power cables from the PNDB. See **Fig. 2**.
 4. Disconnect the cab load disconnect switch (CLDS) connector, if equipped.
 5. Disconnect the keep-alive circuit connector from the PNDB.
 - 5.1 Using a flat-head screwdriver, push the red locking tab up.

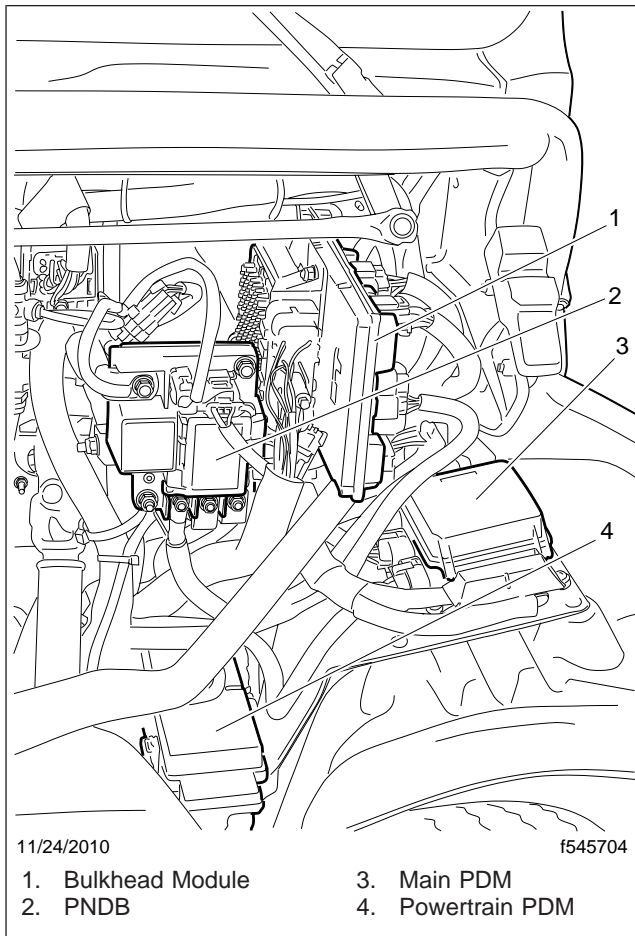

Fig. 1, Power Distribution Modules (EPA10 shown)

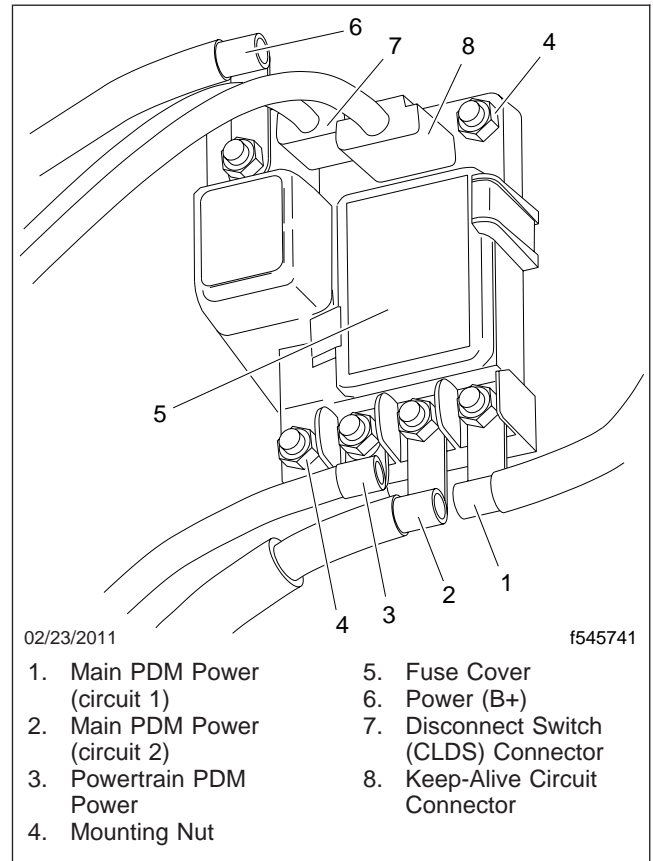

Fig. 2, Powernet Distribution Box

- 5.2 Press and release the tab, then remove the connector.
6. Remove the two mounting nuts.
7. Remove the PNDB from the vehicle.

Installation

1. Position the PNDB on the frontwall, and attach the two mounting nuts.
2. Connect the battery and power cables.
3. Attach the keep-alive circuit connector and the CLDS connector.
4. Connect the keep-alive circuit.
5. Connect the batteries.
6. Close the hood.

Troubleshooting

MEGA Fuses

MEGA fuses must be measured using a voltmeter when in the circuit or with an ohm meter when out of the circuit to determine if they are open. There is no visual method of determining continuity.

Powernet Distribution Box (PNDB)

Each powernet distribution box (PNDB) on the vehicle provides up to 4 low amperage circuits (30 amp and less), and up to three high amperage circuits through midi fuses. The fuses are located behind a cover on the face of the PNDB. On vehicles equipped with a cab load disconnect switch (CLDS), the high amperage circuits are switched on and off with the CLDS. The low amperage circuits are always live. Vehicles may have one or two PNDDBs and both are connected to the same CLDS.

When the CLDS is in the on position, an LED on the switch, and another on the PNDB, will be illuminated. When there is an error condition with the PNDB system, the LED on the PNDB and CLDS may flash. A flashing LED indicates an error as well as an LED that remains on when the switch is off or no LED when the switch is on.

To test for open fuses, use conventional troubleshooting methods. The LED's in the PNDB and switch are not affected by open fuses or the circuits they connect.

NOTE: See [Table 1](#) to troubleshoot a switched PNDB system.

PNDB and CLDS Troubleshooting			
Step	Test Procedure	Test Result	Action
1	Check the power cables on the PNDB for proper torque. Open the cover and inspect the MIDI fuse fastener torque and for discoloration caused by excessive heat.	Loose fasteners or heat discoloration	Determine if the fasteners can be properly torqued or if the PNDB needs replacement. Repair or replace as required.
		All OK	Go to step 2.
2	Does the LED on the PNDB flash in a constant pattern when the CLDS is switched to the OFF or ON position or does the LED on the PNDB just randomly flicker?	Constant Repeating Flashing Pattern	Troubleshoot and repair any wiring faults on circuits 425D, 425F, or circuit 425G between the CLDS and the PNDB. If there is no wiring fault, replace the CLDS.
		Random flickering	Replace the PNDB.
		No	Go to step 3.

Troubleshooting

PNDB and CLDS Troubleshooting			
Step	Test Procedure	Test Result	Action
3	Measure for ground on PNDB connector 1, pins 1 and 6. If either of these pins are not populated with a wire disregard measuring the unpopulated pin.	Yes	Measure the voltage on PNDB connector X1, pin 4. If pin 4 is at about 11 volts then troubleshoot and repair for a wiring fault in circuits 425D, 425F, 425G between the CLDS and the PNDB and for an open or short circuit in the CLDS. If there is no wiring or switch fault, replace the PNDB.
	Is ground present in the wiring harness supplying these pins?	No	Repair an open ground circuit to the PNDB.

Table 1, PNDB and CLDS Troubleshooting

See **Fig. 1**, **Fig. 2**, **Fig. 3**, and **Fig. 4** for illustrations of the connectors with pin identification.

NOTE: PNDB connector X2 is not part of the switching and control system. See **Table 3** for information on the function of PNDB connector X2.

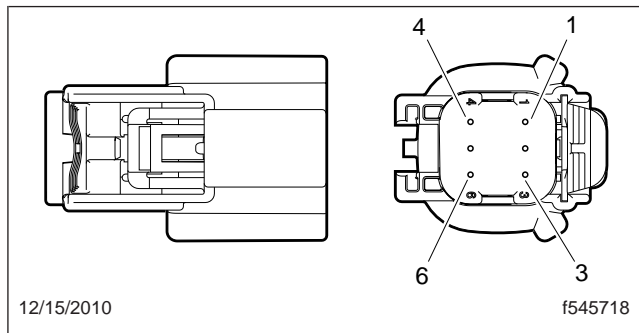

Fig. 1, Wire Insertion View of PNDB Connector X1

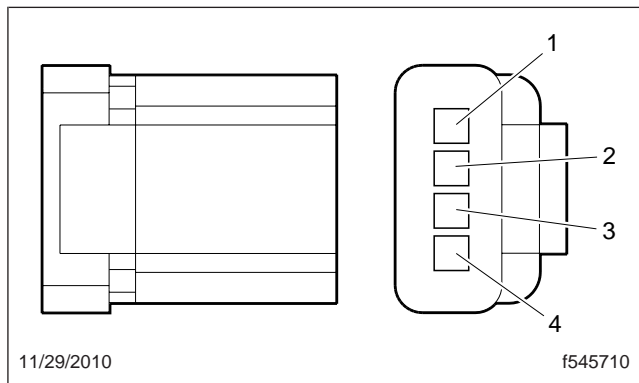

Fig. 2, Wire Insertion View of PNDB Connector X2

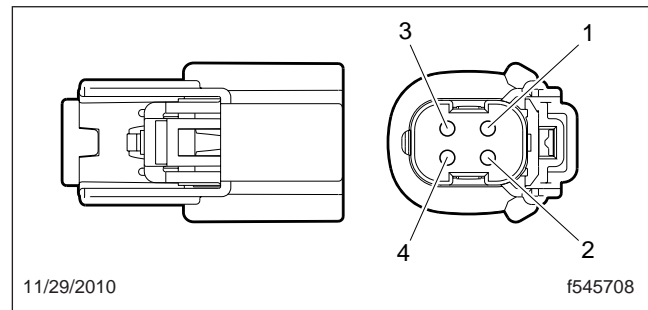

Fig. 3, Wire Insertion View of CLDS Connector X1

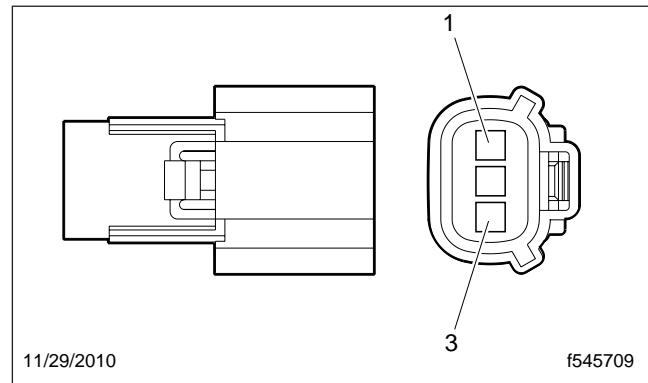

Fig. 4, Wire Insertion View of CLDS Connector X2