

SECTION 4 UNDERCARRIAGE

Group 2 Travel Device

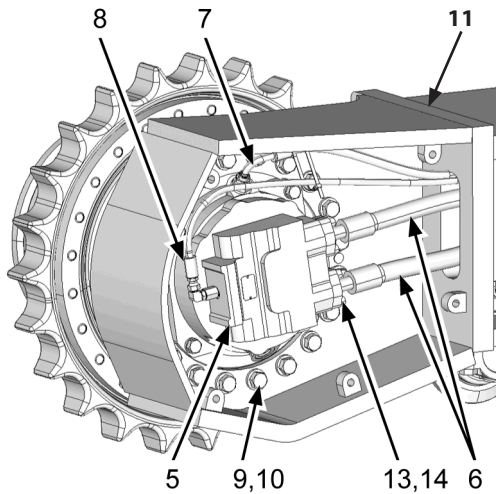

WJAA-04-02-014

Installation

1. Install all removed adapters to travel device (5).

CAUTION: Travel device (5) weight:

ZX470-6/490-6 Class: 680 kg

ZX530-6 Class: 860 kg

2. Attach nylon slings onto travel device (5). Hoist travel device (5). Install travel device (5) with washers (10) (20 used) (ZX530-6 Class: 24 used) and bolts (9) (20 used) (ZX530-6 Class: 24 used).

 : 32 mm

 : 750 N·m

3. Connect hose (8).

 : 19 mm

 : 30 N·m

4. Connect hose (7).

 : 27 mm

 : 80 N·m

5. Connect hoses (6) (2 used) with flanges (14) (4 used) and socket bolts (13) (8 used).

 : 10 mm

 : 90 N·m

SECTION 4 UNDERCARRIAGE

Group 2 Travel Device

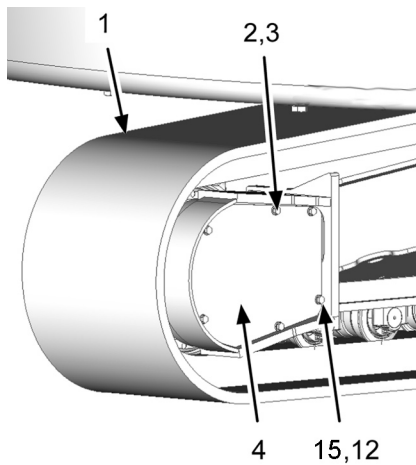

WJAA-04-02-013

6. Connect track (1). (Refer to W4-7-1.)
7. Install another travel device in the same way as step 1 to step 6.
8. Bleed air from the hydraulic system. (Refer to W1-4-1.)

IMPORTANT: Check the hydraulic oil level. Start the engine and check for any oil leaks. In order to prevent the travel motor from seizing, perform the break-in operation after installing.

Condition: 1. Engine speed: Slow idle speed





2. Travel mode switch: Slow speed

3. Perform forward and reverse travel operation (0.5 to 1 m) five or more times.

⚠ CAUTION: Cover (4) weight:

ZX470-6/490-6 Class: 32 kg

ZX530-6 Class: 38 kg

9. Install eyebolts (M16, Pitch 2 mm) to the bolt (2) holes. Attach nylon slings onto the eyebolts. Hoist cover (4).
10. Install cover (4) with spring washers (12) (5 used) and bolts (15) (5 used).
 : 24 mm
 : 210 N·m
11. Install washers (3) (2 used) and bolt (2).
 : 24 mm
 : 210 N·m
12. Install another cover (4) in the same way as step 9 to step 11.