

• **Front cylinder (cont'd)**

Turn the cam chain tensioner shaft completely in (clockwise) and secure it using the stopper tool. This tool can easily be made from a thin (1 mm thickness) piece of steel.

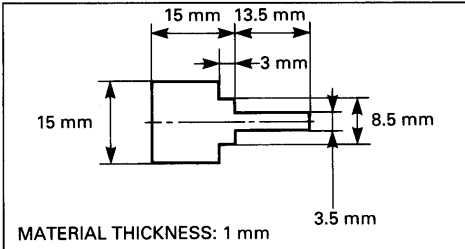

Install a new gasket and cam chain tensioner.

Torque the cam chain tensioner mounting bolts.

**Torque: 12 N·m (1.2 kg·m, 9 ft·lb)**

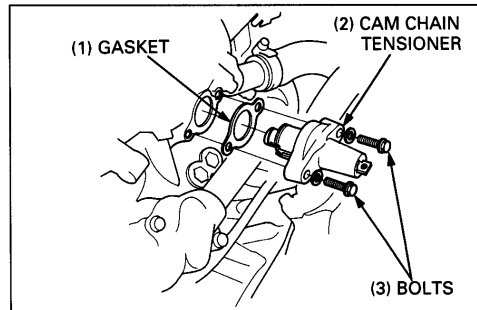
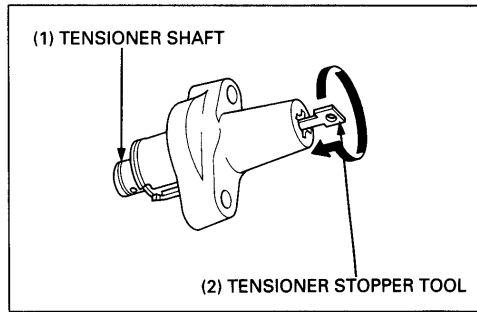

Remove the cam chain tensioner stopper tool.

Install the cam chain tensioner sealing bolt and washer.

Make sure the timing marks on the camshaft sprockets are level with the cylinder head upper edge.

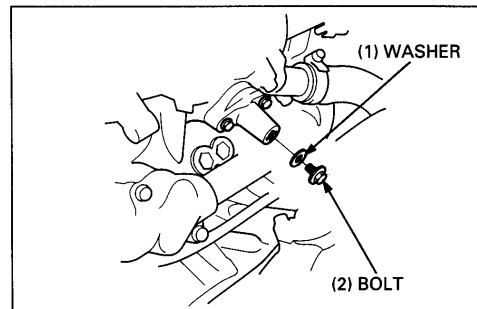

**When The Rear Cylinder Camshaft Only Was Removed**

Align the "T2" mark with the index mark on the right crankcase cover. Remove the front cylinder head cover (page 8-2).

Make sure #2 cylinder is TDC on the compression stroke.

If it is not, turn the crankshaft clockwise 360° and make sure "T2" mark aligns with the index mark on the right crankcase cover.

Rotate the crankshaft clockwise 270° to align the "T1" mark with the index mark on the right crankcase cover.

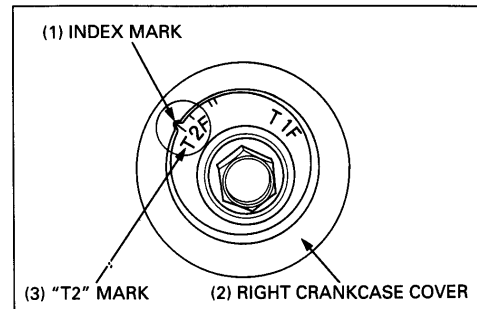

## Cylinder Head/Valves

Install the camshaft holder dowel pins in the rear cylinder head.

Lubricate the camshaft journal surfaces, camshaft holder and cam lobes with molybdenum disulfide oil.

Install the camshafts onto the rear cylinder head.

Check that the "R-EX" timing mark on the rear exhaust camshaft sprocket is level with the cylinder head upper edge as shown.

Check that the "R-IN" timing mark on the rear intake camshaft sprocket is level with the cylinder head upper edge as shown.

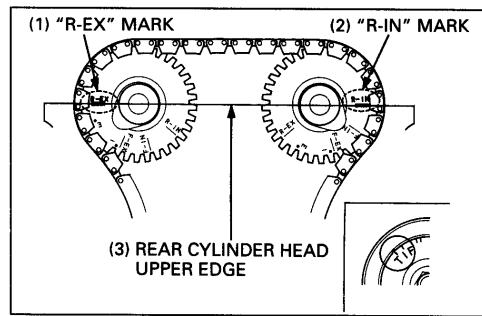

Install the camshaft holders in the correct positions, checking the identification marks on the holders and cylinder head.

Install the cam chain guide.

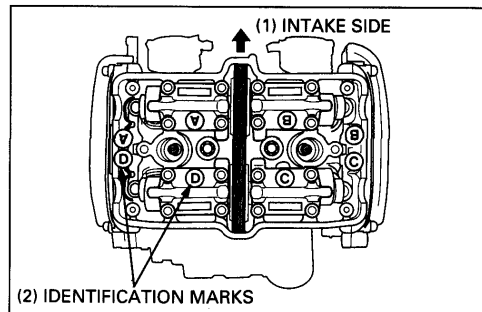

Torque the cam shaft holder bolts in the sequence shown.

**Torque: 12 N·m (1.2 kg·m, 9 ft·lb)**

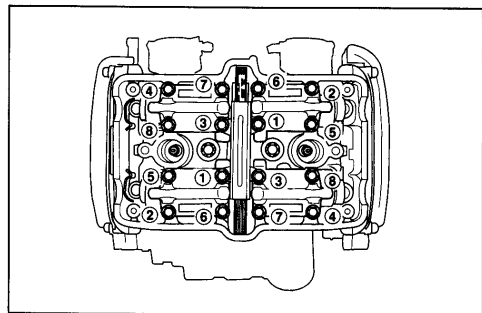

Turn the cam chain tensioner shaft completely in (clock-wise) and secure it using the special tool.

**S. TOOL**

**Tensioner stopper**

**07NMG - MY90100**  
**(Not available in U.S.A.)**

Cam chain tensioner stopper tool can easily be made from a thin (1 mm thickness) piece of steel.

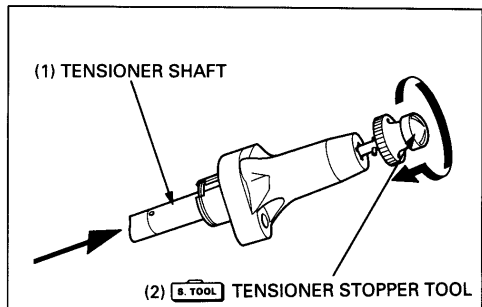
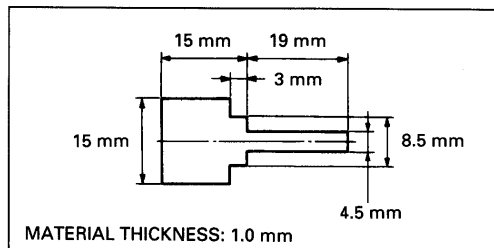

Install a new gasket and cam chain tensioner.

Torque the cam chain tensioner mounting bolts.

**Torque: 12 N·m (1.2 kg·m, 9 ft·lb)**

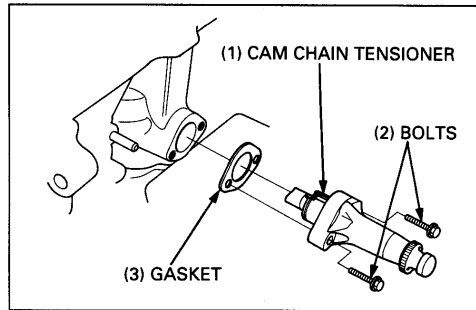

Remove the cam chain tensioner stopper tool.

Install the cam chain tensioner sealing bolt and washer.

Make sure the timing marks on the camshaft sprockets are level with the cylinder head upper edge.

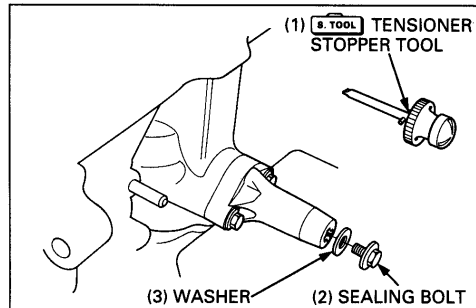

**When The Front Cylinder Camshaft Only Was Removed**

Align the "T1" mark with the index mark on the right crankcase cover.

Remove the rear cylinder head cover (page 8-2).

Make sure #1 cylinder is TDC on the compression stroke.

If it is not, turn the crankshaft clockwise 360° and make sure "T1" mark aligns with the index mark on the right crankcase cover.

Rotate the crankshaft clockwise 90° to align the "T2" mark with the index mark on the right crankcase cover.

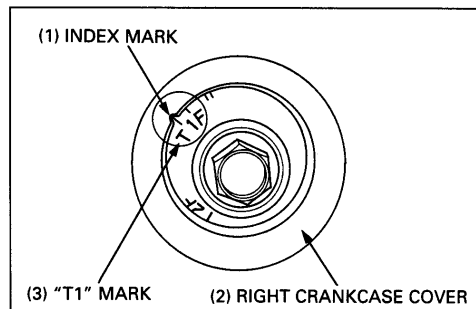

Install the camshaft holder dowel pins onto the front cylinder head.

Lubricate the camshaft journal surface, camshaft holder and cam lobes with molybdenum disulfide oil.

Install the camshafts onto the front cylinder head. Check that the "F-EX" timing mark on the front exhaust camshaft sprocket is level with the cylinder head upper edge as shown.

Check that the "F-IN" timing mark on the front intake camshaft sprocket is level with the cylinder head upper edge as shown.

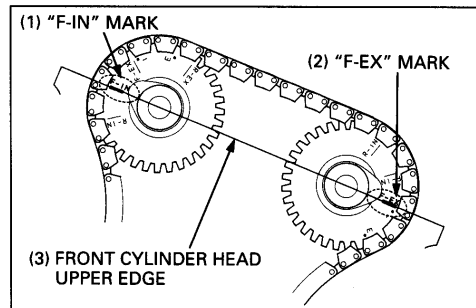

## Cylinder Head/Valves

Install the camshaft holders in the correct positions, checking the identification marks on the holders and cylinder head.

Install the cam chain guide.

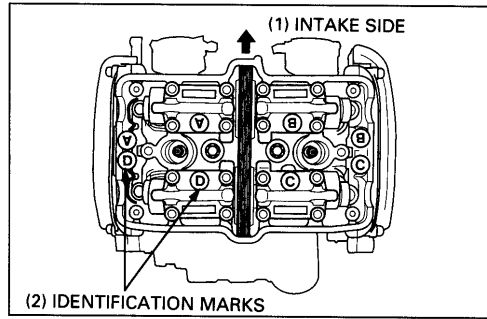

Torque the cam shaft holder bolts in the sequence as shown.

**Torque: 12 N·m (1.2 kg·m, 9 ft·lb)**

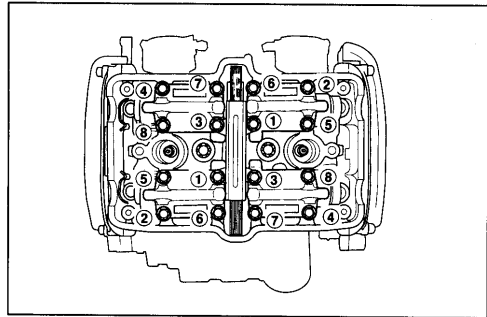

Turn the cam chain tensioner shaft completely in (clockwise) and secure it using the stopper tool. This tool can easily be made from a thin (1 mm thickness) piece of steel.

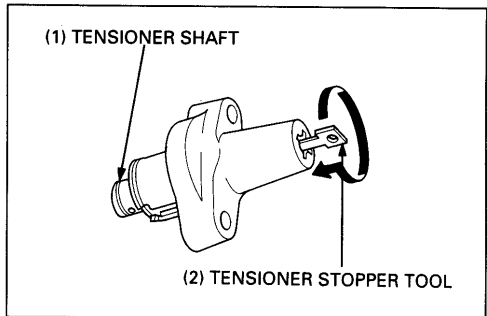
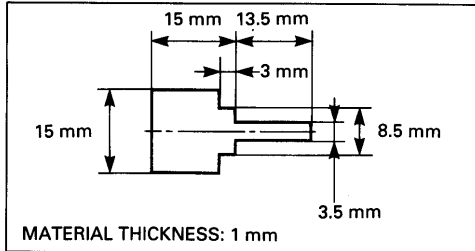

Install a new gasket and cam chain tensioner.

Torque the cam chain tensioner mounting bolts.

**Torque: 12 N·m (1.2 kg·m, 9 ft·lb)**

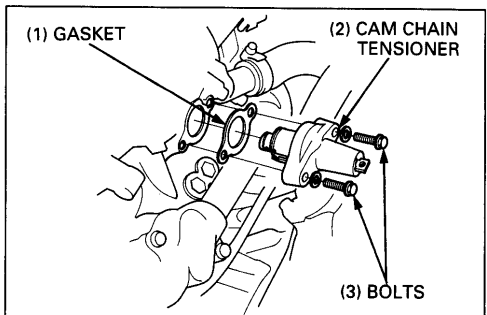

Remove the cam chain tensioner stopper tool.

Install the cam chain tensioner sealing bolt and washer.

Make sure the timing marks on the camshaft sprockets are level with the cylinder head upper edge.

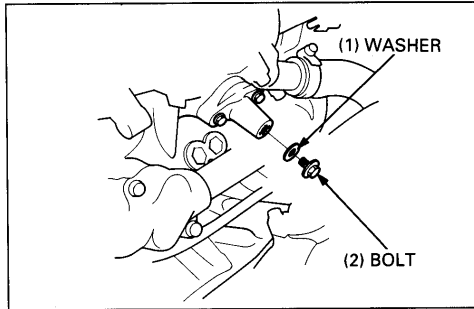

### Valve Cotter Removal/Installation

Remove the valve lifters and shims.

#### NOTE

- Mark the positions of all valve lifters and shims to ensure correct reassembly.
- It is easy to remove the valve lifter with a valve lapping tool or magnet.
- Remove the shims with tweezers or a magnet.

Install the tappet hole protector into the valve lifter bore.



**Tappet hole protector**

**07HMG – MR70002**  
Not available in U.S.A

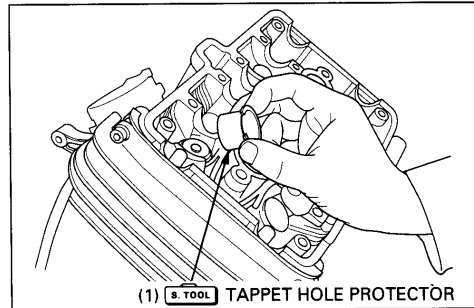

Install the valve spring compressor onto the valve and compress the valve spring.

#### CAUTION:

- To prevent loss of tension, do not compress the valve springs more than necessary.

Remove the valve cotters.



**Valve spring compressor**

**07757 – 0010000**

**Valve spring compressor attachment**

**07959 – KM30101**

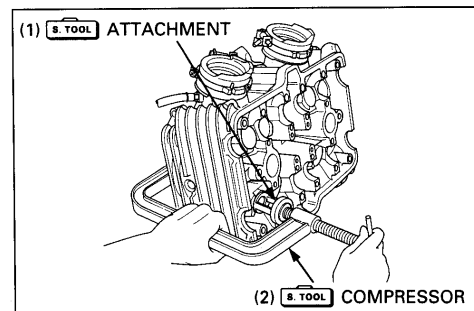

(2) S. TOOL COMPRESSOR

Installation is in the reverse order of removal.

### Cylinder Head Bolt Installation

Apply engine oil to the seating surface and threads, then tighten the cylinder head mounting bolts gradually in a crisscross pattern in the order as shown.

#### Torque:

**6 mm bolt: 12 N·m (1.2 kg·m, 9 ft·lb)**

**9 mm bolt: 44 N·m (4.4 kg·m, 32 ft·lb)**

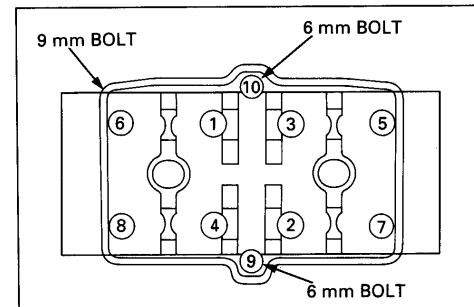

---

# 9. Clutch System

<b>Service Information</b>	<b>9-1</b>	<b>Clutch Removal</b>	<b>9-4</b>
<b>Troubleshooting</b>	<b>9-1</b>	<b>Clutch Installation</b>	<b>9-6</b>
<b>Right Crankcase Cover Removal/ Installation</b>	<b>9-2</b>		

## Service Information

- Clutch maintenance can be done with the engine in the frame.
- Transmission oil viscosity and level have an effect on clutch disengagement. When the clutch does not disengage or the vehicle creeps with clutch disengaged, inspect the transmission oil level before servicing the clutch system.

## Troubleshooting

### Clutch Slips When Accelerating

- Incorrect clutch adjustment
- Worn clutch discs
- Weak clutch springs
- Transmission oil mixed with molybdenum or graphite additive

### Motorcycle Creeps With The Engine Idling

- Incorrect clutch adjustment
- Clutch plates warped
- Faulty clutch lifter
- Incorrect engine oil weight

# Right Crankcase Cover Removal/Installation

