

CLUTCH SYSTEM

Return to Main Table of Contents

CLUTCH	2
CLUTCH PEDAL	8
CLUTCH CONTROL	10
CLUTCH MASTER CYLINDER	13
CLUTCH RELEASE CYLINDER	15
CLUTCH COVER AND DISC	17

GENERAL SPECIFICATIONS

Clutch operating method	Hydraulic type
Clutch disc	
Type	Single dry with diaphragm.
Facing diameter	215 x 140 (8.5 x 5.9)
(Outside x Inside)mm (in.)	
Clutch cover assembly	
Type	Diaphragm 'spring strap
Setting load N (lb)	3680-4320 (827-971)
Clutch release cylinder	
I.D.mm (in.)	20.64 (0.81)
Clutch master cylinder	
I.D.mm (in)	15.87 (0.62)

• I.D. : Inside Diameter

SERVICE STANDARD

Standard value	
Clutch disc thickness	8.6±0.5mm(0.33±0.1 in.)
Clutch pedal height	182 mm (7.0 in.) : For 1.6 DOHC 189 mm (7.4 in.) : For 1.8 DOHC
Clutch pedal free play	6-13 mm (0.24 -0.51 in.)
Clutch pedal to floorboard clearance (when the clutch is disengaged)	70 mm (2.8 in.)
Clutch pedal stroke	145 mm (5.7 in.) : For 1.6 DOHC 155 mm (6.1 in.) : For 1.8 DOHC
Limit	
Clutch disc rivet sink	0.3 mm (0.012in.)
Diaphragm spring end height difference	0.5 mm (0.02 in.)

TIGHTENING TORQUE

	Nm	kg.cm	lb.ft
Clutch pedal to pedal support member (clutch pedal bracket)	19-28	190-280	14-20
Clutch pedal support member	17-21	170-210	12-15
Ignition lock switch	19-28	190-280	14-20
Clutch master cylinder to firewall	9-14	90-140	7-10
Clutch tube flare nut	13-17	130-170	9-12
Clutch tube bracket	4-6	40-60	3-4
Reservoir band	5-7	50-70	4-5
Clutch release cylinder mounting bolt	20-27	200-270	14-20
Clutch release cylinder to union bolt	20-25	200-250	14-18
Clutch cover assembly	15-22	150-220	11-16
Clutch master cylinder push rod lock nut	10-15	100-150	7-11

LUBRICANTS

Items	Specified lubricants	Quantity
Contact surface of release bearing and fulcrum of clutch release fork	MOLYWHITE TA NO.2	As required
Inner surface of clutch release bearing	MOLYWHITE TA NO.2	As required
Inner surface of clutch release cylinder and outer circumference of piston and cup	Brake fluid DOT3	As required
Inner surface of clutch disc spline	MOLYWHITE TA NO.2	As required
Inner surface of clutch master cylinder and outer circumference of piston assembly	Brake fluid DOT3	As required
Clutch master cylinder push rod, clevis pin and washer	Wheel bearing grease SAE J310a, NLGI No.2	As required
Clutch pedal shaft and bushings	SAE J310a, Chassis grease (NLGI-0)	As required
Contact portion of release fork to release cylinder push rod	MOLYWHITE TA NO.2	As required
Input shaft spline	MOLYWHITE TA NO.2	As required

SPECIAL TOOLS

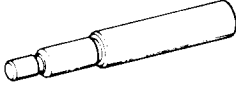
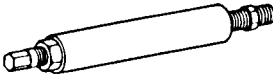
Tool (Number and name)	Illustration	Use
09411-11000 Clutch disc guide		Centering flywheel and clutch disc
09414-24000 Lock pin remover		Removal of lock pin

TROUBLESHOOTING

Symptom		Probable cause	Remedy
Clutch slipping o Car will not respond to engine speed during acceleration. o Insufficient car speed o Lack of power during Uphill driving		Insufficient pedal free play	Adjust
		Clogged hydraulic system	Correct or replace parts
		Excessive wear of clutch disc facing	Replace
		Hardened clutch disc facing, or oil on surface	Replace
		Damaged pressure plate or flywheel	Replace
Difficult gear shifting (gear noise during shifting)		Weak or broken pressure spring	Replace
		Excessive pedal free play	Adjust
		Hydraulic system fluid leaks, air trapping or clogging	Repair or replace parts
		Unusual wear or corrosion of clutch disc spring	Replace
		Excessive vibration (distortion) of clutch disc	Replace
Clutch noisy	When clutch is not used	Insufficient play of clutch pedal	Adjust
		Excessive wear of clutch disc facing	Replace
	A noise is heard after clutch is disengaged	Unusual wear and/or damage of release bearing	Replace
	A noise is heard when clutch is disengaged	Insufficient grease on the sliding surface of bearing sleeve	Repair
Improperly installed clutch assembly or bearing		Repair	
	A noise is heard when car is suddenly rolled of with clutch partially engaged	Damaged pilot bushing	Replace
Hard pedal effort		Insufficient lubrication of clutch pedal	Repair
		Insufficient lubrication of spline part of clutch disc	Repair
		Insufficient lubrication of clutch release lever shaft	Repair
		Insufficient lubrication of front bearing retainer	Repair

Symptom	Probable cause	Remedy
Hard to shift or will not shift	Clutch pedal free play excessive	Adjust pedal free play
	Clutch release cylinder faulty	Repair release cylinder
	Clutch disc out of true, runout is excessive or lining broken	Inspect clutch disc
	Spline on input shaft or clutch disc dirty or burred	Repair as necessary
	Clutch pressure plate faulty	Replace clutch cover
Clutch slips	Clutch pedal free play insufficient	Adjust pedal free play
	Clogged hydraulic system	Repair or replace parts
	Clutch disc lining oily or worn out	Inspect clutch disc
	Pressure plate faulty	Replace clutch cover
	Release fork binding	Inspect release fork
Clutch grabs/chatters	Clutch disc lining oily or worn out	Inspect clutch disc
	Pressure plate faulty	Replace clutch cover
	Clutch diaphragm spring bent	Replace clutch cover
	Worn or broken torsion spring	Replace clutch disc
	Engine mounts loose	Repair as necessary
Clutch noisy	Damaged clutch pedal bushing	Replace clutch pedal bushing
	Loose part inside housing	Repair as necessary
	Release bearing worn or dirty	Replace release bearing
	Release fork or linkage sticks	Repair as necessary

SERVICE ADJUSTMENT PROCEDURE

CLUTCH PEDAL INSPECTION AND ADJUSTMENT

1. Measure the clutch pedal height (from the face of the pedal pad to the floorboard) and the clutch pedal clevis pin play (measured at the face of the pedal pad.)

Standard value : (A) 189 mm (7.4 in.) : For 1.8 DOHC
 182 mm (7.0 in.) : For 1.6 DOHC
 (B) 1-3 mm (0.04-0.12 in.)

2. If either the clutch pedal height or the clutch pedal clevis pin play are not within the standard value range, adjust as follows:

- 1) For vehicles without cruise control system, turn and adjust the bolt so that the pedal height is the standard value, and then secure by tightening the lock nut.
 Vehicles with cruise control system, disconnect the clutch pedal position switch connector and turn the switch for standard clutch pedal height. Then lock with the lock nut.

NOTE

When the pedal height is lower than the standard value, loosen the bolt or clutch pedal position switch, and then turn the push rod to make the adjustment. After the adjustment, tighten the bolt or clutch pedal position switch until it reaches the pedal stopper, and then lock with the lock nut.

- 2) Turn the push rod to adjust the clutch pedal clevis pin play to agree with the standard value and then secure the push rod with the lock nut.

CAUTION

When adjusting the clutch pedal height or the clutch pedal clevis pin play, be careful not to push the push rod toward the master cylinder.

3. After completing the adjustments, confirm that the clutch pedal free play (measured at the face of the pedal pad) and the distance between the clutch pedal (the face of the pedal pad) and the firewall when the clutch is disengaged are within the standard value ranges.

Standard value : (C) 6-13 mm (0.2-0.5 in.)
 (D) 70 mm (2.8 in.)

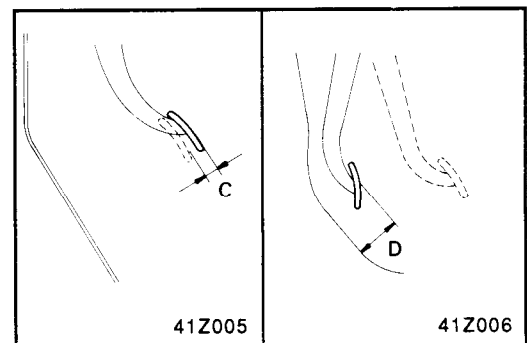
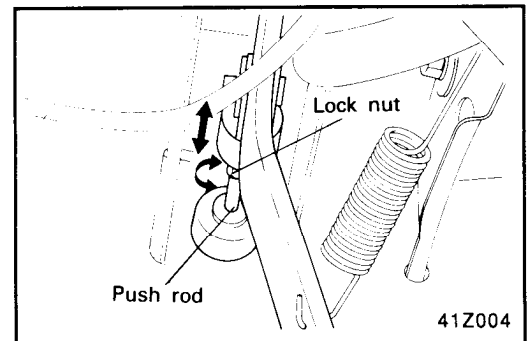
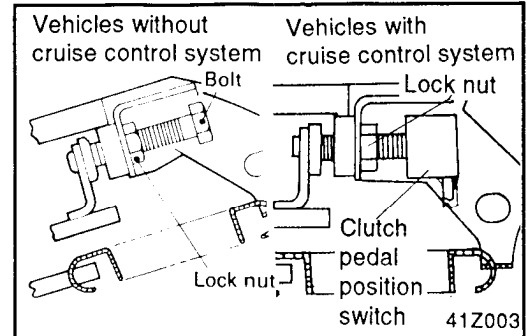
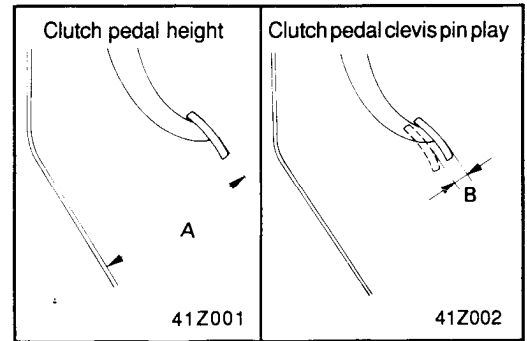

4. If the clutch pedal free play and the distance between the clutch pedal and the firewall when the clutch is disengaged do not agree with the standard values, after adjusting it is probably the result of either air in the hydraulic system or a faulty master cylinder or clutch. Bleed the air, or disassemble and inspect the master cylinder or clutch.

BLEEDING

Whenever the clutch tube, the clutch hose, and/or the clutch master cylinder have been removed, or if the clutch pedal is spongy, bleed the system.

CAUTION

Use the specified brake fluid.

Specified brake fluid : DOT3

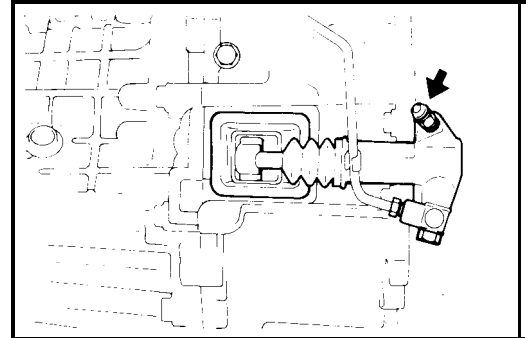

CLUTCH PEDAL

COMPONENTS

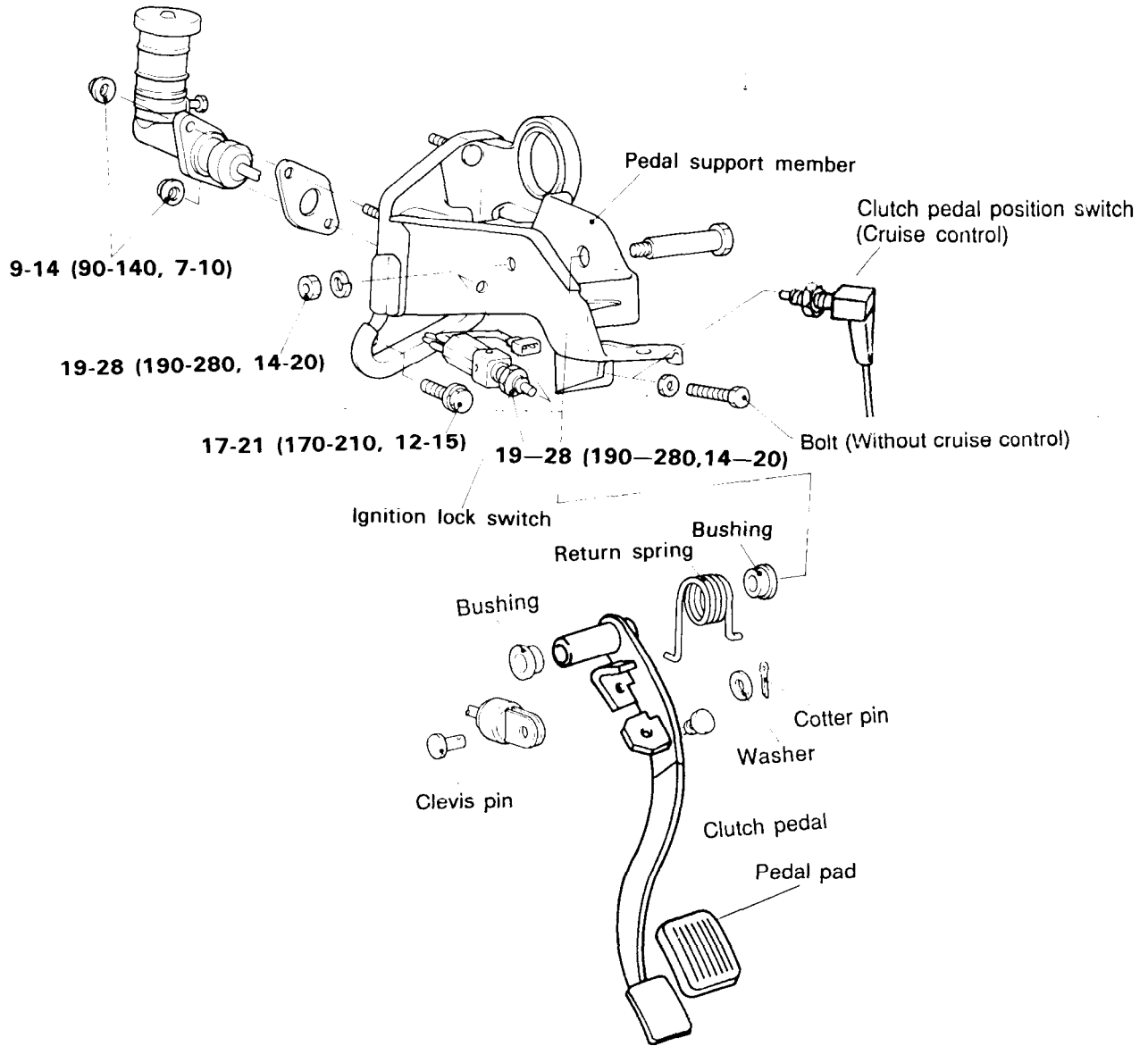

TORQUE : Nm (kg.cm, lb.ft)

Removal

1. Remove the cotter pin, washer and clevis pin.
2. Remove the clutch pedal mounting bolt.

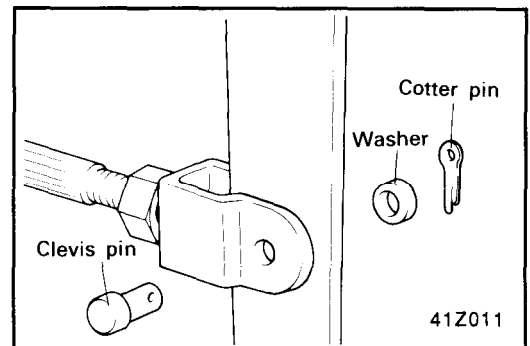

INSPECTION

1. Check the pedal shaft and bushing for wear.
2. Check the clutch pedal for bending or twisting.
3. Check the return spring for damage or deterioration.
4. Check the pedal pad for damage or wear.

IGNITION LOCK SWITCH INSPECTION

1. Disconnect the connector
2. Check to be sure that there is continuity between connector - terminals. (Refer to 27 GROUP Ignition Lock system)

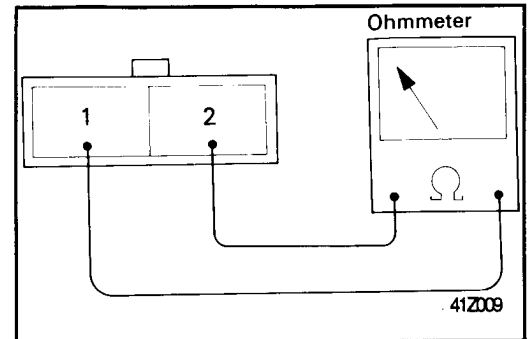
**INSTALLATION**

1. Installation is reverse of removal.
 2. Apply multi-purpose grease to the bushings.
-
3. Apply multi-purpose grease to the clevis pin and washer.

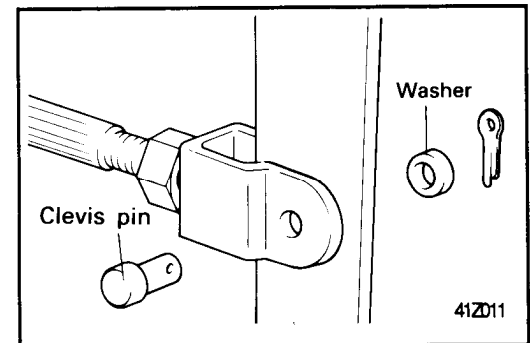
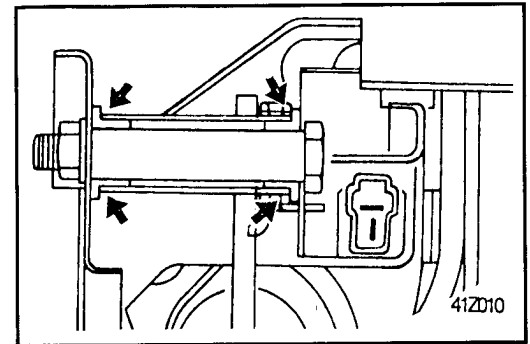

CLUTCH CONTROL

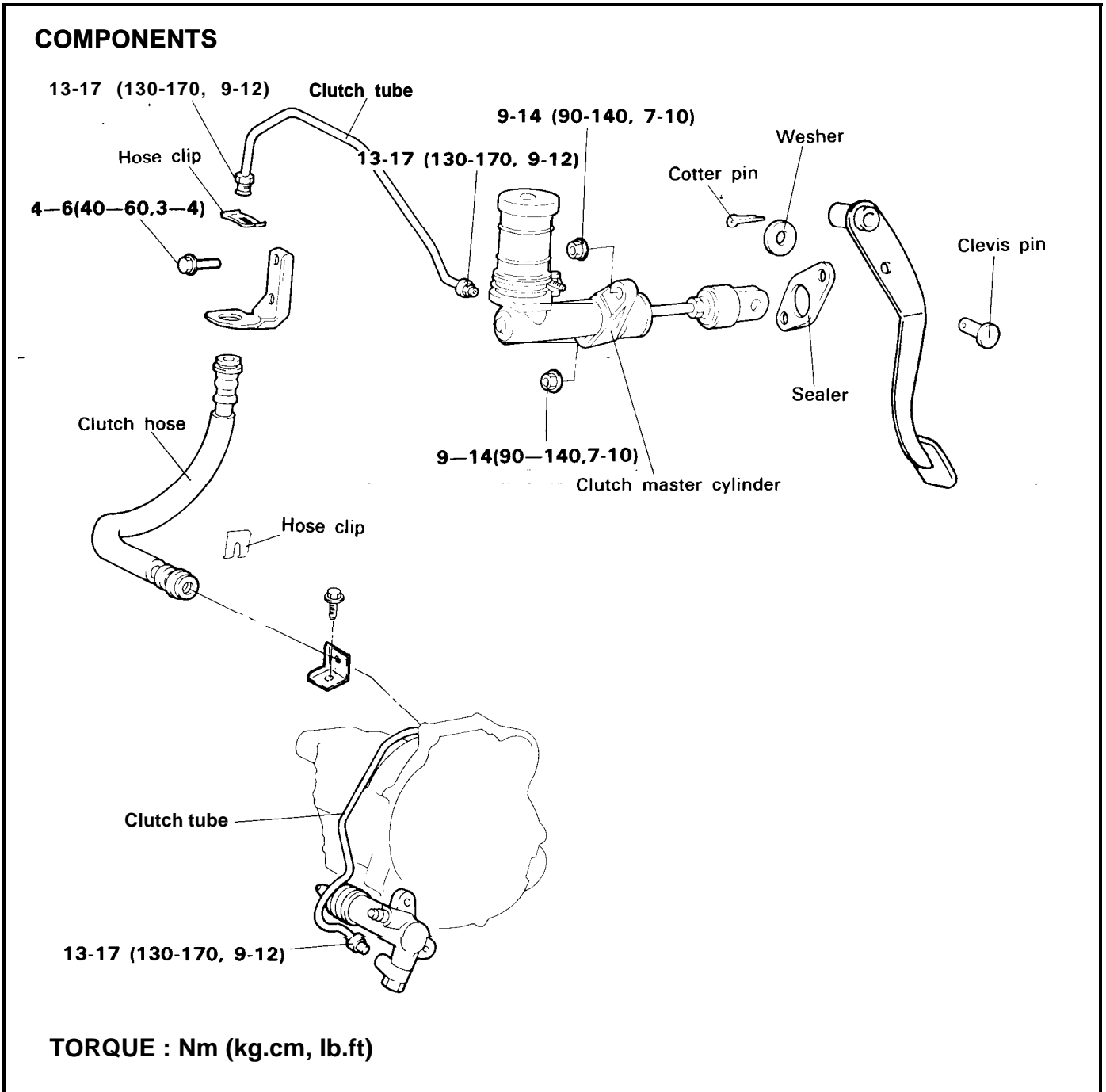

REMOVAL

1. Drain the clutch fluid through the bleed plug.
2. Remove the clevis pin, washer and cotter pin.
3. Disconnect the clutch line (master cylinder side).
4. Remove the master cylinder mounting bolt.

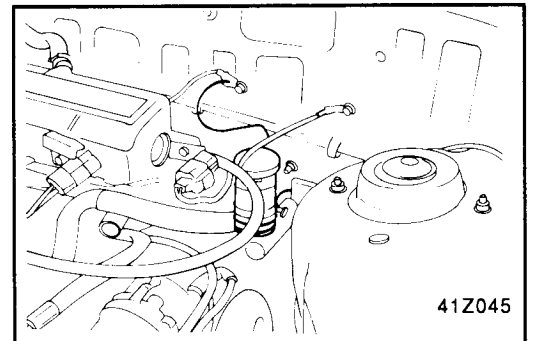

5. Remove the clutch line clips.
6. Hold the nut on the clutch hose and loosen the flare nut on the clutch line.

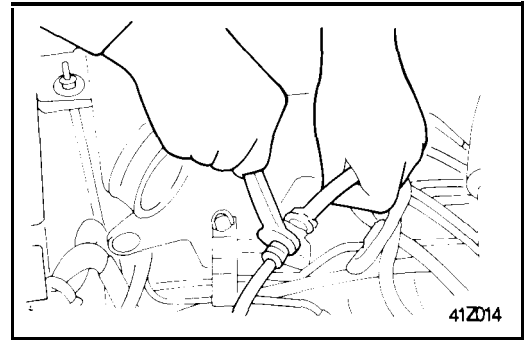

7. Remove the clip from the clutch hose and remove the hose from the bracket.
8. Remove the clutch line.

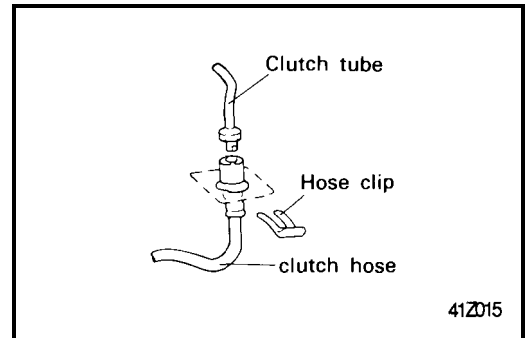

9. Disconnect the clutch line (release cylinder side).

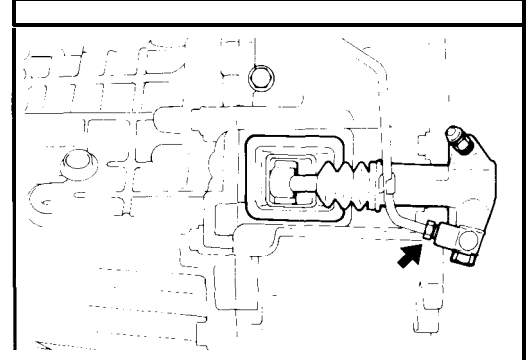

INSPECTION

1. Check the clutch hose or lines for cracks or restrictions.

INSTALLATION

1. Connect the clutch line (release cylinder side).

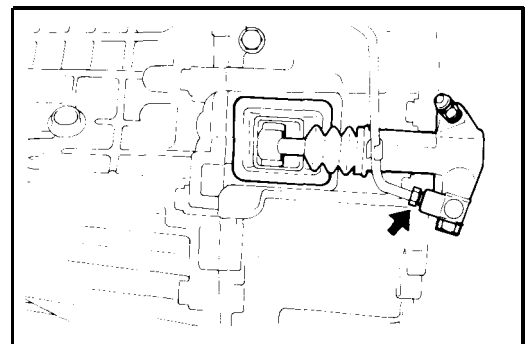

2. Temporarily tighten the flare nut by hand, then tighten it to the specified torque, being careful that the clutch hose does not become twisted.

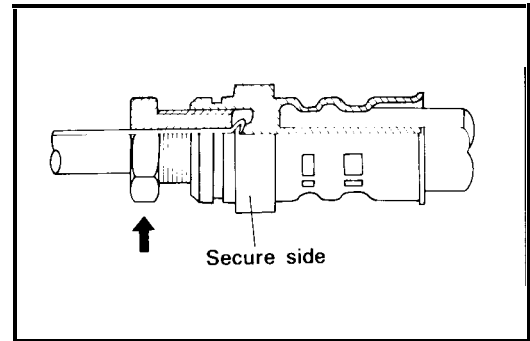

3. Install the clutch line and clips.

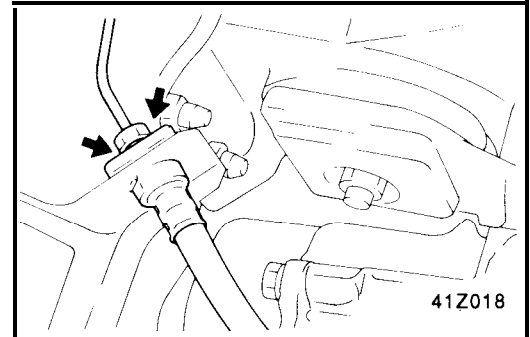

4. Install the master cylinder.

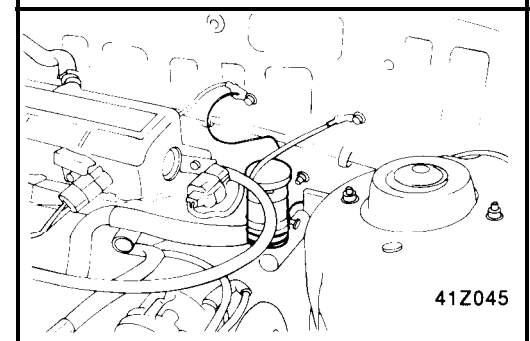

5. Apply the specified grease to the clevis pin and washer.

**Specified grease : Wheel bearing grease SAE J310a,
NLGI No.2**

6. Install the push rod to the clutch pedal.
7. Refill the clutch master cylinder with fluid.
8. Bleed the system.

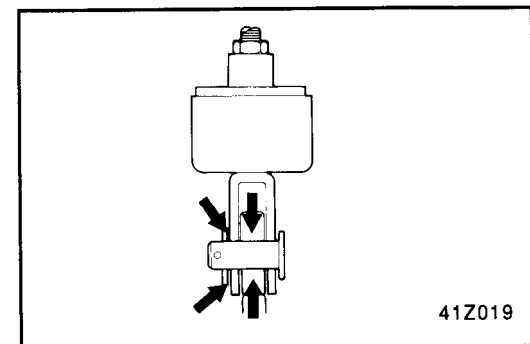

CLUTCH MASTER CYLINDER

COMPONENTS

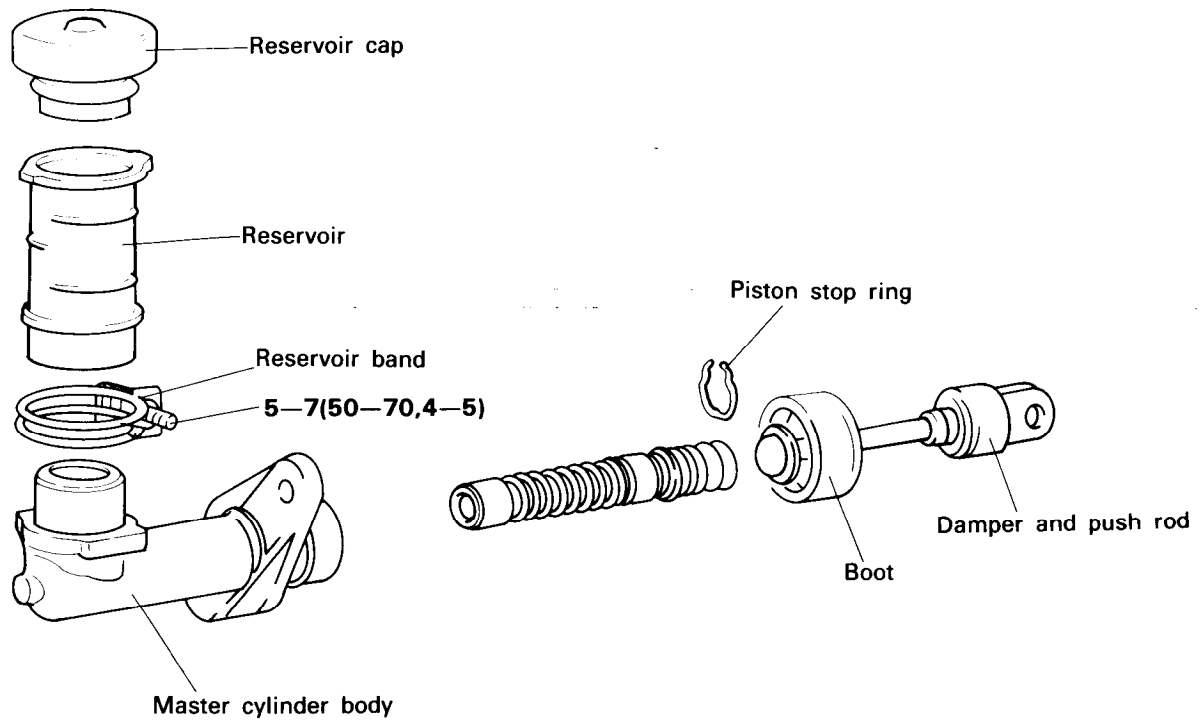

TORQUE : Nm (kg.cm, lb.ft)

DISASSEMBLY

1. Remove the piston stop ring.
2. Pull out the push rod and piston.
3. Remove the reservoir band, reservoir cap and reservoir.

NOTE

- 1) Use care not to damage the master cylinder body and piston assembly.
- 2) Do not disassemble the piston assembly.

INSPECTION

1. Check the inside of cylinder body for rust pitting or scoring.
2. Check the piston cup for wear or deformation.
3. Check the piston for rust, pitting or scoring.
4. Measure the master cylinder inside diameter with a cylinder gauge and the piston outside diameter with a micrometer.

NOTE

Measure the inside diameter of the master cylinder at three places (bottom, middle, and top), in perpendicular directions.

5. If the master cylinder-to-piston clearance exceeds the limit, replace the master cylinder and/or piston assembly.

Limit : 0.15 mm (0.006 in.)

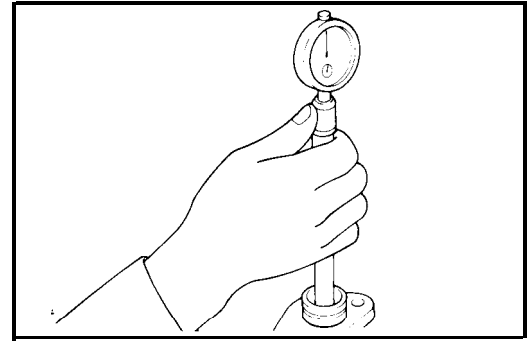
**REASSEMBLY**

1. After installing the reservoir to the master cylinder body, install the reservoir clamp within the range shown by the arrow in the illustration.

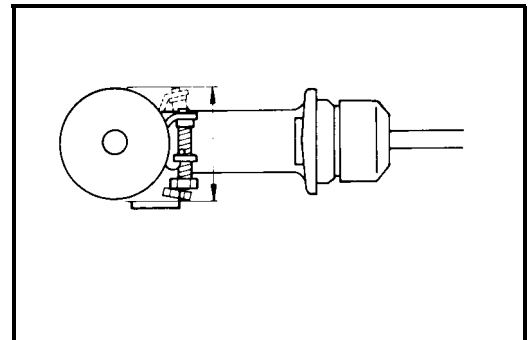

2. Apply the specified fluid to the inner surface of the cylinder body and to the outside of the piston assembly.

Specified fluid : BRAKE FLUID DOT 3

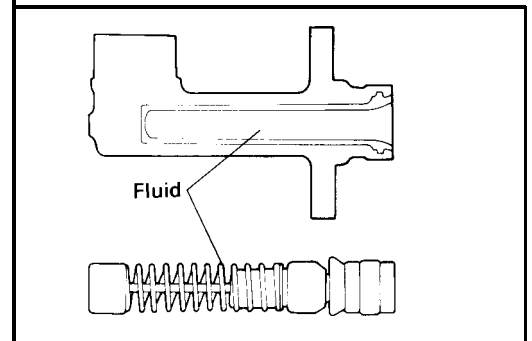

CLUTCH RELEASE CYLINDER

COMPONENTS

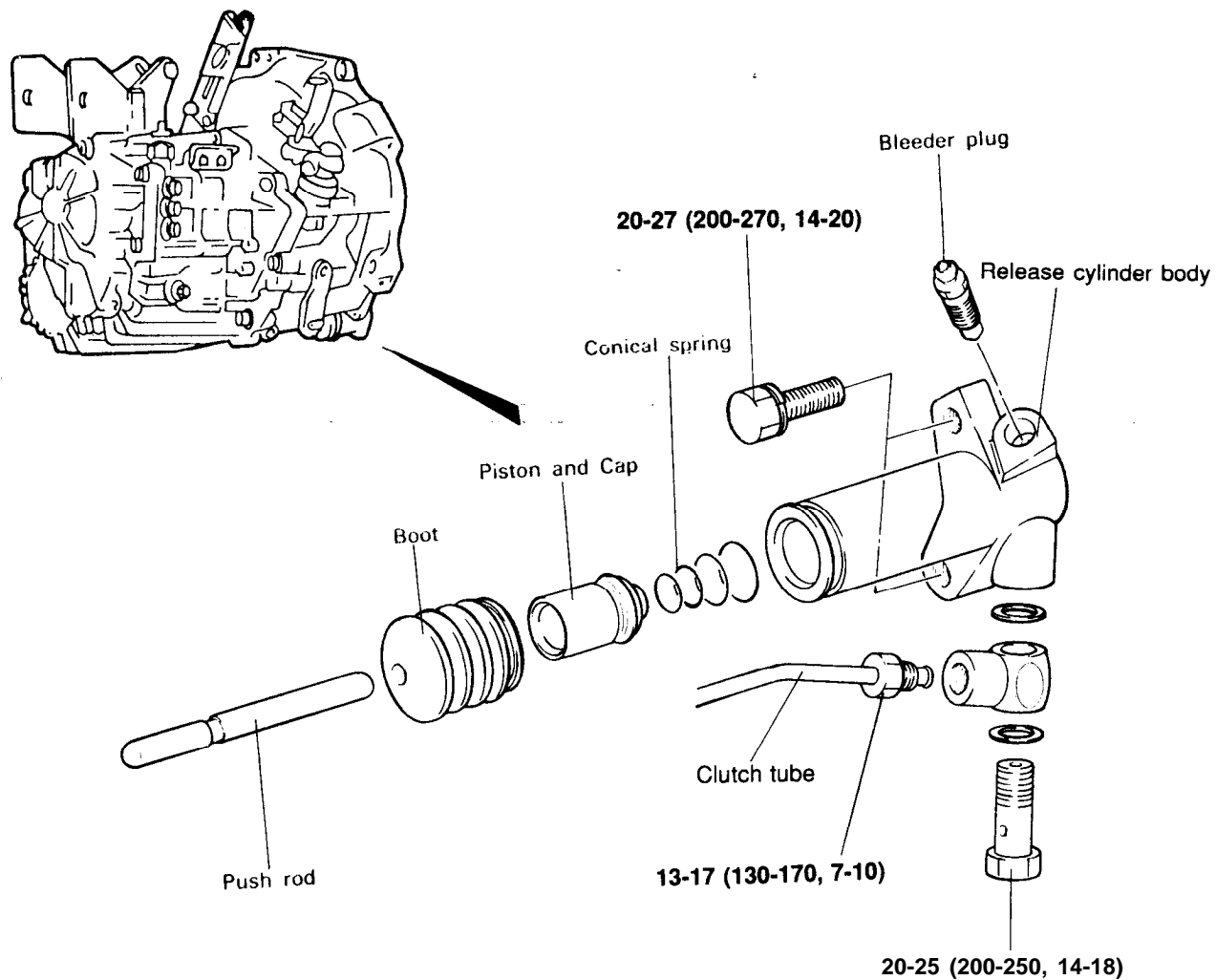

TORQUE : Nm (kg.cm, lb.ft)

REMOVAL

1. Disconnect the clutch line.
2. Remove the release cylinder mounting bolt.

INSPECTION

1. Check the clutch release cylinder for fluid leakage.
2. Check the clutch release cylinder boots for damage.

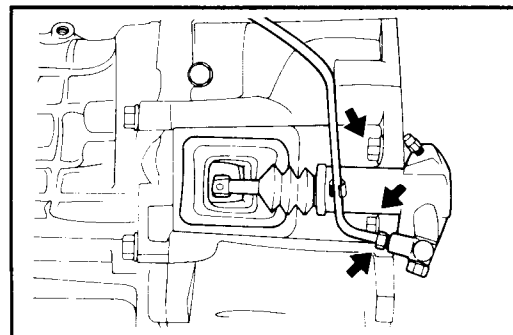

DISASSEMBLY

1. Remove the valve plate, spring, push rod. boots.
2. Remove the piston from the release cylinder using compressed air.

CAUTION

- 1) Cover with rags to prevent the piston from popping out.
- 2) Apply compressed air slowly to prevent brake fluid from splashing.

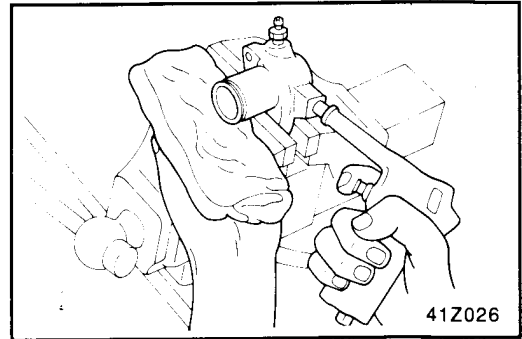
**INSPECTION**

1. Check the release cylinder bore for rust and damage.
2. Measure the release cylinder bore at three locations (bottom, -middle and top) with a cylinder gauge and replace the release cylinder assembly if the clearance to the piston outside exceeds the limit.

Limit : 0.15 mm (0.006 in.)

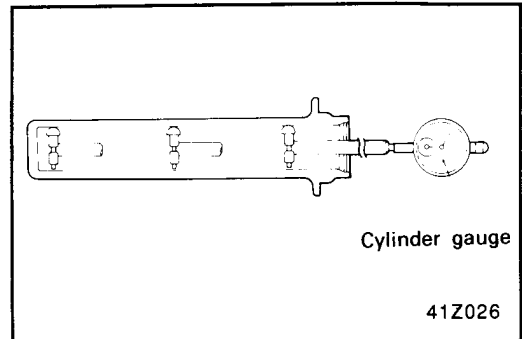

Cylinder gauge

REASSEMBLY

1. Apply specified brake fluid to the release cylinder body inside and outer surface of the piston and piston cup and push the piston cup assembly in the cylinder.

Specified fluid : BRAKE FLUID DOT 3

2. Install the valve plate, spring, union.

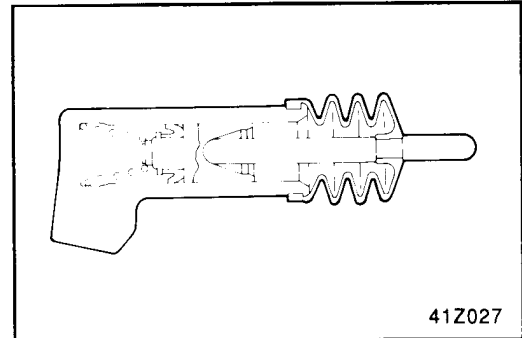
**INSTALLATION**

1. Apply a coating of the specified grease to the contact parts of the release fork and release cylinder push rod. (DOHC)

Specified grease : MOLYWHITE TA NO.2

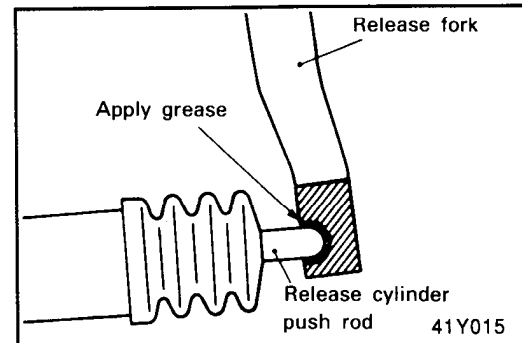

2. Install the clutch release cylinder, and the clutch tube.

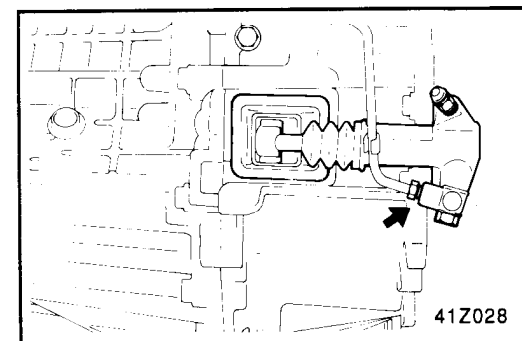

CLUTCH COVER AND DISC

COMPONENTS

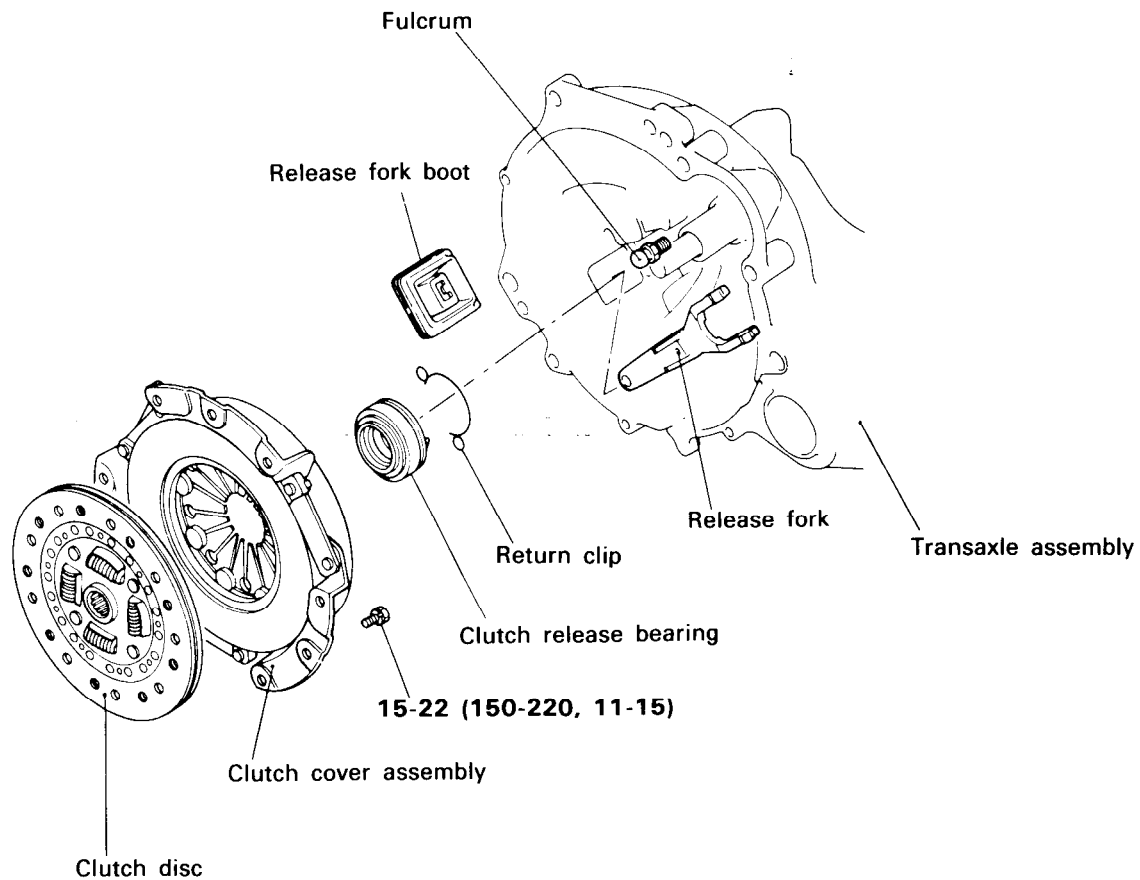

TORQUE : Nm (kg.cm, lb.ft)

REMOVAL

1. Remove the transaxle.
2. Insert the special tool (0941 I-I 1000) at the center spline (in order to prevent the clutch disc from falling).
3. Diagonally loosen bolts which attach clutch cover to flywheel. Back off bolts in succession, one or two turns at a time, to avoid bending cover flange.

NOTE:

DO NOT clean the clutch disc or release bearing with cleaning solvent.

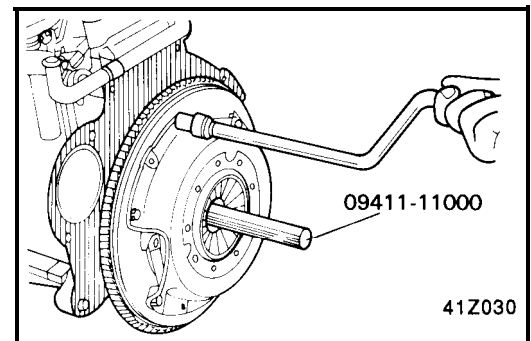

INSPECTION**CLUTCH COVER ASSEMBLY**

1. Check the diaphragm spring end for wear and uneven height.
2. Replace if wear is evident or height difference exceeds the limit.

Limit : 0.5 mm (0.02 in.)

3. Check the pressure plate surface for wear, cracks and color change.
4. Check the cover plate rivets for looseness and replace the clutch cover assembly if loose.

CLUTCH DISC

1. Check the facing for loose rivets, uneven contact, deterioration due to seizure, adhesion of oil or grease and replace the clutch disc if defective.
2. Measure the rivet sink and replace the clutch disc if it is out of specification.

Limit : 0.3 mm (0.012 in.)

3. Check for torsion spring play and damage and if defective, replace the clutch disc.
4. Combine the clutch disc with the input shaft and check sliding condition and check for play in the rotating direction.
If it does not slide smoothly, check after cleaning and reassembling. If the play is excessive, replace the clutch disc and/or the input shaft.

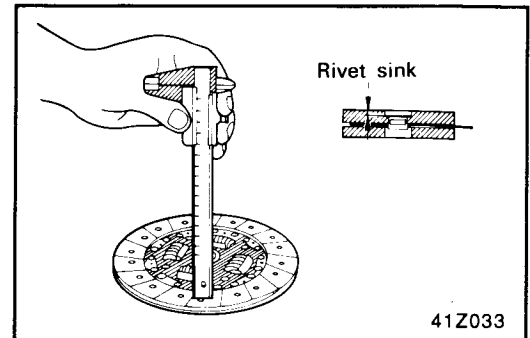
**CLUTCH RELEASE BEARING**

1. The release bearing is packed with grease, so don't use cleaning oil, etc. to clean it.
2. Check the bearing for heat damage, abnormal noise and/or improper rotation. Also check whether or not there is wear at the point of contact with the diaphragm spring.
3. If there is abnormal wear at the point of contact with the release fork, replace the bearing.

RELEASE FORK

1. If there is abnormal wear at the point of contact with the bearing, replace the release fork.

INSTALLATION

1. Apply a coating of the specified grease to the point of contact with the fulcrum and the point of contact with the release bearing.

Specified grease : MOLYWHITE TA No.2

NOTE

When installing the clutch, apply grease to each part, but be careful not to apply excessive grease; excessive grease will cause clutch slippage and shudder.

2. Apply a coating of the specified grease to the end of the release cylinder's push rod and to the push rod hole in the release fork.

Specified grease : MOLYWHITE TA NO. 2

3. Pack the inner surface of the clutch release bearing and the groove with the specified grease.

Specified grease : MOLYWHITE TA NO. 2

4. Apply multipurpose grease to the release bearing contact surfaces of the clutch release fork.

Specified grease : MOLYWHITE TA NO.2

5. Using the special tool (clutch disc guide), position the clutch disc to the flywheel.
6. Install the clutch cover assembly. Tighten the bolts a little at a time, working in a diagonal sequence, finally tightening them to the specified torque.
7. Before installing the transaxle assembly, apply a coating of the specified grease to the input shaft spline, and then rub in by using a brush.

Specified grease : MOLYWHITE TA NO.2

