

TIMING CHAIN

SEC. 120-130-135

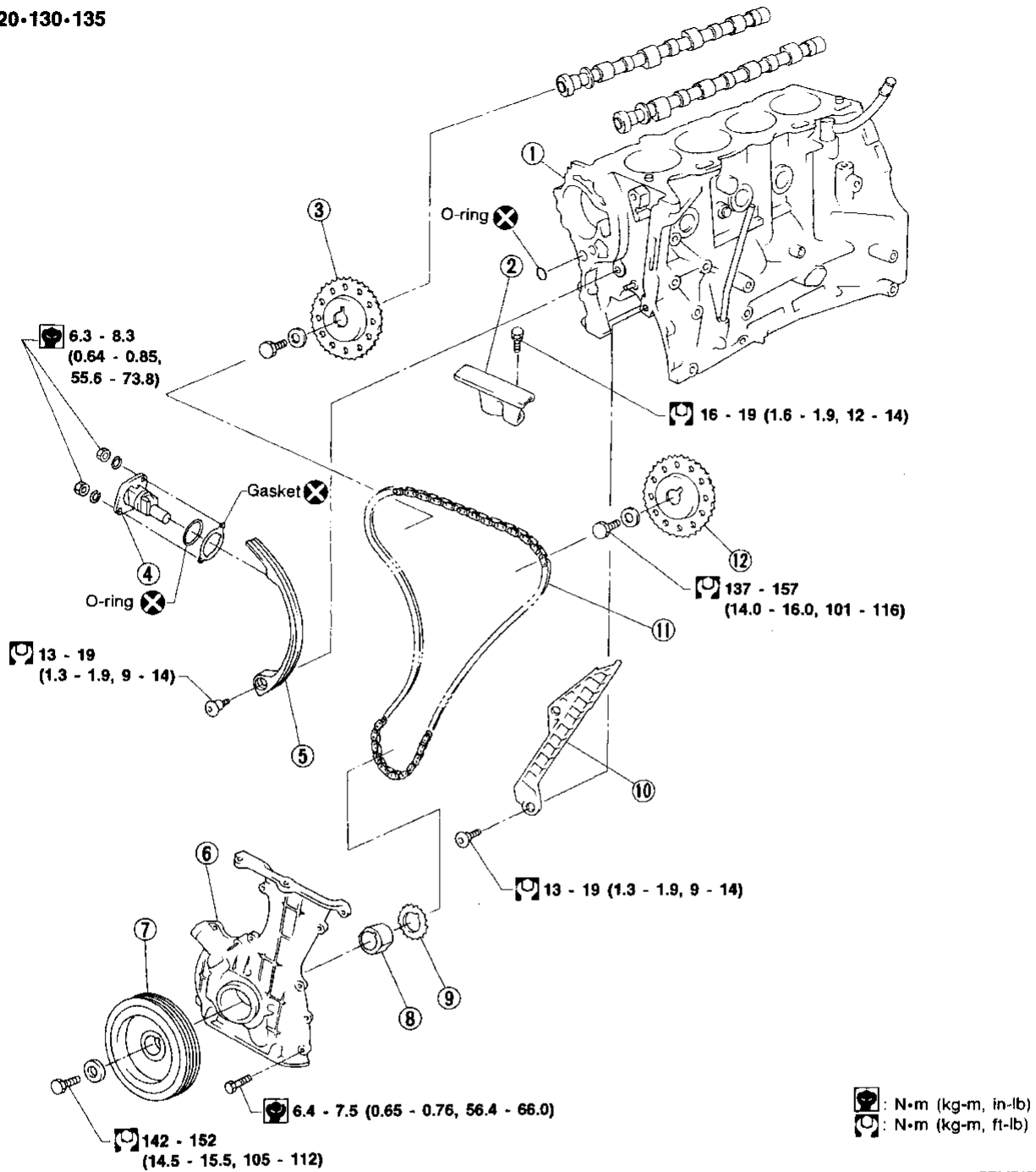

SEM718EB

- | | | |
|------------------------|-------------------|------------------------|
| ① Cylinder block | ⑤ Chain guide | ⑨ Crankshaft sprocket |
| ② Chain guide | ⑥ Front cover | ⑩ Chain guide |
| ③ RH camshaft sprocket | ⑦ Crank pulley | ⑪ Timing chain |
| ④ Chain tensioner | ⑧ Oil pump spacer | ⑫ LH camshaft sprocket |

TIMING CHAIN

CAUTION:

- After removing timing chain, do not turn crankshaft and camshaft separately, or valves will strike piston heads. CI
- When installing rocker arms, camshafts, chain tensioner, oil seals, or other sliding parts, lubricate contacting surfaces with new engine oil. MA
- Apply new engine oil to bolt threads and seat surfaces when installing cylinder head, camshaft sprockets, crankshaft pulley, and camshaft brackets. EM
- Do not spill engine coolant on drive belts. LC

Removal

1. Release fuel pressure.
Refer to EC section ("Fuel Pressure Release", "BASIC SERVICE PROCEDURE"). EC
2. Remove engine under covers. FE
3. Remove front RH wheel and engine side cover. CL
4. Drain coolant by removing cylinder block drain plug and radiator drain cock. Refer to MA section ("Changing Engine Coolant", "ENGINE MAINTENANCE"). MT
5. Remove radiator. AT
6. Remove air duct to intake manifold. AT
7. Remove drive belts and water pump pulley. AT
8. Remove alternator and power steering pump. AT
9. Disconnect the following parts:
 - Vacuum hoses FA
 - Fuel hoses FA
 - Wires RA
 - Harness RA
 - Connectors RA
10. Remove all spark plugs. BR

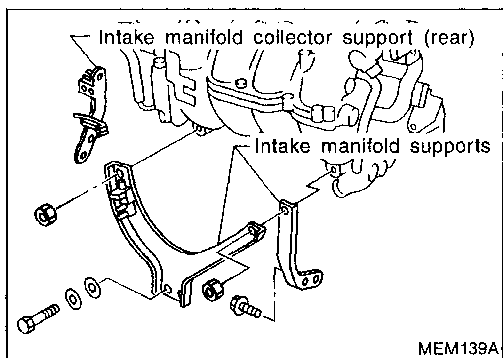
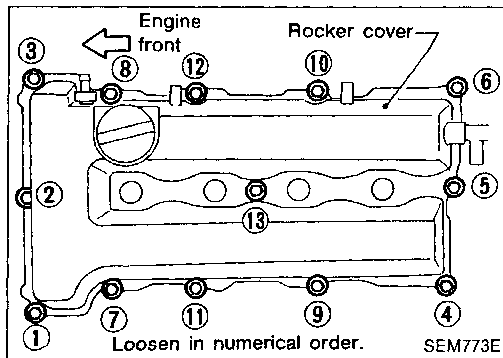

11. Remove rocker cover and oil separator. ST

12. Remove intake manifold supports. RS

TIMING CHAIN

Removal (Cont'd)

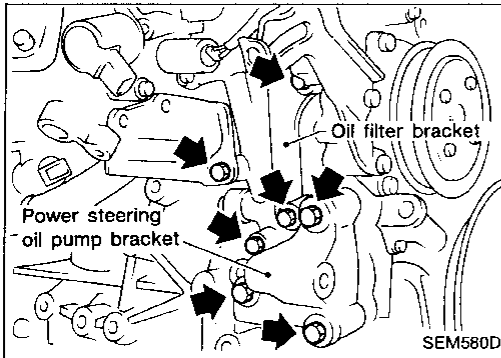

13. Remove oil filter bracket and power steering oil pump bracket.

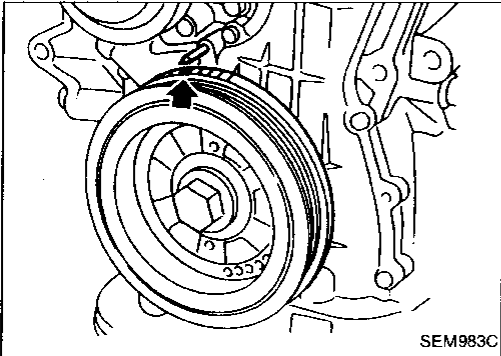

14. Set No. 1 piston at TDC on the compression stroke by rotating crankshaft.

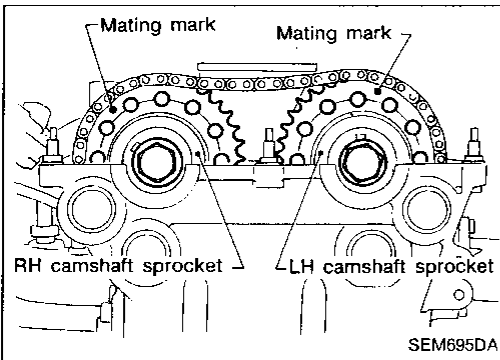

- Rotate crankshaft until mating mark on camshaft sprocket is set at position indicated in figure at left.

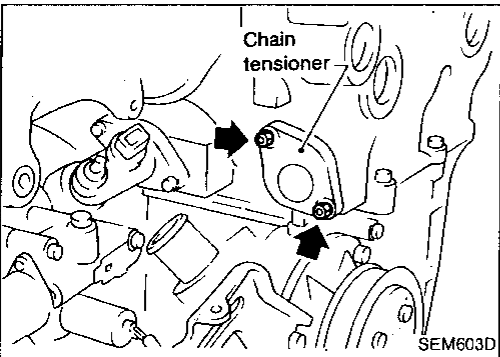

15. Remove chain tensioner.

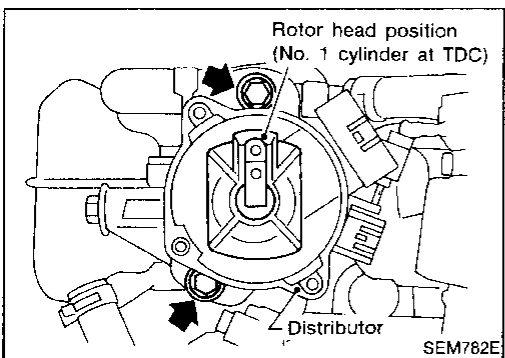

16. Remove distributor.
Do not turn rotor with distributor removed.

TIMING CHAIN

Removal (Cont'd)

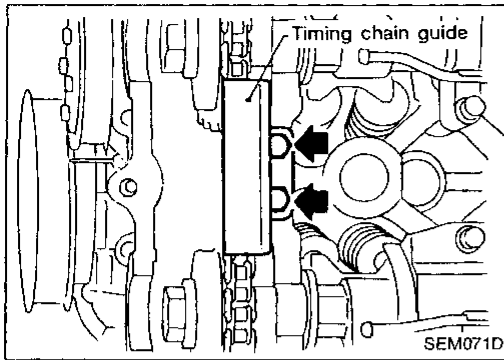

17. Remove timing chain guide.

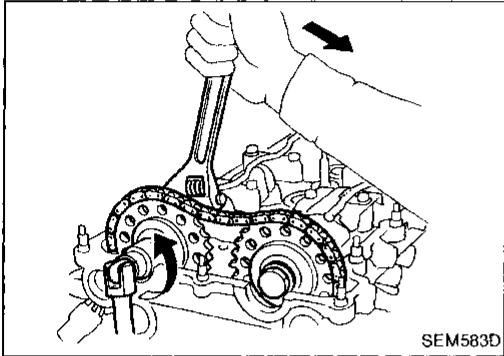

18. Remove camshaft sprockets.

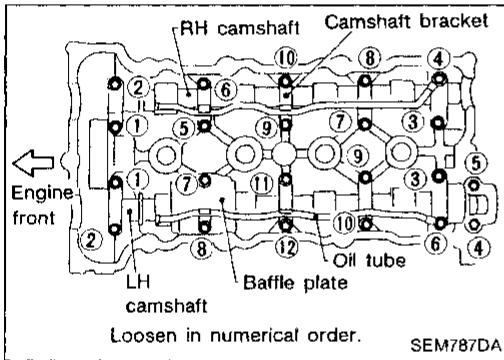

19. Remove camshafts, camshaft brackets, oil tubes and baffle plate.

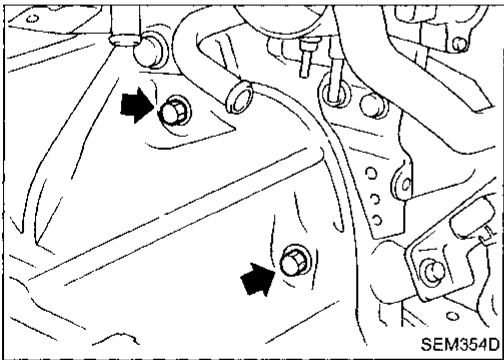

20. Remove starter motor.

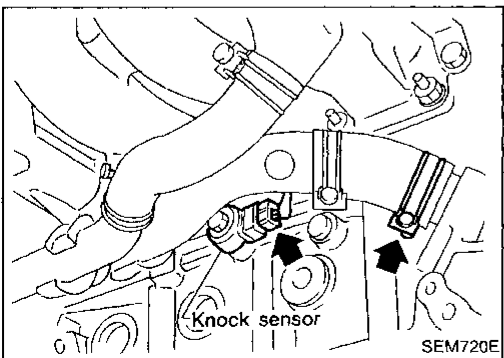

21. Remove the following water hoses.

- Water hose for cylinder block.
- Water hoses from heater.

22. Remove knock sensor harness connector.

GI

MA

EM

LC

EC

FE

CL

MT

AT

FA

RA

BR

ST

RS

BT

HA

EL

IDX

TIMING CHAIN

Removal (Cont'd)

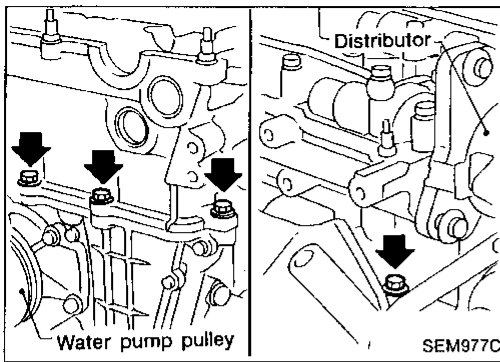

23. Remove cylinder head outside bolts.

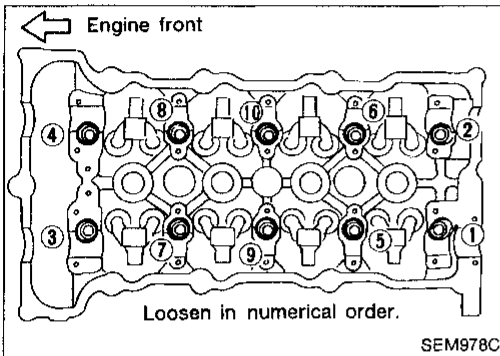

24. Remove cylinder head bolts.

● **Bolts should be loosened in two or three steps.**

25. Remove cylinder head completely with intake and exhaust manifolds.

26. Remove oil pans.

Refer to "Removal" in "OIL PAN" (EM-11).

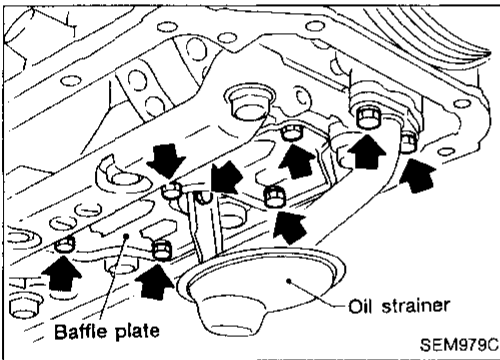

27. Remove oil strainer and baffle plate.

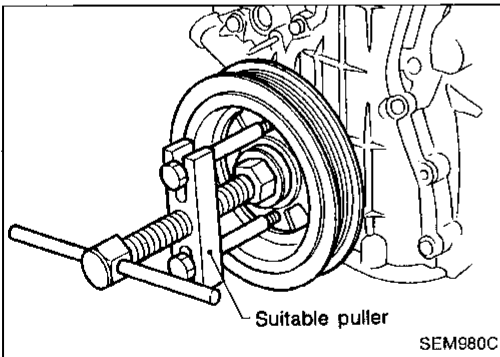

28. Remove crankshaft pulley.

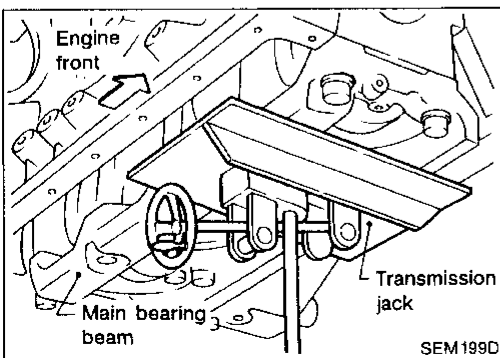

29. Set a suitable transmission jack under main bearing beam.

TIMING CHAIN

Removal (Cont'd)

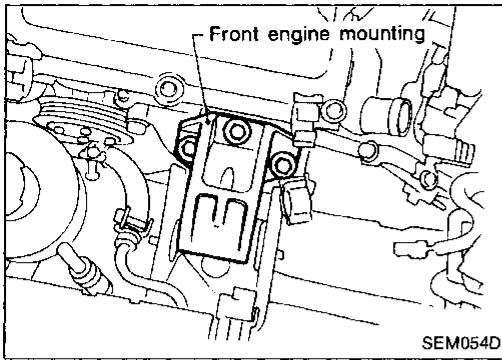

30. Remove front engine mounting.

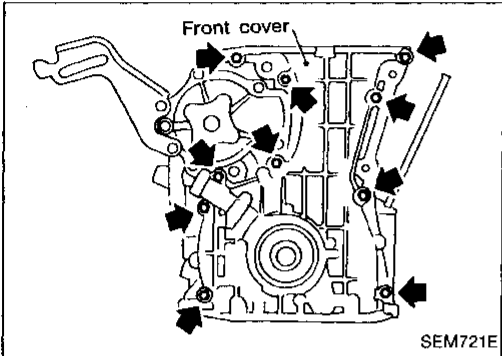

31. Remove front cover.

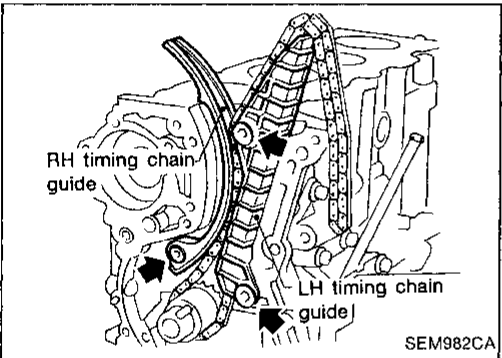

32. Remove timing chain guides and timing chain.

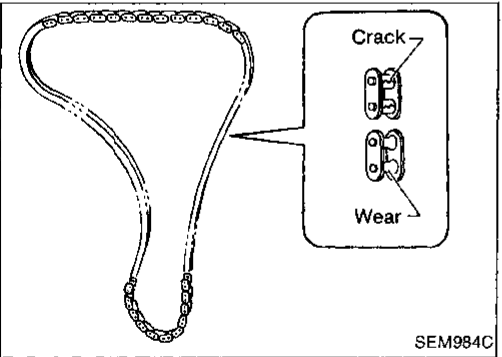

Inspection

Check for cracks and excessive wear at roller links. Replace chain if necessary.

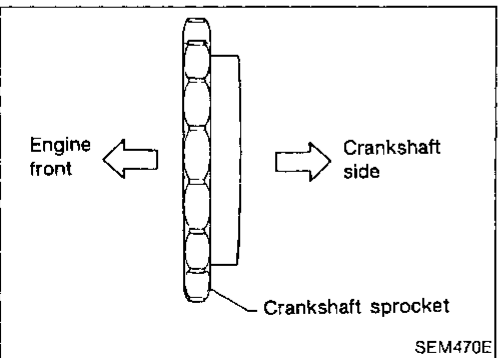

Installation

1. Install crankshaft sprocket on crankshaft.

GI

MA

EM

LC

EC

FE

CL

MT

AT

FA

RA

BR

ST

RS

BT

HA

EL

IDX

TIMING CHAIN

Installation (Cont'd)

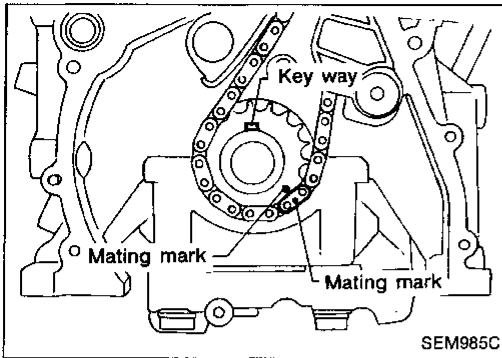

2. Position crankshaft so that No. 1 piston is set at TDC (Key way at 12 o'clock, and mating mark at 4 o'clock approximately). Fit timing chain to crankshaft sprocket, with its mating mark in line with crankshaft sprocket mating mark.

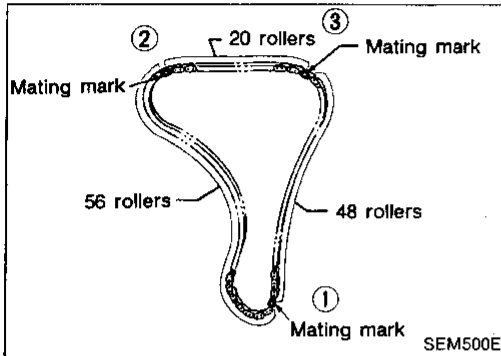

- Mating mark color on timing chain.

- ① : Gold
- ②, ③ : Silver

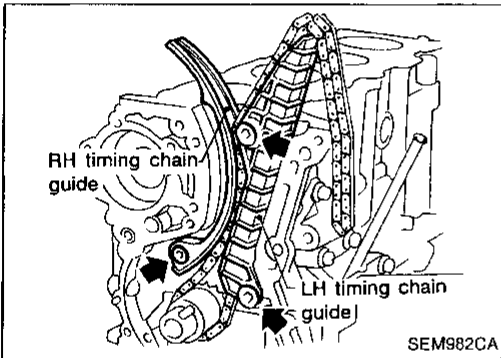

3. Install timing chain and timing chain guides.

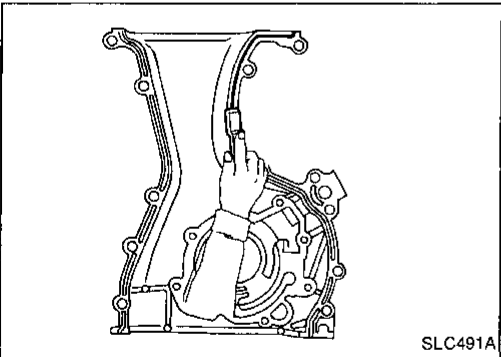

4. Before installing front cover, remove all traces of liquid gasket from mating surface using a scraper.
- Also remove traces of liquid gasket from mating surface of cylinder block.

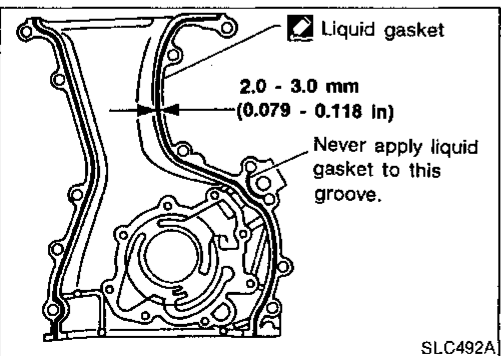

5. Apply a continuous bead of liquid gasket to mating surface of front cover.
- Use Genuine Liquid Gasket or equivalent.