

# FRONT AXLE & FRONT SUSPENSION

## SECTION **FA**

GI

MA

EM

LC

EC

FE

CL

MT

AT

**FA**

RA

BR

ST

RS

BT

HA

EL

IDX

## CONTENTS

<b>PRECAUTIONS AND PREPARATION</b> .....	2	Drive Shaft.....	8
Precautions.....	2	<b>FRONT AXLE</b> .....	9
Special Service Tools.....	2	Wheel Hub and Knuckle.....	9
Commercial Service Tools.....	3	Drive Shaft.....	13
<b>NOISE, VIBRATION AND HARSHNESS (NVH)</b>		<b>FRONT SUSPENSION</b> .....	21
<b>TROUBLESHOOTING</b> .....	4	Components.....	21
NVH Troubleshooting Chart.....	4	Coil Spring and Strut Assembly.....	22
<b>FRONT SUSPENSION SYSTEM</b> .....	5	Stabilizer Bar.....	23
Components.....	5	Transverse Link and Lower Ball Joint.....	24
<b>ON-VEHICLE SERVICE</b> .....	6	<b>SERVICE DATA AND SPECIFICATIONS (SDS)</b> .....	26
Front Axle and Front Suspension Parts.....	6	General Specifications.....	26
Front Wheel Bearing.....	7	Inspection and Adjustment.....	26
Front Wheel Alignment.....	7		

## PRECAUTIONS AND PREPARATION

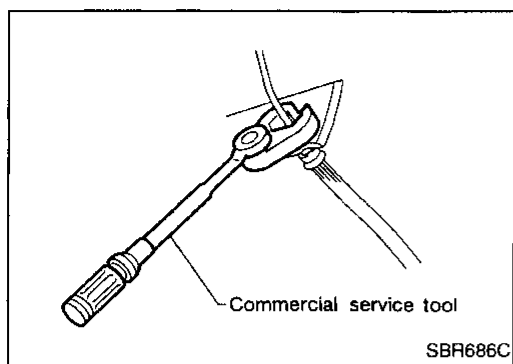

### Precautions

- When installing rubber parts, final tightening must be carried out under unladen condition\* with tires on ground.
- \*: Fuel, radiator coolant and engine oil full. Spare tire, jack, hand tools and mats in designated positions.
- After installing removed suspension parts, check wheel alignment and adjust if necessary.
- Use flare nut wrench when removing or installing brake tubes.
- Always torque brake lines when installing.

### Special Service Tools

The actual shapes of Kent-Moore tools may differ from those of special service tools illustrated here.

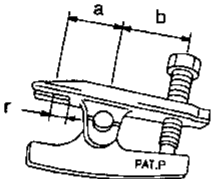
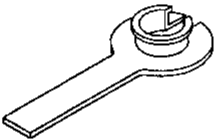
Tool number (Kent-Moore No.) Tool name	Description
HT72520000 (J25730-A) Ball joint remover	<div style="display: flex; align-items: center;">  <div style="margin-left: 20px;"> <p>Removing tie-rod outer end and lower ball joint</p> <p>a: 33 mm (1.30 in) b: 50 mm (1.97 in) r: R11.5 mm (0.453 in)</p> </div> </div> <p style="margin-top: 10px;">NT546</p>
KV38106700 (J34296) KV38106800 (J34297) Differential side oil seal protector	<div style="display: flex; align-items: center;">  <div style="margin-left: 20px;"> <p>Installing drive shaft</p> <p>LH: KV38106700 RH: KV38106800</p> </div> </div> <p style="margin-top: 10px;">NT147</p>

# PRECAUTIONS AND PREPARATION

## Commercial Service Tools

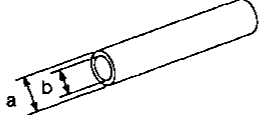
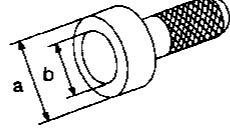
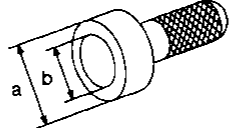
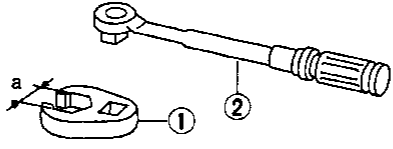
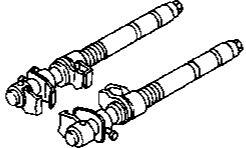
Tool name	Description	
Front wheel hub drift	 <p style="text-align: center;">NT065</p> <p style="text-align: right;">Removing wheel hub</p> <p style="text-align: right;">a: 42 mm (1.65 in) dia. b: 33 mm (1.30 in) dia.</p>	GI MA
Front wheel bearing outer race drift	 <p style="text-align: center;">NT115</p> <p style="text-align: right;">Removing and installing wheel bearing outer race</p> <p style="text-align: right;">a: 76 mm (2.99 in) dia. b: 72 mm (2.83 in) dia.</p>	EM LC
Grease seal drift	 <p style="text-align: center;">NT115</p> <p style="text-align: right;">Installing outer grease seal</p> <p style="text-align: right;">a: 81 mm (3.19 in) dia. b: 76 mm (2.99 in) dia.</p>	EC FE CL
<p>① Flare nut crowfoot</p> <p>② Torque wrench</p>	 <p style="text-align: center;">NT360</p> <p style="text-align: right;">Removing and installing brake piping</p> <p style="text-align: right;">a: 10 mm (0.39 in)</p>	MT AT
Spring compressor	 <p style="text-align: center;">NT717</p> <p style="text-align: right;">Removing and installing coil spring</p>	<div style="background-color: black; color: white; padding: 2px; text-align: center; font-weight: bold;">FA</div> RA BR

GI  
MA  
EM  
LC  
EC  
FE  
CL  
MT  
AT  
FA  
RA  
BR  
ST  
RS  
BT  
HA  
EL  
IDX

# NOISE, VIBRATION AND HARSHNESS (NVH) TROUBLESHOOTING

## NVH Troubleshooting Chart

Use the chart below to help you find cause of the symptom. If necessary, repair or replace these parts.

Symptom		Possible cause and SUSPECTED PARTS		Reference page		Possible cause and SUSPECTED PARTS																					
						Excessive joint angle	Joint sliding resistance	Imbalance	Improper installation, looseness	Shock absorber deformation, damage or deflection	Bushing or mounting deterioration	Parts interference	Spring fatigue	Suspension looseness	Incorrect wheel alignment	Stabilizer bar fatigue	Wheel bearing damage	Out-of-round	Incorrect air pressure	Uneven tire wear	Deformation or damage	Non-uniformity	Incorrect tire size	DRIVE SHAFT	FRONT AXLE AND FRONT SUSPENSION	TIRES	ROAD WHEEL
DRIVE SHAFT	Noise, Vibration	X	X																		X	X	X	X	X	X	X
	Shake	X		X																	X	X	X	X	X	X	X
FRONT AXLE AND FRONT SUSPENSION	Noise				X	X	X	X	X	X											X		X	X	X	X	X
	Shake				X	X	X	X		X											X		X	X	X	X	X
	Vibration				X	X	X	X	X												X		X		X		X
	Shimmy				X	X	X	X			X												X	X	X	X	X
	Judder				X	X	X																X	X	X	X	X
	Poor quality ride or handling				X	X	X	X	X		X	X	X										X	X	X		
TIRES	Noise			X	X								X	X	X	X	X			X	X	X	X	X	X	X	
	Shake			X	X								X	X	X	X	X			X	X	X	X	X	X	X	
	Vibration												X							X	X	X		X		X	
	Shimmy			X	X								X	X	X	X	X			X	X	X	X	X	X	X	
	Judder			X	X								X	X	X	X	X			X	X	X	X	X	X	X	
	Poor quality ride or handling			X	X								X	X	X	X	X			X	X	X	X	X			
ROAD WHEEL	Noise			X	X								X							X	X	X	X	X	X	X	
	Shake			X	X								X							X	X	X	X	X	X	X	
	Shimmy, Judder			X	X								X							X	X	X	X	X	X	X	
	Poor quality ride or handling			X	X								X							X	X	X	X				

X: Applicable

# FRONT SUSPENSION SYSTEM

## Components

SEC. 391-400-401

When installing rubber parts, final tightening must be carried out under unladen condition \*with tires on ground.  
 \* Fuel, radiator coolant and engine oil full. Spare tier, jack, hand tools and masts in designated positions.

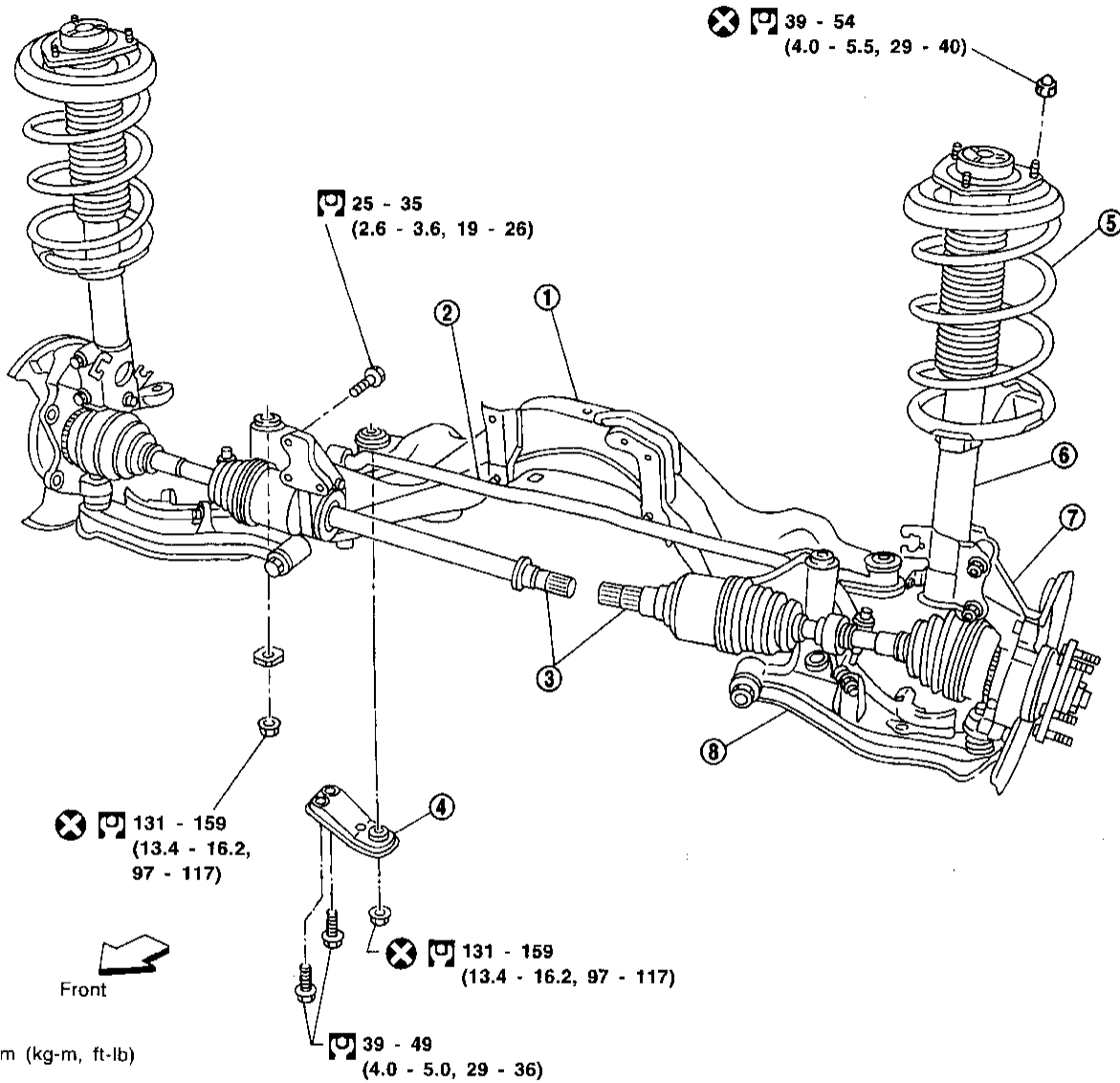

SFA925B

- ① Suspension member
- ② Stabilizer bar
- ③ Drive shaft

- ④ Rebound stopper
- ⑤ Coil spring
- ⑥ Strut assembly

- ⑦ Knuckle
- ⑧ Transverse link

GI

MA

EM

LC

EC

FE

CL

MT

AT

FA

RA

BR

ST

RS

BT

HA

EL

IDX

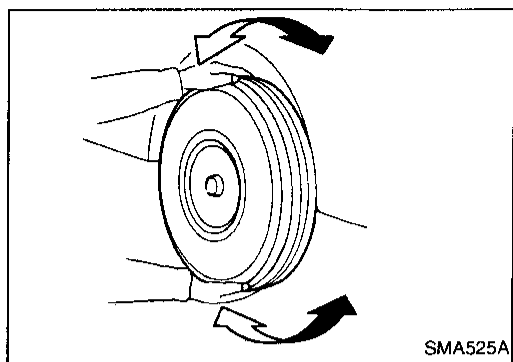

## Front Axle and Front Suspension Parts

Check front axle and front suspension parts for looseness, cracks, wear or other damage.

- Shake each front wheel to check for excessive play.
- Make sure that cotter pins are inserted.
- Retighten all axle and suspension nuts and bolts to the specified torque.

**Tightening torque:**

**Refer to FRONT SUSPENSION (FA-21).**

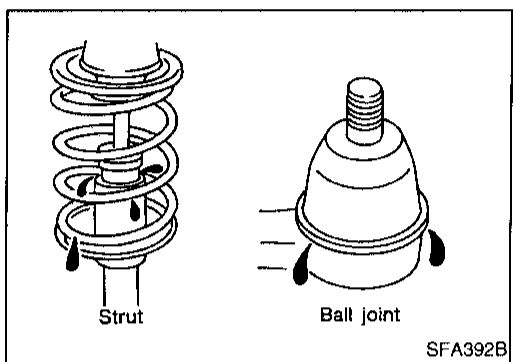

- Check strut (shock absorber) for oil leakage or other damage.
- Check suspension ball joint for grease leakage and ball joint dust cover for cracks or other damage. If ball joint dust cover is cracked or damaged, replace transverse link.

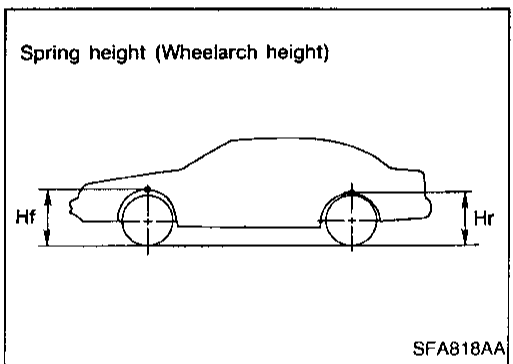

- Check spring height from top of wheelarch to the ground.
- (1) Vehicle must be unladen\*, parked on a level surface, and tires checked for proper inflation and wear (tread wear indicator must not be showing).
    - \*: Fuel, radiator coolant and engine oil full. Spare tire, jack, hand tools and mats in designated positions.
  - (2) Bounce vehicle up and down several times before measuring.
    - Standard height: Refer to SDS (FA-27).**
  - (3) Spring height is not adjustable. If out of specification, check for worn springs or suspension parts.

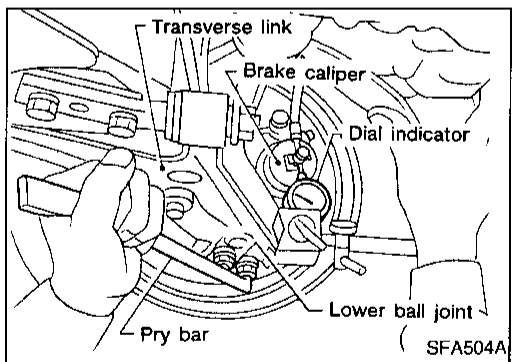

- Check suspension ball joint end play.
- (1) Jack up front of vehicle and set the stands.
  - (2) Clamp dial indicator onto transverse link and place indicator tip on lower edge of brake caliper.
  - (3) Make sure front wheels are straight and brake pedal is depressed.
  - (4) Place a pry bar between transverse link and inner rim of road wheel.
  - (5) While raising and releasing pry bar, observe maximum dial indicator value.
    - Vertical end play: 0 mm (0 in)**
  - (6) If ball joint movement is beyond specifications, remove and replace it.

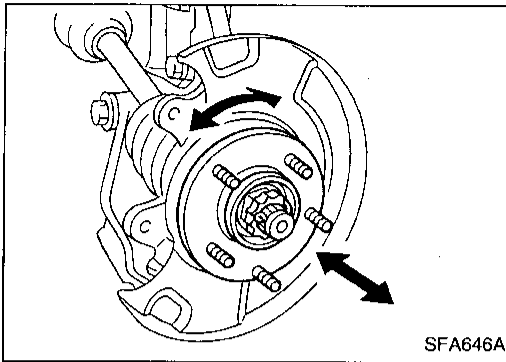

## Front Wheel Bearing

- Check that wheel bearings operate smoothly.
- Check axial end play.  
**Axial end play: 0.05 mm (0.0020 in) or less**
- If out of specification or wheel bearing does not turn smoothly, replace wheel bearing assembly.  
Refer to FRONT AXLE — Wheel Hub and Knuckle (FA-9).

GI

MA

EM

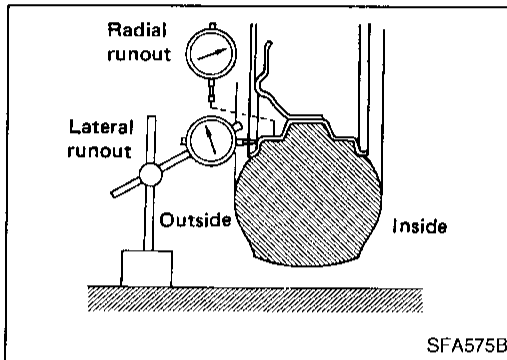

## Front Wheel Alignment

Before checking front wheel alignment, be sure to make a preliminary inspection (Unladen\*).

\*: Fuel, radiator coolant and engine oil full. Spare tire, jack, hand tools and mats in designated positions.

LC

EC

FE

CL

## PRELIMINARY INSPECTION

1. Check tires for wear and improper inflation.
2. Check wheel runout.  
**Wheel runout:**  
**Refer to SDS (FA-27).**
3. Check front wheel bearings for looseness.
4. Check front suspension for looseness.
5. Check steering linkage for looseness.
6. Check that front shock absorbers work properly.
7. Check vehicle posture (Unladen).

MT

AT

FA

RA

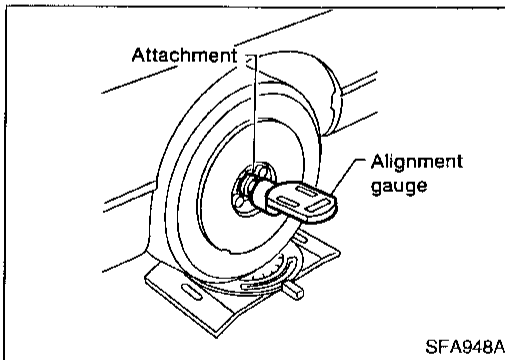

## CAMBER, CASTER AND KINGPIN INCLINATION

**Camber, caster and kingpin inclination are preset at factory and cannot be adjusted.**

1. Measure camber, caster and kingpin inclination of both right and left wheels with a suitable alignment gauge.

**Camber, Caster and Kingpin inclination:**  
**Refer to SDS (FA-26).**

2. If camber, caster or kingpin inclination is not within specification, inspect front suspension parts. Replace damaged or worn out parts.

BR

ST

RS

BT

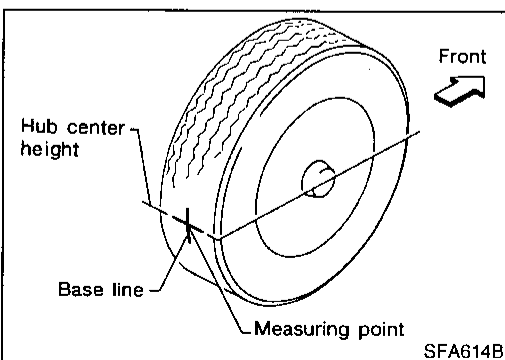

## TOE-IN

Measure toe-in using following procedure.

### WARNING:

- Perform following procedure always on a flat surface.
  - Make sure that no person is in front of the vehicle before pushing it.
1. Move front of vehicle up and down to stabilize the posture.
  2. Push the vehicle straight ahead about 5 m (196.9 in).
  3. Put a mark on base line of the tread (rear side) at the same height of hub center to be a measuring point.

HA

EL

IDX

## ON-VEHICLE SERVICE

### Front Wheel Alignment (Cont'd)

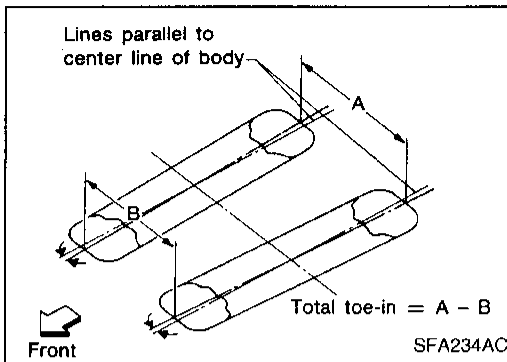

4. Measure distance "A" (rear side).
5. Push the vehicle slowly ahead to turn the wheels around 180 degrees.

If the wheels have passed 180 degrees, try the above procedure again from the beginning. Never push vehicle backward.

6. Measure distance "B" (front side).

**Total toe-in:**

**Refer to SDS (FA-26).**

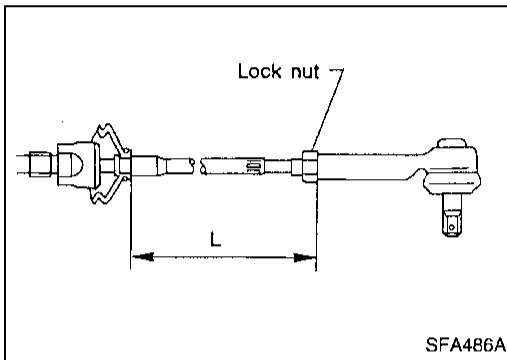

7. Adjust toe-in by varying the length of steering tie-rods.

(1) Loosen lock nuts.

(2) Adjust toe-in by screwing tie-rods in and out.

**Standard length "L":**

**Refer to ST section.**

(3) Tighten lock nuts to specified torque.

**Lock nut tightening torque:**

**Refer to ST section.**

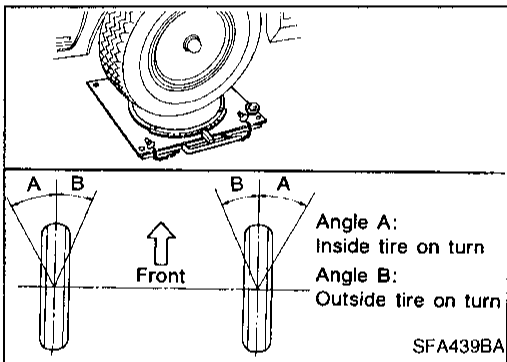

### FRONT WHEEL TURNING ANGLE

1. Set wheels in straight-ahead position. Then move vehicle forward until front wheels rest on turning radius gauge properly.
2. Rotate steering wheel all the way right and left; measure turning angle.

**Do not hold the steering wheel on full lock for more than 15 seconds.**

**Wheel turning angle (Full turn): Refer to SDS (FA-26).**

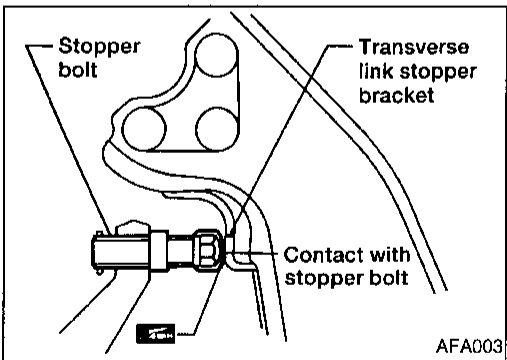

3. Check stopper bolt head to see whether it contacts stopper bracket at specified outside wheel angle. If not, adjust stopper bolt to contact stopper bracket at the correct angle.

Adjust protrusion of stopper bolt before placing stopper bolt cap.

Apply grease to face of stopper bracket that bolt touches.

**Tighten stopper bolt lock nut.**

**Ⓜ: 54 - 72 N·m (5.5 - 7.3 kg·m, 40 - 53 ft·lb)**

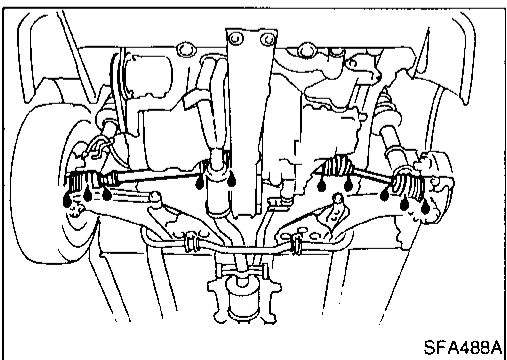

### Drive Shaft

- Check for grease leakage or other damage.



# FRONT AXLE

SEC. 400

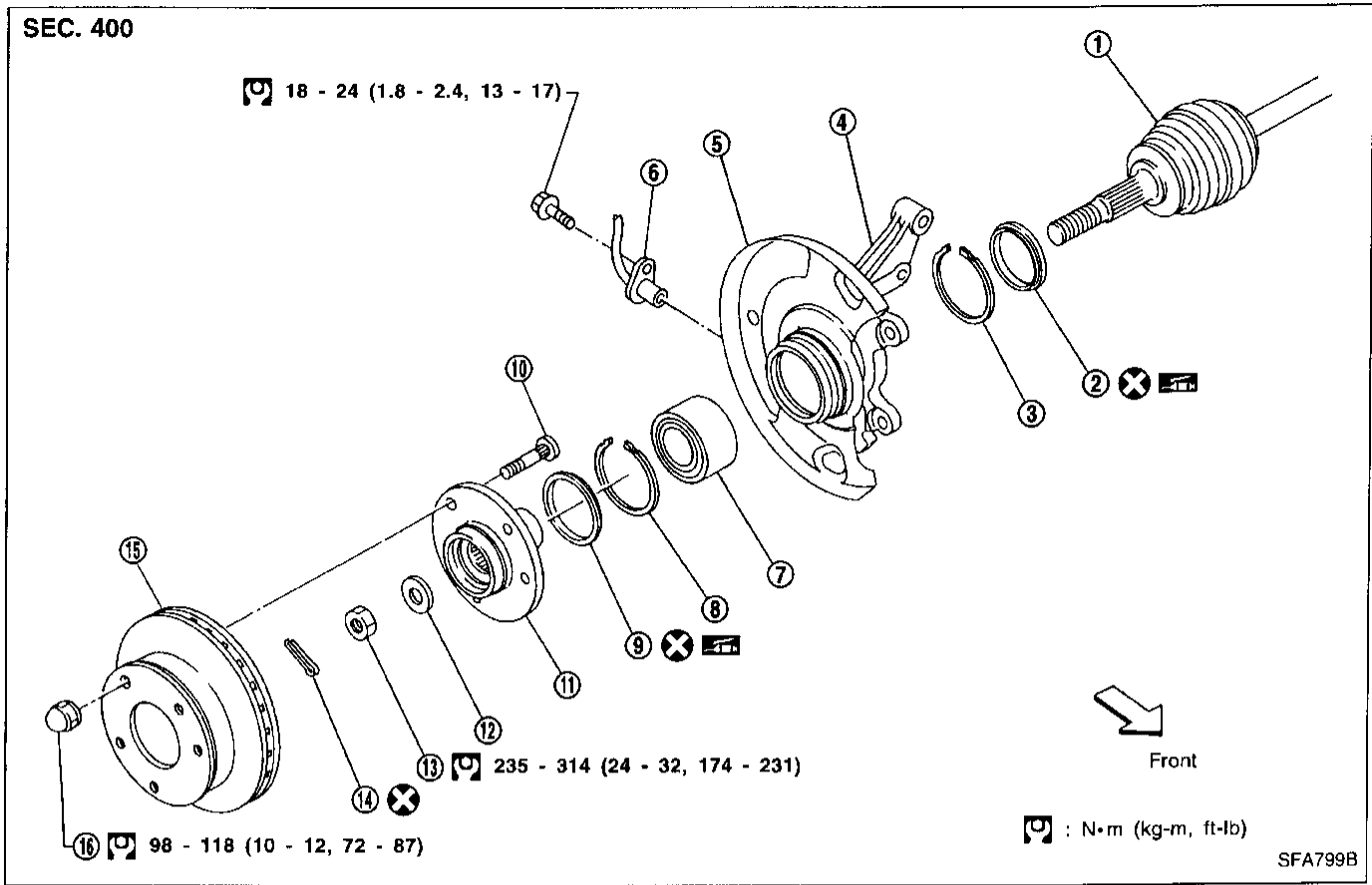

- |                     |                          |                          |
|---------------------|--------------------------|--------------------------|
| ① Drive shaft       | ⑦ Wheel bearing assembly | ⑫ Plain washer           |
| ② Inner grease seal | ⑧ Snap ring              | ⑬ Wheel bearing lock nut |
| ③ Snap ring         | ⑨ Outer grease seal      | ⑭ Cotter pin             |
| ④ Knuckle           | ⑩ Hub bolt               | ⑮ Disc rotor             |
| ⑤ Baffle plate      | ⑪ Wheel hub              | ⑯ Wheel nut              |
| ⑥ ABS sensor        |                          |                          |

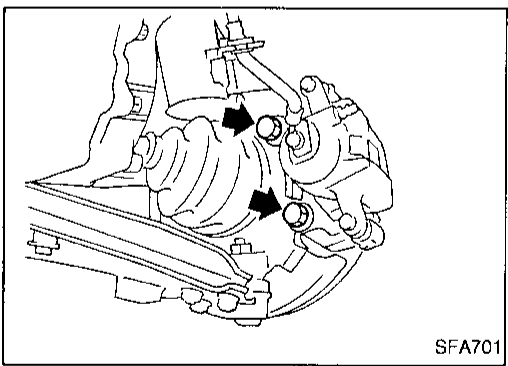

## Wheel Hub and Knuckle

### REMOVAL

**CAUTION:**  
 Before removing the front axle assembly, disconnect the ABS wheel sensor from the assembly. Then move it away from the front axle assembly area. Failure to do so may result in damage to the sensor wires and the sensor becoming inoperative.

- Remove wheel bearing lock nut.
- Remove brake caliper assembly and rotor.

In this case, suspend caliper assembly with wire so as not to stretch brake hose.  
 Be careful not to depress brake pedal, or piston will pop out.  
 Make sure brake hose is not twisted.

GI  
 MA  
 EM  
 LC  
 EC  
 FE  
 CL  
 MT  
 AT  
**FA**  
 RA  
 BR  
 ST  
 RS  
 BT  
 HA  
 EL  
 IDX

## FRONT AXLE

### Wheel Hub and Knuckle (Cont'd)

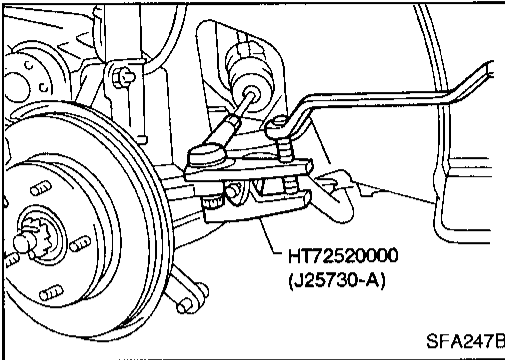

- Remove tie-rod ball joint.

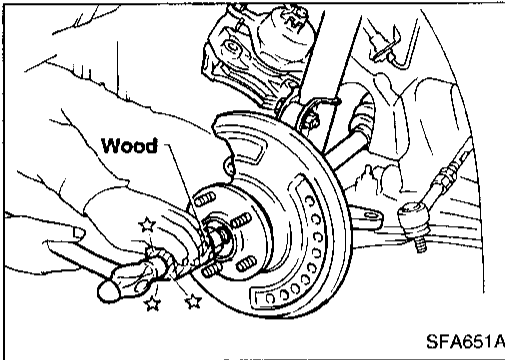

- Separate drive shaft from knuckle by lightly tapping it.  
**Cover boots with shop towel so as not to damage them when removing drive shaft.**

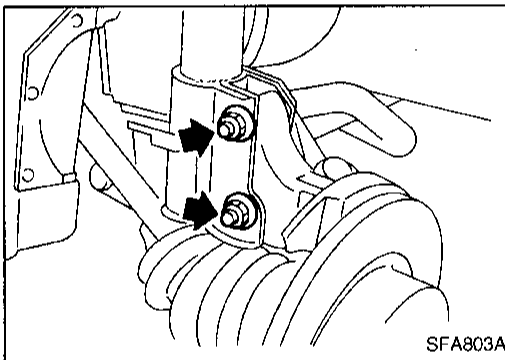

- Remove strut lower mounting bolts.

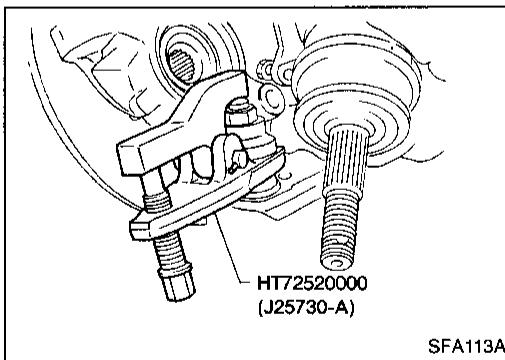

- Loosen lower ball joint tightening nut.
- Separate knuckle from lower ball joint stud with Tool.
- Remove knuckle from transverse link.

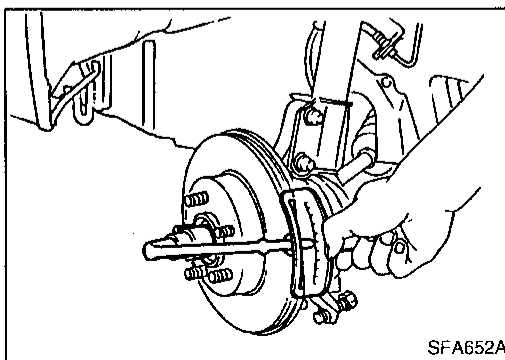

### INSTALLATION

- Install knuckle with wheel hub.  
**When installing knuckle to strut, be sure to hold bolts and tighten nuts.**

: 140 - 159 N·m  
(14.3 - 16.2 kg-m, 103 - 117 ft-lb)

**Before tightening, apply oil to threaded portion of drive shaft and both sides of plain washer.**

- Tighten wheel bearing lock nut.  
: 235 - 314 N·m  
(24 - 32 kg-m, 174 - 231 ft-lb)

## FRONT AXLE

### Wheel Hub and Knuckle (Cont'd)

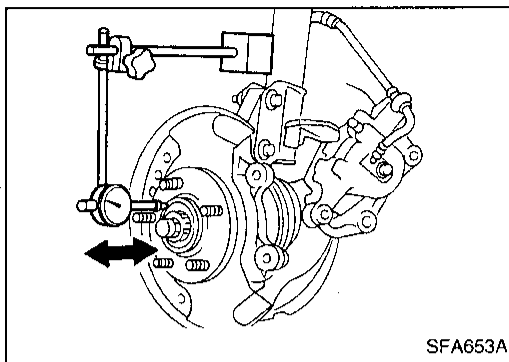

- Check wheel bearing axial end play.  
**Axial end play:**  
0.05 mm (0.0020 in) or less

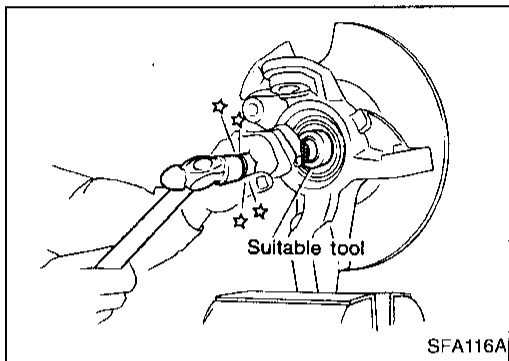

### DISASSEMBLY

#### CAUTION:

When removing wheel hub or wheel bearing from knuckle, replace wheel bearing assembly (outer race, inner races and grease seals) with a new one.

#### Wheel hub

Drive out hub with inner race (outside) from knuckle with a suitable tool.

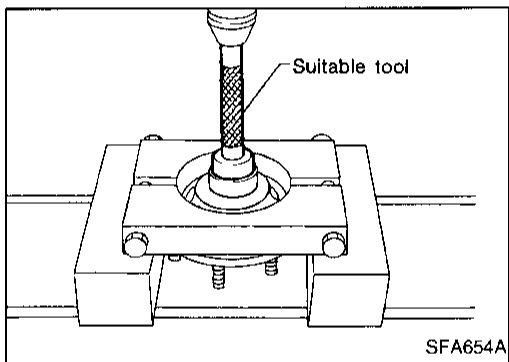

#### Wheel bearing

When replacing wheel bearing, replace wheel bearing assembly (inner races and outer race).

- Remove bearing inner race (outside), then remove outer grease seal.

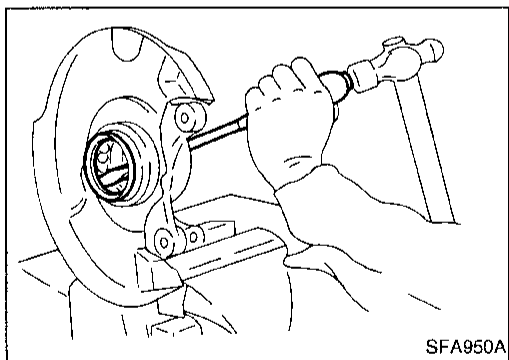

- Remove inner grease seal from knuckle.

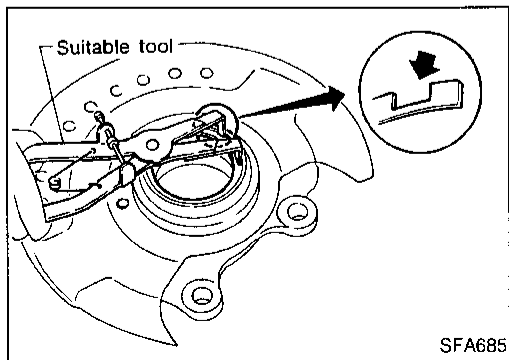

- Remove snap ring.

GI

MA

EM

LC

EC

FE

CL

MT

AT

FA

RA

BR

ST

RS

BT

HA

EL

IDX

## FRONT AXLE

### Wheel Hub and Knuckle (Cont'd)

- Press out bearing outer race.

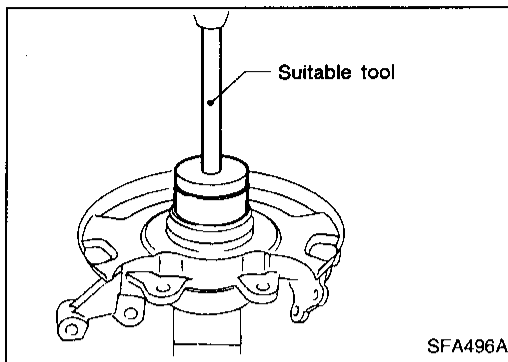

### INSPECTION

#### Wheel hub and knuckle

Check wheel hub and knuckle for cracks by using a magnetic exploration or dyeing test.

#### Snap ring

Check snap ring for wear or cracks. Replace if necessary.

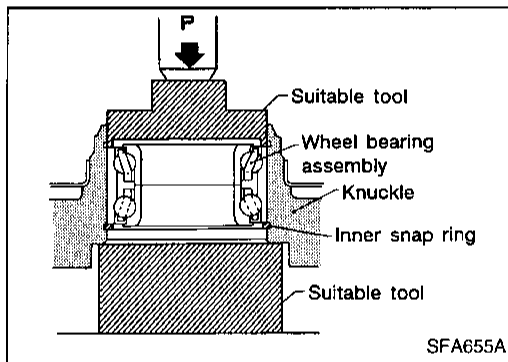

### ASSEMBLY

1. Install inner snap ring into groove of knuckle.
2. Press new wheel bearing assembly into knuckle.

Maximum load P:

29 kN (3 ton, 3.3 US ton, 3.0 Imp ton)

#### CAUTION:

- Do not press inner race of wheel bearing assembly.
- Do not apply oil or grease to mating surfaces of wheel bearing outer race and knuckle.

3. Install outer snap ring into groove of knuckle.

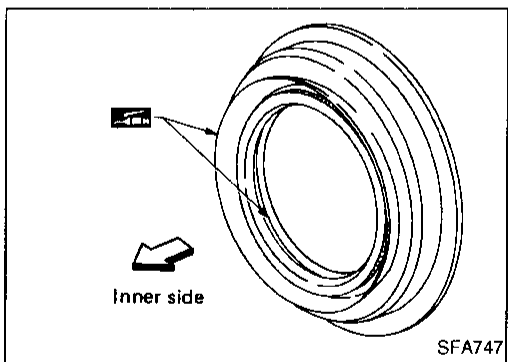

4. Pack grease seal lip with multi-purpose grease.

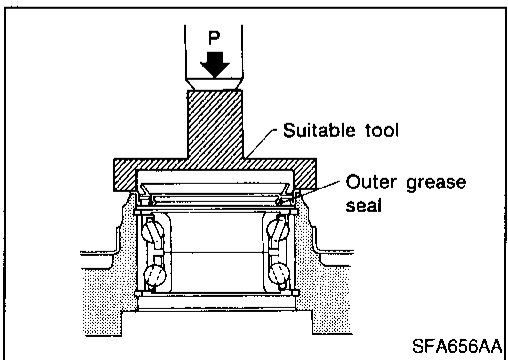

5. Install outer grease seal.

# FRONT AXLE

## Wheel Hub and Knuckle (Cont'd)

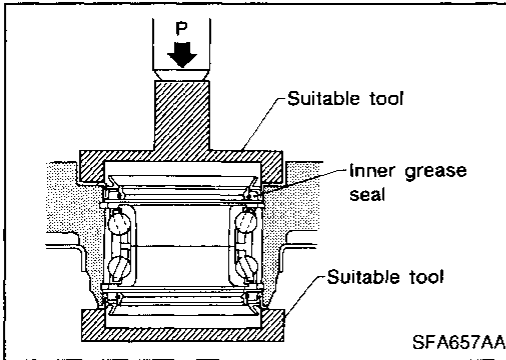

6. Install inner grease seal.

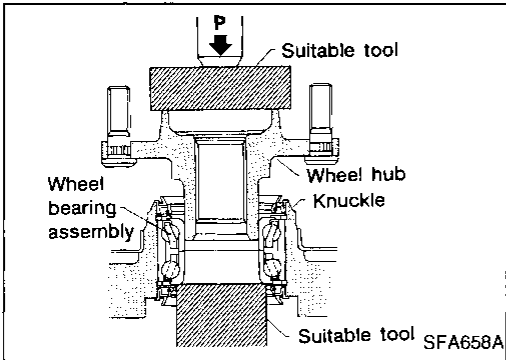

7. Press wheel hub into knuckle.

**Maximum load P:**  
**49 kN (5 ton, 5.5 US ton, 4.9 Imp ton)**  
**Be careful not to damage grease seal.**

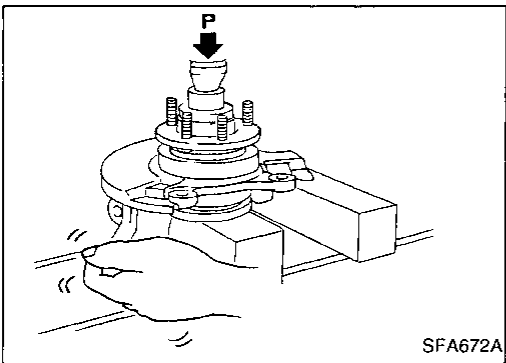

8. Check bearing operation.

(1) Add load P with press.

**Load P:**

**49 kN (5 ton, 5.5 US ton, 4.9 Imp ton)**

(2) Spin knuckle several turns in both directions.

(3) Make sure that wheel bearings operate smoothly.

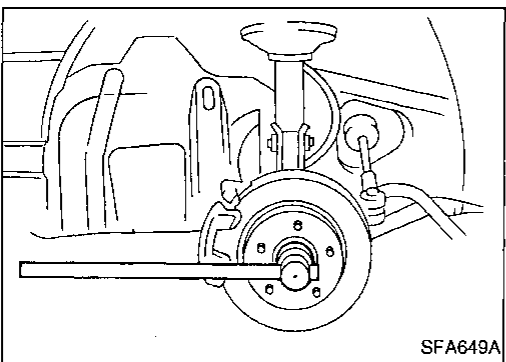

## Drive Shaft

### REMOVAL

- Remove wheel bearing lock nut.

**Brake caliper need not be disconnected.**

**Do not twist or stretch brake hose when moving components.**

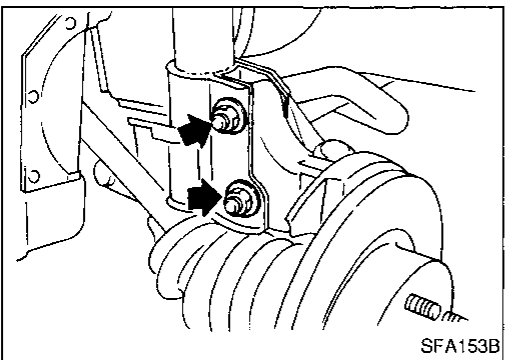

- Remove strut lower mounting bolts.
- Remove brake hose clip.

GI

MA

EM

LC

EC

FE

CL

MT

AT

FA

RA

BR

ST

RS

BT

HA

EL

IDX

## FRONT AXLE

### Drive Shaft (Cont'd)

- Separate drive shaft from knuckle by slightly tapping it.  
**When removing drive shaft, cover boots with shop towel to prevent damage to them.**

Refer to FRONT AXLE — Wheel Hub and Knuckle (FA-9).

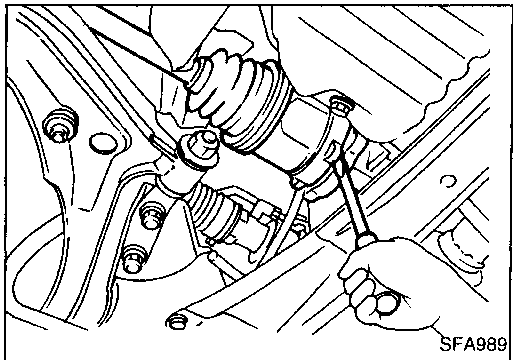
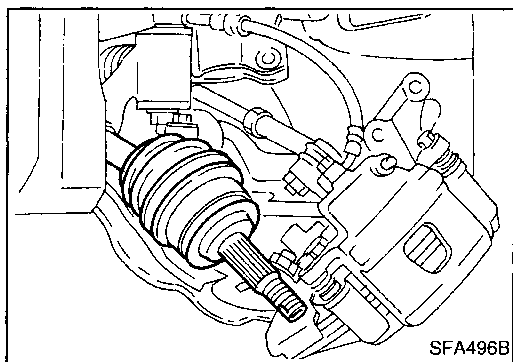

1. Remove right drive shaft from transaxle.

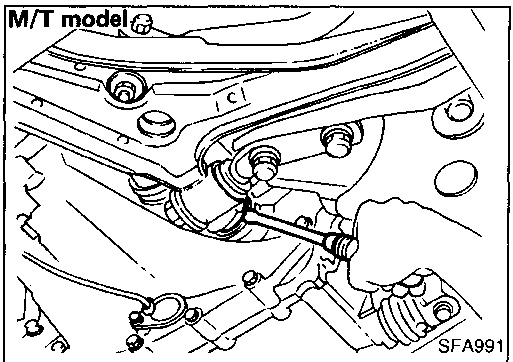

2. Remove left drive shaft from transaxle.

—For M/T models—

- Pry off drive shaft from transaxle as shown at left.

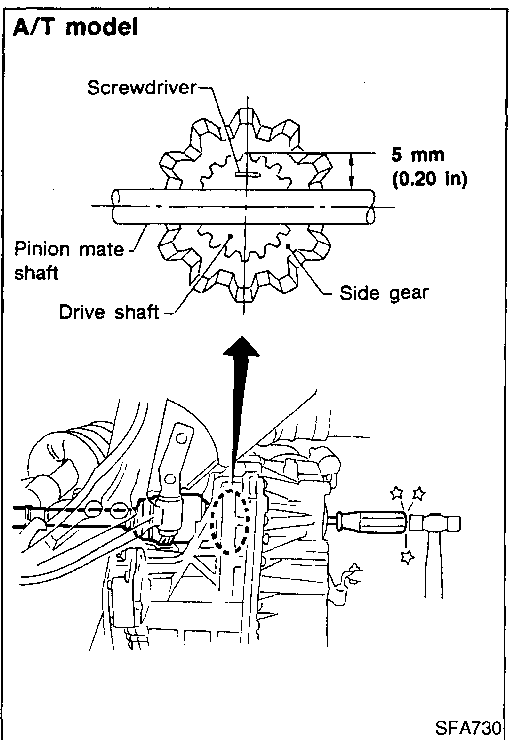

—For A/T models—

- Remove left drive shaft with a suitable tool.  
**Be careful not to damage pinion mate shaft and side gear.**

# FRONT AXLE

## Drive Shaft (Cont'd)

### INSTALLATION

#### Transaxle side

1. Drive a new oil seal to transaxle. Refer to MT or AT section.
2. Set Tool along the inner circumference of oil seal.

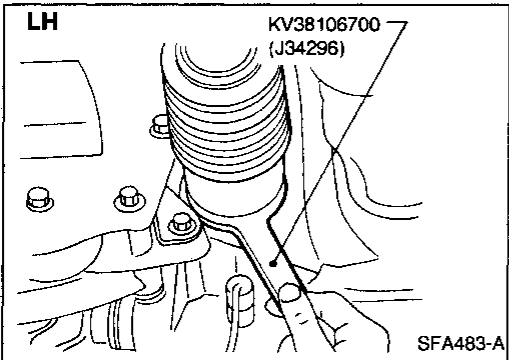
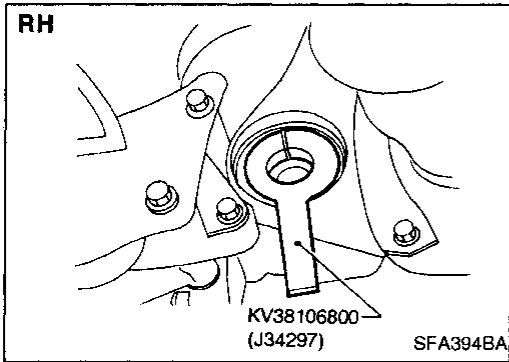

3. Insert drive shaft into transaxle. Be sure to properly align the serrations and then withdraw Tool.
4. Push drive shaft, then press-fit circular clip on the drive shaft into circular clip groove of side gear.
5. After its insertion, try to pull the flange out of the slide joint by hand. If it pulls out, the circular clip is not properly meshed with the side gear.

#### Wheel side

- Install drive shaft into knuckle.
  - Tighten wheel bearing lock nut.
- Refer to FRONT AXLE — Wheel Hub and Knuckle (FA-9).

GI

MA

EM

LC

EC

FE

CL

MT

AT

**FA**

RA

BR

ST

RS

BT

HA

EL

IDX

# FRONT AXLE

## Drive Shaft (Cont'd)

### COMPONENTS

**SEC. 391**

**Circular clip:**  
 Circular clips should be properly meshed with differential side gear (transaxle side) and with joint assembly (wheel side). Make sure they will not come out.  
**Be careful not to damage boots. Use suitable protector or cloth during removal and installation.**

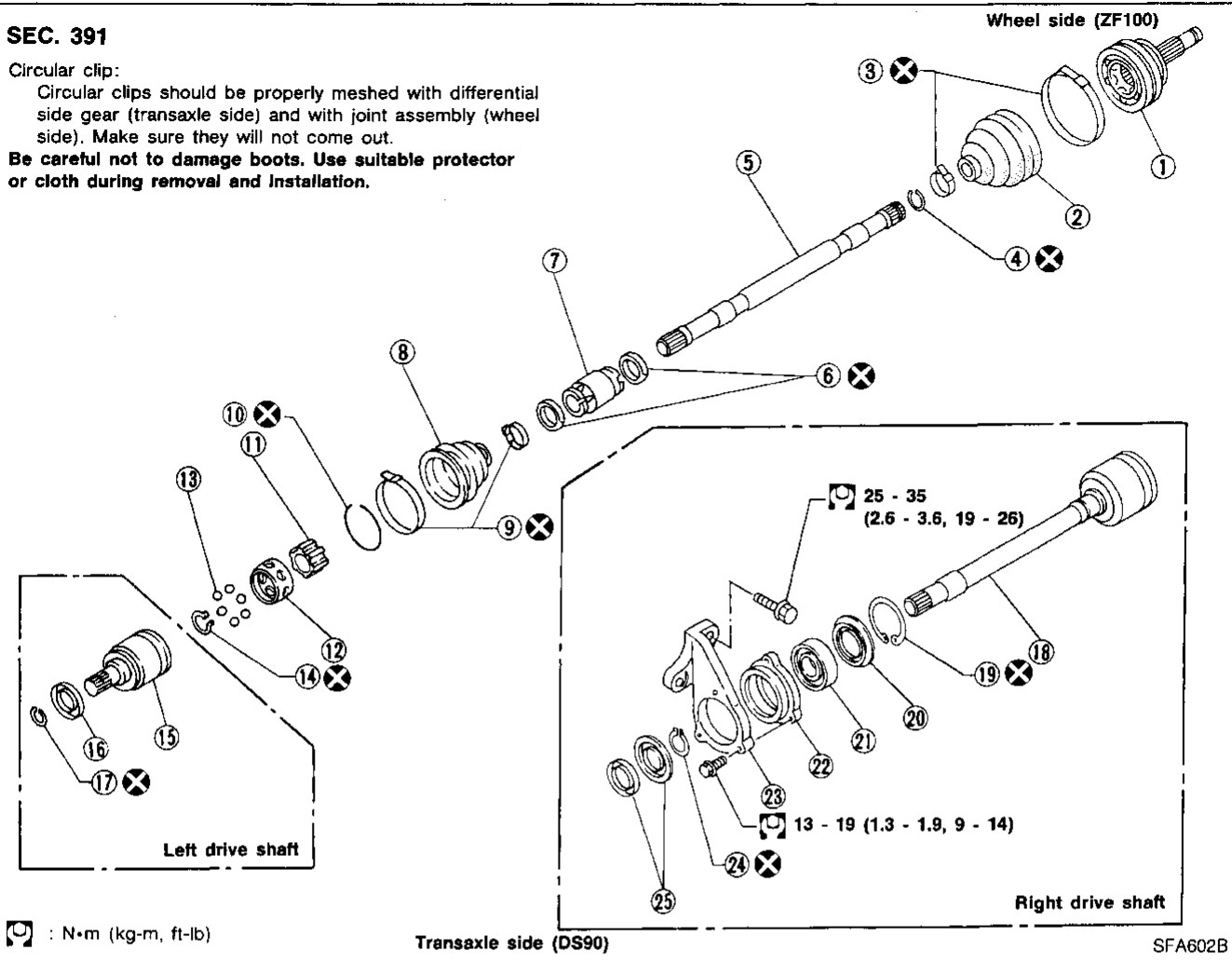

- |                       |  |                            |
|-----------------------|--|----------------------------|
| ① Joint assembly      | ⑩ Snap ring                                | ⑲ Snap ring                |
| ② Boot                | ⑪ Inner race                               | ⑳ Dust shield              |
| ③ Boot band           | ⑫ Cage                                     | ㉑ Support bearing          |
| ④ Circular clip       | ⑬ Ball                                     | ㉒ Support bearing retainer |
| ⑤ Drive shaft         | ⑭ Snap ring                                | ㉓ Bracket                  |
| ⑥ Dynamic damper band | ⑮ Slide joint housing                      | ㉔ Snap ring                |
| ⑦ Dynamic damper      | ⑯ Dust shield                              | ㉕ Dust shield              |
| ⑧ Boot                | ⑰ Circular clip                            |                            |
| ⑨ Boot band           | ⑱ Slide joint housing with extension shaft |                            |

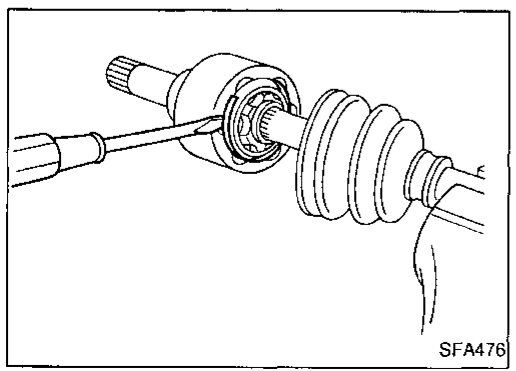

**DISASSEMBLY**

**Transaxle side**

1. Remove boot bands.
2. Put matchmarks on slide joint housing and inner race, before separating joint assembly.
3. Pry off snap ring with a screwdriver, and pull out slide joint housing.



# FRONT AXLE

## Drive Shaft (Cont'd)

4. Put matchmarks on inner race and drive shaft.
5. Pry off snap ring, then remove ball cage, inner race and balls as a unit.
6. Draw out boot.

**Cover drive shaft serrations with tape so as not to damage the boot.**

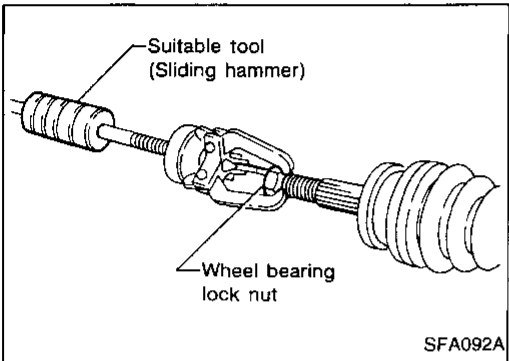
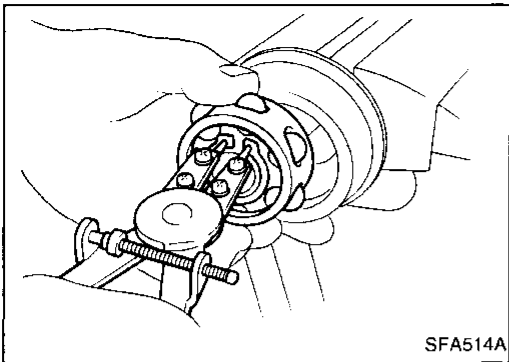

## Wheel side

### CAUTION:

**The joint on the wheel side cannot be disassembled.**

- Before separating joint assembly, put matchmarks on drive shaft and joint assembly.
- Separate joint assembly with a suitable tool.

**Be careful not to damage threads on drive shaft.**

- Remove boot bands.

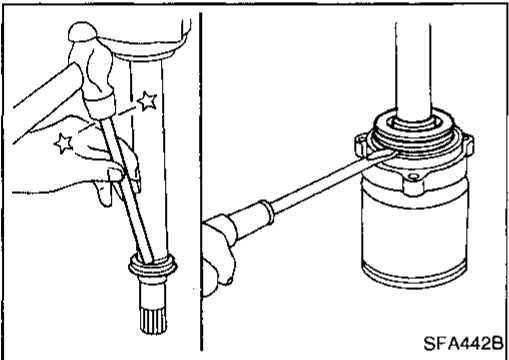

## Support bearing

- Remove dust shield.

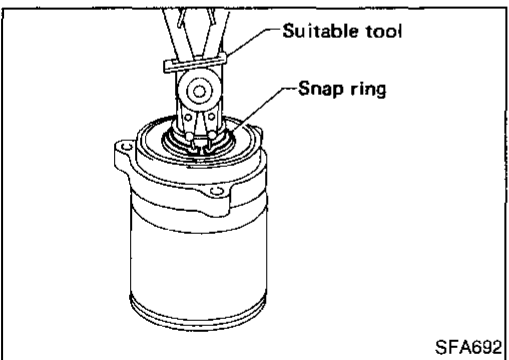

- Pry off snap ring.

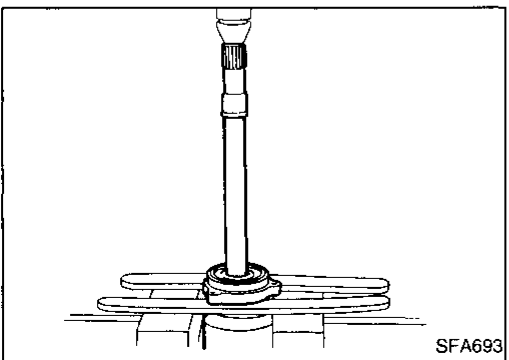

- Press support bearing assembly out of drive shaft.

GI

MA

EM

LC

EC

FE

CL

MT

AT

**FA**

RA

BR

ST

RS

BT

HA

EL

IDX

## FRONT AXLE

### Drive Shaft (Cont'd)

- Press support bearing out of retainer.

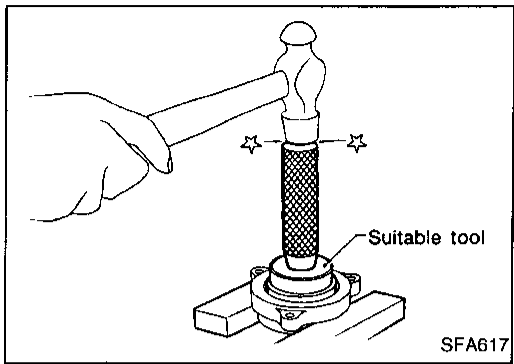

### INSPECTION

Thoroughly clean all parts in cleaning solvent, and dry with compressed air. Check parts for evidence of deformation or other damage.

#### Drive shaft

Replace drive shaft if it is twisted or cracked.

#### Boot

Check boot for fatigue, cracks, or wear. Replace boot with new boot bands.

#### Joint assembly

Replace joint assembly if it is deformed or damaged.

#### Support bearing

Make sure wheel bearing rolls freely and is free from noise, cracks, pitting or wear.

#### Support bearing bracket

Check support bearing bracket for cracks with a magnetic exploration or dyeing test.

### ASSEMBLY

- After drive shaft has been assembled, ensure that it moves smoothly over its entire range without binding.
- Use **NISSAN GENUINE GREASE** or equivalent after every overhaul.

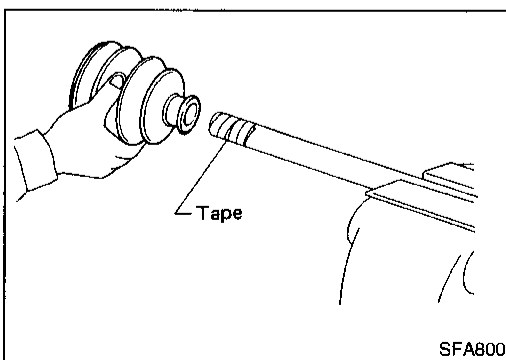

#### Wheel side

1. Install boot and new small boot band on drive shaft.

**Cover drive shaft serration with tape so as not to damage boot during installation.**

# FRONT AXLE

## Drive Shaft (Cont'd)

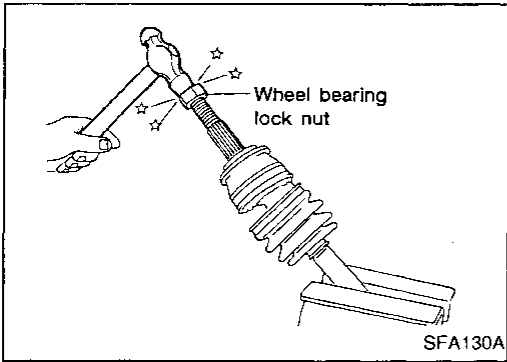

2. Set joint assembly onto drive shaft by lightly tapping it. Install joint assembly securely, ensuring marks which were made during disassembly are properly aligned.

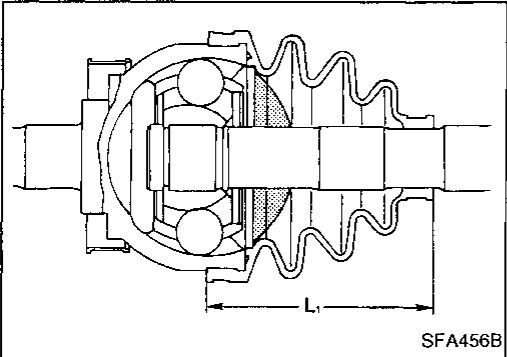

3. Pack drive shaft with specified amount of grease.  
**Specified amount of grease:**  
135 - 145 g (4.76 - 5.11 oz)
4. Make sure that boot is properly installed on the drive shaft groove. Set boot so that it does not swell and deform when its length is "L<sub>1</sub>".  
**Length "L<sub>1</sub>":**  
96 - 98 mm (3.78 - 3.86 in)

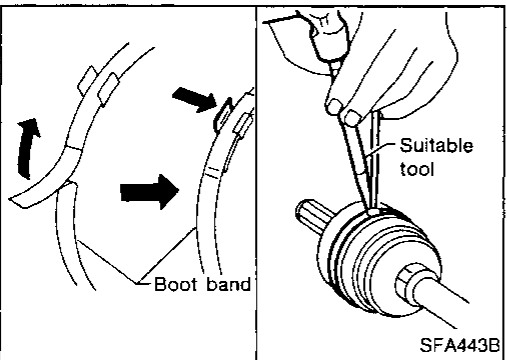

5. Lock new larger and smaller boot bands securely with a suitable tool.

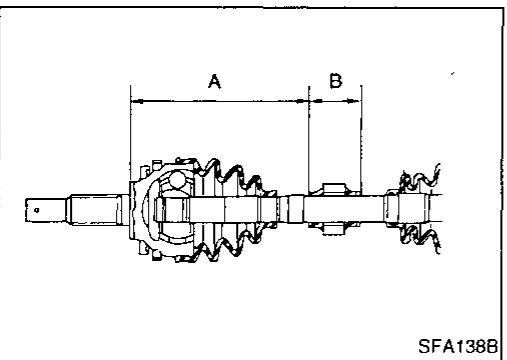

### Dynamic damper

1. Use new damper band when reinstalling.
2. Install dynamic damper from stationary-joint side while holding it securely.

**Length (Left side only):**  
"A": 205 - 215 mm (8.07 - 8.46 in)  
"B": 50 mm (1.97 in)

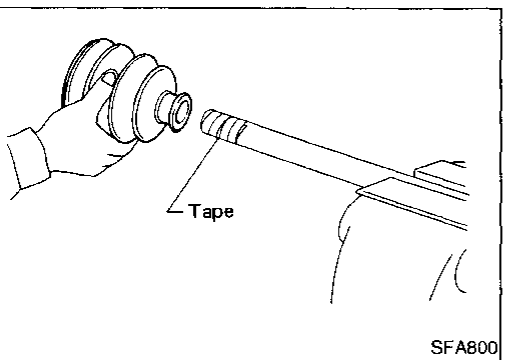

### Transaxle side

1. Install boot and new small boot band on drive shaft.  
**Cover drive shaft serration with tape so as not to damage boot during installation.**

GI

MA

EM

LC

EC

FE

CL

MT

AT

FA

RA

BR

ST

RS

BT

HA

EL

IDX

## FRONT AXLE

### Drive Shaft (Cont'd)

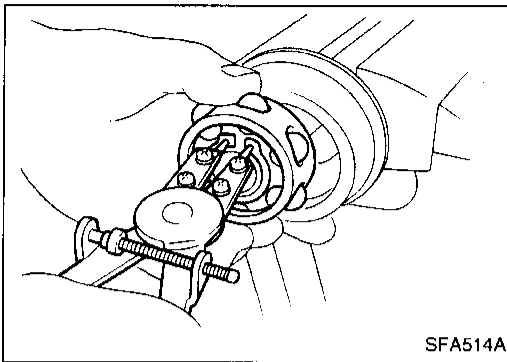

2. Install ball cage, inner race and balls as a unit, making sure the marks which were made during disassembly are properly aligned.
3. Install new snap ring.

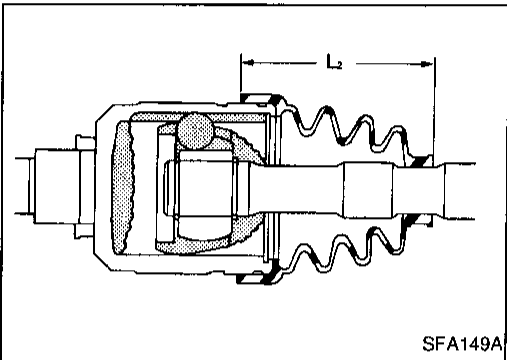

4. Pack drive shaft with specified amount of grease.  
**Specified amount of grease:**  
165 - 175 g (5.82 - 6.17 oz)
5. Install slide joint housing, then install new snap ring.
6. Make sure that boot is properly installed on the drive shaft groove.  
Set boot so that it does not swell and deform when its length is "L<sub>2</sub>".  
**Length "L<sub>2</sub>": 97 - 99 mm (3.82 - 3.90 in)**
7. Lock new larger and smaller boot bands securely with a suitable tool.

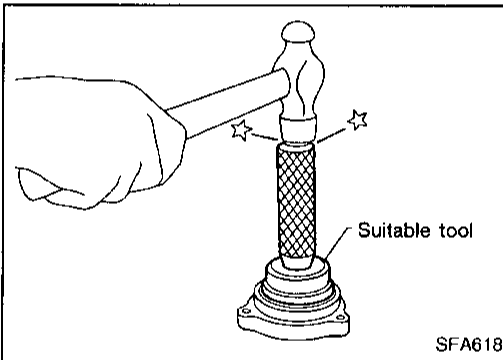

### Support bearing

- Press bearing into retainer.

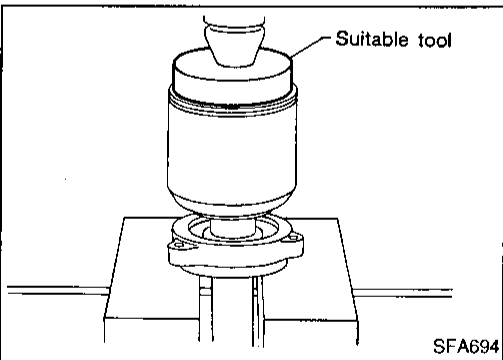

- Press drive shaft into bearing.

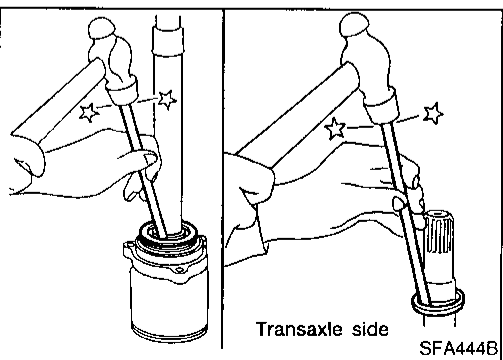

- Install snap ring.
- Install new dust shield.

# FRONT SUSPENSION

## Components

### SEC. 391-400-401

When installing rubber parts, final tightening must be carried out under unladen condition\* with tires on ground.

\* Fuel, radiator coolant and engine oil full.  
Spare tire, jack, hand tools and mats in designated positions.

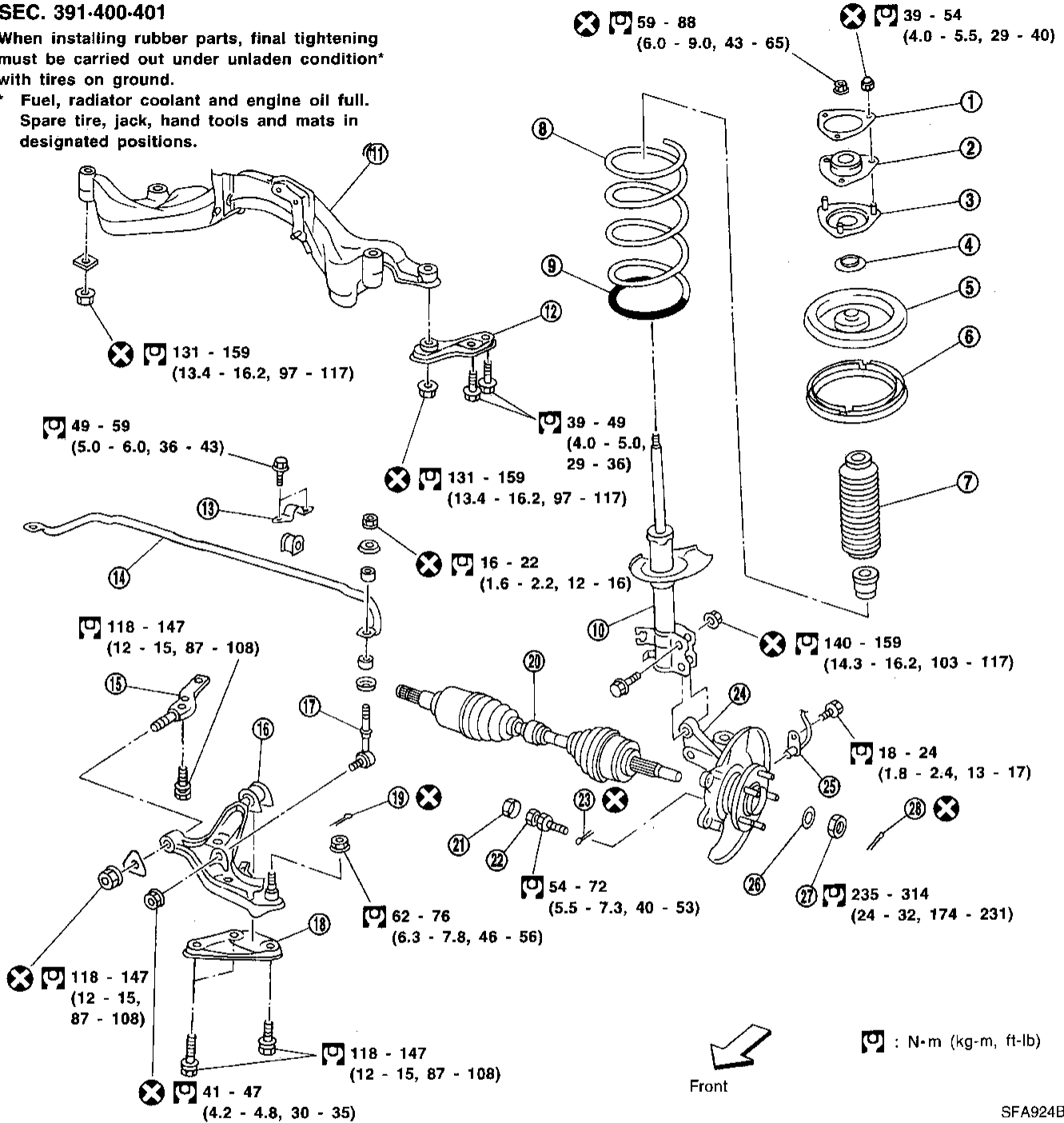

- ① Spacer
- ② Strut mounting insulator
- ③ Strut mounting insulator bracket
- ④ Strut mounting bearing
- ⑤ Upper spring seat
- ⑥ Upper spring rubber seat
- ⑦ Bound bumper
- ⑧ Coil spring
- ⑨ (Polyurethane tube)
- ⑩ Strut assembly

- ⑪ Suspension member
- ⑫ Rebound stopper
- ⑬ Stabilizer clamp
- ⑭ Stabilizer bar
- ⑮ Link bushing pin
- ⑯ Transverse link
- ⑰ Connecting rod
- ⑱ Compression rod bushing clamp
- ⑲ Cotter pin

- ⑳ Drive shaft
- ㉑ Cap
- ㉒ Stopper bolt
- ㉓ Cotter pin
- ㉔ Knuckle
- ㉕ ABS sensor
- ㉖ Plain washer
- ㉗ Wheel bearing lock nut
- ㉘ Cotter pin

GI  
MA  
EM  
LC  
EC  
FE  
CL  
MT  
AT  
FA  
RA  
BR  
ST  
RS  
BT  
HA  
EL  
IDX

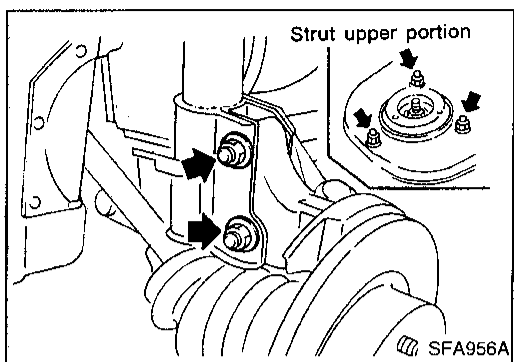

## Coil Spring and Strut Assembly

### REMOVAL AND INSTALLATION

- Remove strut assembly fixing bolts and nuts (to hood-ledge).  
**Do not remove piston rod lock nut on vehicle.**

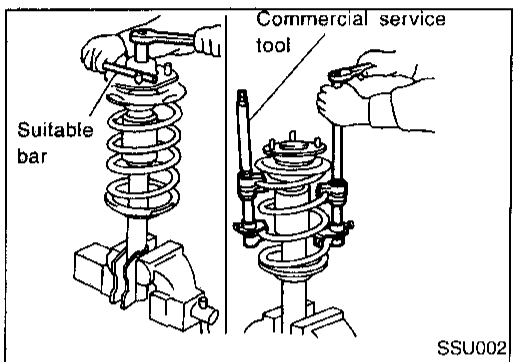

### DISASSEMBLY

1. Set strut assembly on vise, then **loosen** piston rod lock nut.

#### WARNING:

**Do not remove piston rod lock nut.**

2. Compress spring with tool so that the strut mounting insulator can be turned by hand.

#### WARNING:

**Make sure that the pawls of the two spring compressors are firmly hooked on the spring. The spring compressors must be tightened alternately so as not to tilt the spring.**

3. Remove piston rod lock nut.

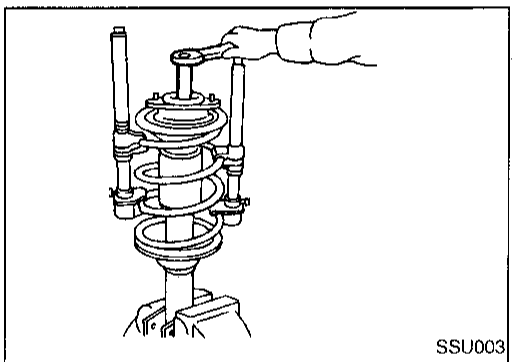

### INSPECTION

#### Shock absorber assembly

- Check for smooth operation through a full stroke, both compression and extension.
- Check for oil leakage on welded or gland packing portion.
- Check piston rod for cracks, deformation or other damage.  
Replace if necessary.

#### Mounting insulator and rubber parts

- Check cemented rubber-to-metal portion for separation or cracks. Check rubber parts for deterioration.  
Replace if necessary.

#### Thrust bearing

- Check thrust bearing parts for abnormal noise or excessive rattle in axial direction.
- Replace if necessary.

#### Coil spring

- Check for cracks, deformation or other damage. Replace if necessary.

# FRONT SUSPENSION

## Coil Spring and Strut Assembly (Cont'd)

### ASSEMBLY

- When installing coil spring on strut, it must be positioned as shown in the figure at left.

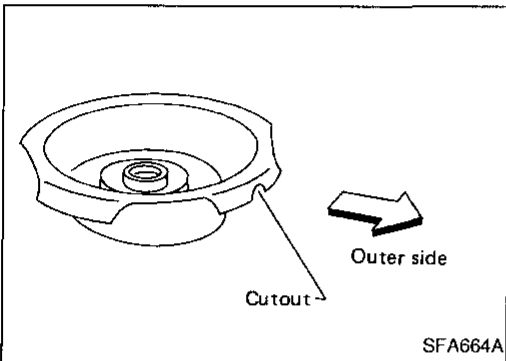
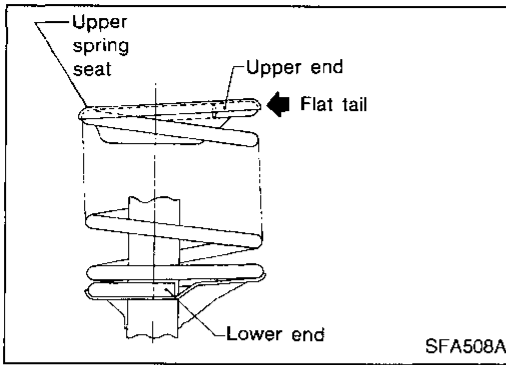

- Install upper spring seat with its cutout facing the outer side of vehicle.

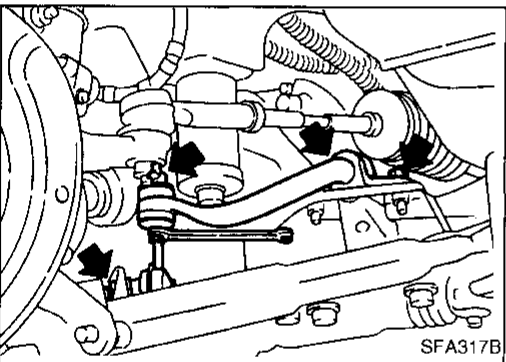

### Stabilizer Bar

#### REMOVAL AND INSTALLATION

- Remove stabilizer bar.

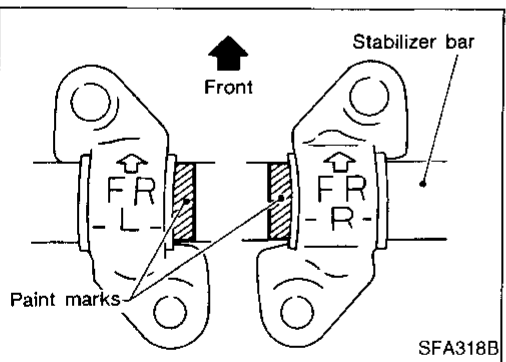

- When installing stabilizer, make sure that paint mark and clamp face in their correct directions.

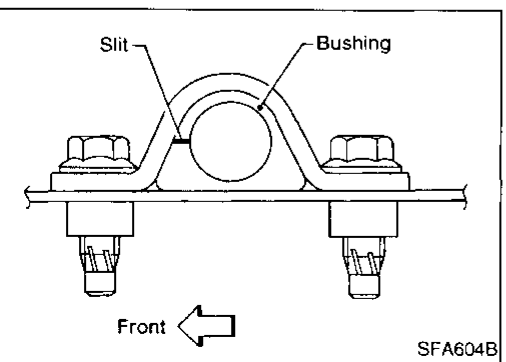

- Make sure that slit in bushing is in the position shown in the figure.

GI

MA

EM

LC

EC

FE

CL

MT

AT

FA

RA

BR

ST

RS

BT

HA

EL

IDX

## FRONT SUSPENSION

### Stabilizer Bar (Cont'd)

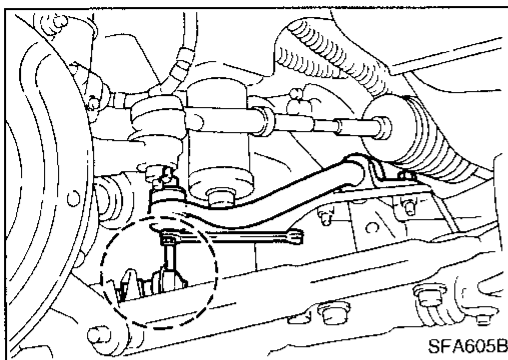

- When removing and installing stabilizer bar.

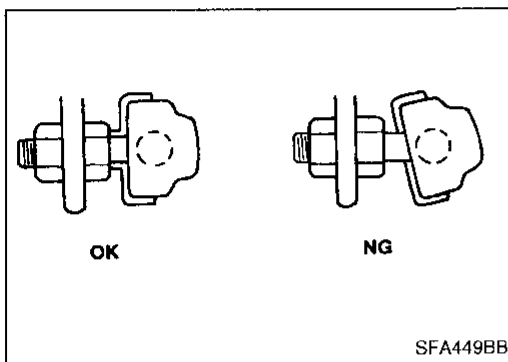

- Install stabilizer bar with ball joint socket properly placed.

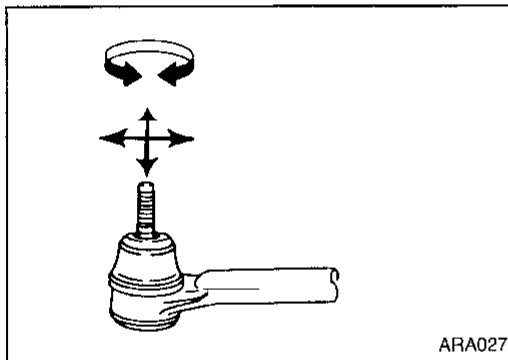

### INSPECTION

- Check stabilizer for deformation or cracks. Replace if necessary.
- Check rubber bushings for deterioration or cracks. Replace if necessary.
- Check ball joint can rotate in all directions. If movement is not smooth and free, replace stabilizer bar connecting rod.

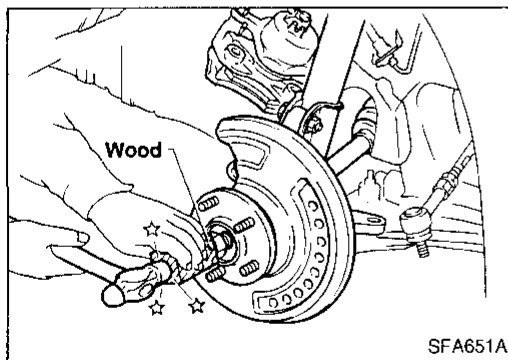

### Transverse Link and Lower Ball Joint

#### REMOVAL AND INSTALLATION

1. Remove wheel bearing lock nut.
2. Remove tie-rod ball joint.
3. Remove strut lower bracket fixing bolts and nuts.
4. Separate drive shaft from knuckle by slightly tapping drive shaft end.

**Cover boots with shop towel so as not to damage them when removing drive shaft.**

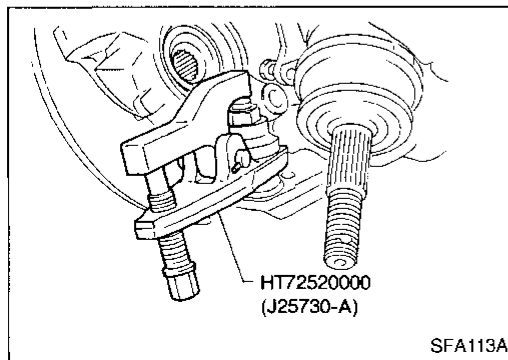

5. Separate lower ball joint stud from knuckle with suitable tool. Refer to FRONT AXLE — Wheel Hub and Knuckle (FA-9).



# FRONT SUSPENSION

## Transverse Link and Lower Ball Joint (Cont'd)

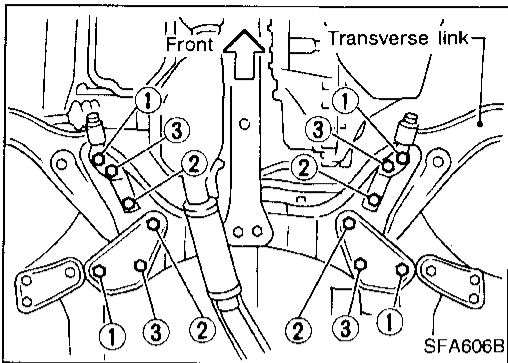

6. Remove fixing bolts.
7. Remove transverse link and lower ball joint.
8. Install fixing bolts in order of number.  
**Tightening torque:**  
Refer to **FRONT SUSPENSION (FA-21)**.
9. During installation, final tightening must be carried out at curb weight with tires on the ground.
10. After installation, check wheel alignment. Refer to **ON-VEHICLE SERVICE — Front Wheel Alignment (FA-7)**.

### INSPECTION

- Check transverse link for damage, cracks or deformation. Replace it if necessary.
- Check rubber bushing for damage, cracks and deformation. Replace transverse link if necessary.

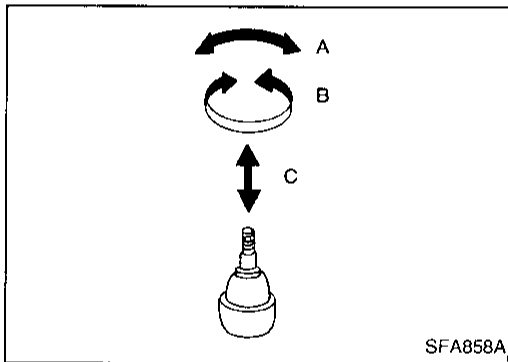

- Check ball joint for play. Replace transverse link assembly if any of the following cases occur. Ball stud is worn, play in axial direction is excessive or joint is hard to swing. Before checking, turn ball joint at least 10 revolutions so that ball joint is properly broken in.

#### Swinging force "A":

(measuring point: cotter pin hole of ball stud):

7.8 - 54.9 N (0.8 - 5.6 kg, 1.8 - 12.3 lb)

#### Turning torque "B":

0.49 - 3.43 N·m (5.0 - 35 kg-cm, 4.3 - 30.4 in-lb)

#### Vertical end play "C":

0 mm (0 in)

- Check dust cover for damage. Replace it and cover clamp if necessary.

GI

MA

EM

LC

EC

FE

CL

MT

AT

FA

RA

BR

ST

RS

BT

HA

EL

IDX

# SERVICE DATA AND SPECIFICATIONS (SDS)

## General Specifications

Suspension type	Independent macpherson struts
Strut type	Double-acting hydraulic
Stabilizer	Standard equipment

## Inspection and Adjustment

### WHEEL ALIGNMENT (Unladen\*1)

Camber	Degree minute (Decimal degree)	Minimum	-1°00' (-1.00°)	
		Nominal	-0°15' (-0.25°)	
		Maximum	0°30' (0.50°)	
		Left and right difference	45' (0.75°) or less	
Caster	Degree minute (Decimal degree)	Minimum	2°00' (2.00°)	
		Nominal	2°45' (2.75°)	
		Maximum	3°30' (3.50°)	
		Left and right difference	45' (0.75°) or less	
Kingpin inclination	Degree minute (Decimal degree)	Minimum	13°30' (13.50°)	
		Nominal	14°15' (14.25°)	
		Maximum	15°00' (15.00°)	
Total toe-in	Distance (A - B)  mm (in)	Minimum	1 (0.04)	
		Nominal	2 (0.08)	
		Maximum	3 (0.12)	
	Angle (left plus right)	Degree minute (Decimal degree)	Minimum	5°30' (0.09°)
			Nominal	11' (0.18°)
			Maximum	16' (0.27°)
Wheel turning angle	Inside	Degree minute (Decimal degree)	Minimum	36°00' (36.00°)
			Nominal	39°30' (39.50°)
	Full turn*2	Degree minute (Decimal degree)	Maximum	40°30' (40.50°)
			Outside	Nominal

\*1: Fuel, radiator coolant and engine oil full. Spare tire, jack, hand tools and mats in designated positions.

\*2: On power steering models, wheel turning force (at circumference of steering wheel) of 98 to 147 N (10 to 15 kg, 22 to 33 lb) with engine idle.

# SERVICE DATA AND SPECIFICATIONS (SDS)

## Inspection and Adjustment (Cont'd)

### WHEELARCH HEIGHT (Unladen\*)

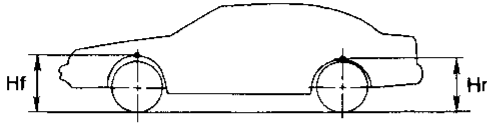

SFA818A

Applied model	*1	*2
Front (Hf) mm (in)	713 (28.07)	713 (28.07)
Rear (Hr) mm (in)	715 (28.15)	713 (28.07)

\*: Fuel, radiator coolant and engine oil full. Spare tire, jack, hand tools and mats in designated positions.

\*1: Models equipped with 205/65 R15 tires

\*2: Models equipped with 215/60 R15 tires

### WHEEL BEARING

Wheel bearing axial end play limit mm (in)	0.05 (0.0020)
Wheel bearing lock nut tightening torque N·m (kg·m, ft·lb)	235 - 314 (24 - 32, 174 - 231)

### LOWER BALL JOINT

Swinging force "A" (Measured at cotter pin hole) N (kg, lb)	7.8 - 54.9 (0.8 - 5.6, 1.8 - 12.3)
Turning torque "B" N·m (kg·cm, in·lb)	0.49 - 3.43 (5.0 - 35, 4.3 - 30.4)
Vertical end play limit "C" mm (in)	0 (0)

### WHEEL RUNOUT

Unit: mm (in)

Wheel type	Aluminum wheel	Steel wheel
Maximum radial runout limit	0.3 (0.012)	0.5 (0.020)
Maximum lateral runout limit	0.3 (0.012)	0.8 (0.031)

### DRIVE SHAFT

Applied model	All
Joint type	
Transaxle side	DS90
Wheel side	ZF100
Boot length mm (in)	
Transaxle side L <sub>2</sub>	97 - 99 (3.82 - 3.90)
Wheel side L <sub>1</sub>	96 - 98 (3.78 - 3.86)
Grease	Nissan genuine grease or equivalent
Capacity g (oz)	
Transaxle side	165 - 175 (5.82 - 6.17)
Wheel side	135 - 145 (4.76 - 5.11)

Boot length  
Wheel side

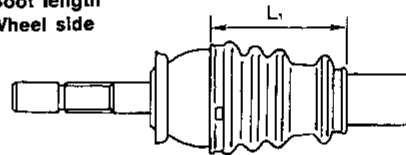

Transaxle side

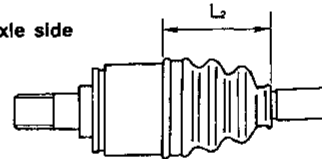

SFA396B