

Safety and Operator Convenience Features

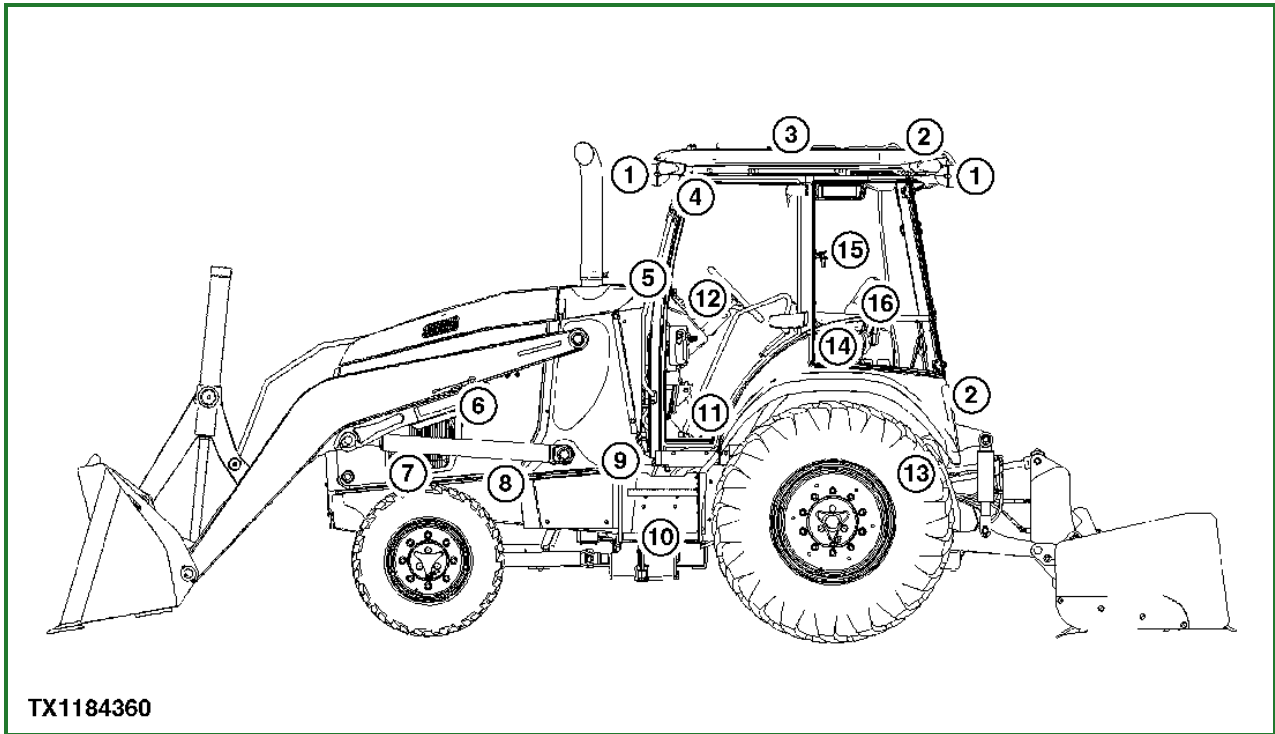

TX1184360

TX1184360-UN: Safety and Operator Conveniences

Please remember, the **operator** is the key to preventing accidents.

1. **Headlights/Taillights**— Two front drive/work lights and two rear work lights.
2. **Signal/Warning Lights**— Roof-mounted turning signal lights and warning lights for on-road use.
3. **Roll-Over Protection Structure (ROPS)**— Certified ROPS surrounds the operator. Integral roof provides overhead protection.
4. **Interior Rearview Mirror**— Mirror offers the operator a view of activity behind them.
5. **Handholds**— Large, conveniently placed handholds help operator to enter or exit the operator's station.
6. **Loader Boom Service Lock**— Loader boom service lock is provided for working on or around this machine with the boom raised.
7. **Engine Fan Guard**— A secondary engine fan guard inside engine compartment encloses rotating fan blades.
8. **Bypass Start Protection**— Shielding over the starter solenoid helps prevent dangerous bypass starting.
9. **Ground-Level Fueling**— Ground-level fueling feature eliminates the need to climb on the machine when fueling.
10. **Steps**— Wide, skid-resistant steps provide excellent footing for getting in/out of operator's station.
11. **Independent Parking/Secondary Brake**— Independent, electrically controlled parking brake electrically engages when the engine is stopped.
12. **Neutral Start**— The machine will not move until the transmission control lever (TCL) is cycled back to neutral and the park brake is released, regardless of TCL position at start-up.
13. **Backup Alarm**— Alarm alerts bystanders when the machine is shifted into reverse.
14. **Seat Belt Retractors**— Seat belt retractors help keep belts clean and convenient to use.
15. **Exceptional Visibility**— Views to either side, front, and rear working tools are unrestricted.
16. **Operator's Manual Holder**— A sealed manual holder keeps manual clean and dry.

Section 1-2: Safety—General Precautions

Information for European Union Directives and Eurasian Economic Union Technical Regulations Compliance

Recognize Safety Information

Follow Safety Instructions

Operate Only If Qualified

Wear Protective Equipment

Protect Against Noise

Avoid Unauthorized Machine Modifications

Inspect Machine

Stay Clear of Moving Parts

Avoid High-Pressure Fluids

Avoid High-Pressure Oils

Work In Ventilated Area

Avoid Static Electricity Risk When Refueling

High Debris Applications

Prevent Fires

In Case of Machine Fire

Prevent Battery Explosions

Handle Chemical Products Safely

Handle Starting Fluid Safely

Decommissioning — Proper Recycling and Disposal of Fluids and Components

Exhaust Filter Ash Handling and Disposal

Prepare for Emergencies

Clean Debris from Machine