

DFT1130 Adapter

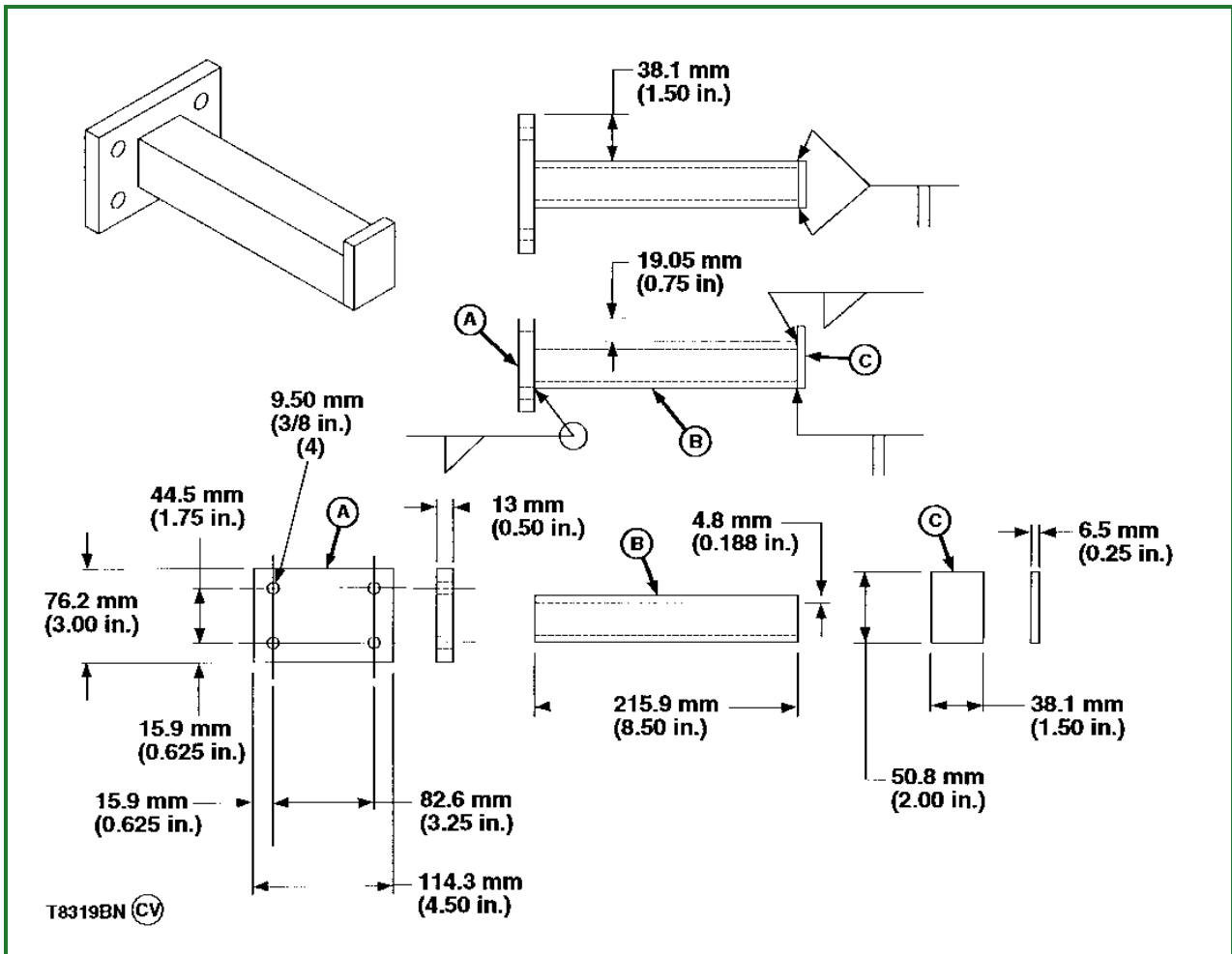

T8319BN-UN: DFT1130 Adapter Specifications

LEGEND:

- A - Steel Plate
- B - Square Tube
- C - Steel Plate

Adapter is used with DF1063 Lift Bracket to remove and install travel motor.

Material required:

- 1.3 mm (1/2 in.) 1020 Steel Plate (A)
- 38.1 mm x 38.1 mm x .48 mm (1-1/2 in. x 1-1/2 in. x 3/16 in.) Square Tube (B)
- .6 mm (1/4 in.) 1020 Steel Plate (C)

Adapter.....DFT1130

Used to remove and install travel motor.

Go to [Section_99:Group_9900](#)

MM16284,0001854-19-20120620

DFT1036A Travel Gear Case Nut Wrench

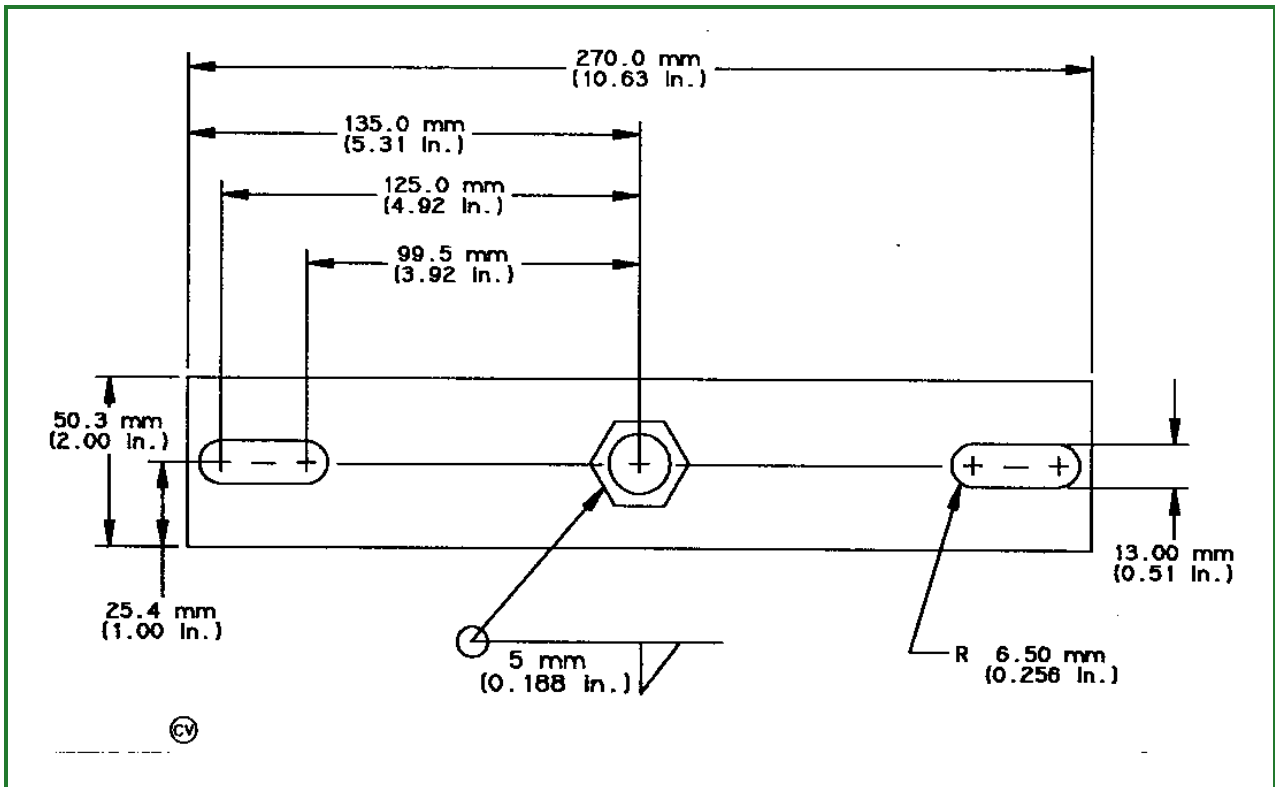

T7681FZ-UN: DFT1036A Dimension Drawing

Travel Gear Case Nut Wrench is used to remove and install the hub-to-housing nut in the travel gear case.

Material required:

- 16 mm (5/8 in.) Flat Bar Stock
- M24 (1 in.) Nut
- M10-1.5 x 60 mm Cap Screw (2 used)
- M10-1.5 Nut (2 used)

Travel Gear Case Nut Wrench.....DFT1036A

Used to remove and install the hub-to-housing nut.

Go to [Section_99:Group_9900](#)

MM16284,0001855-19-20120620