

Clean Transmission Suction Screen (Closed Center)

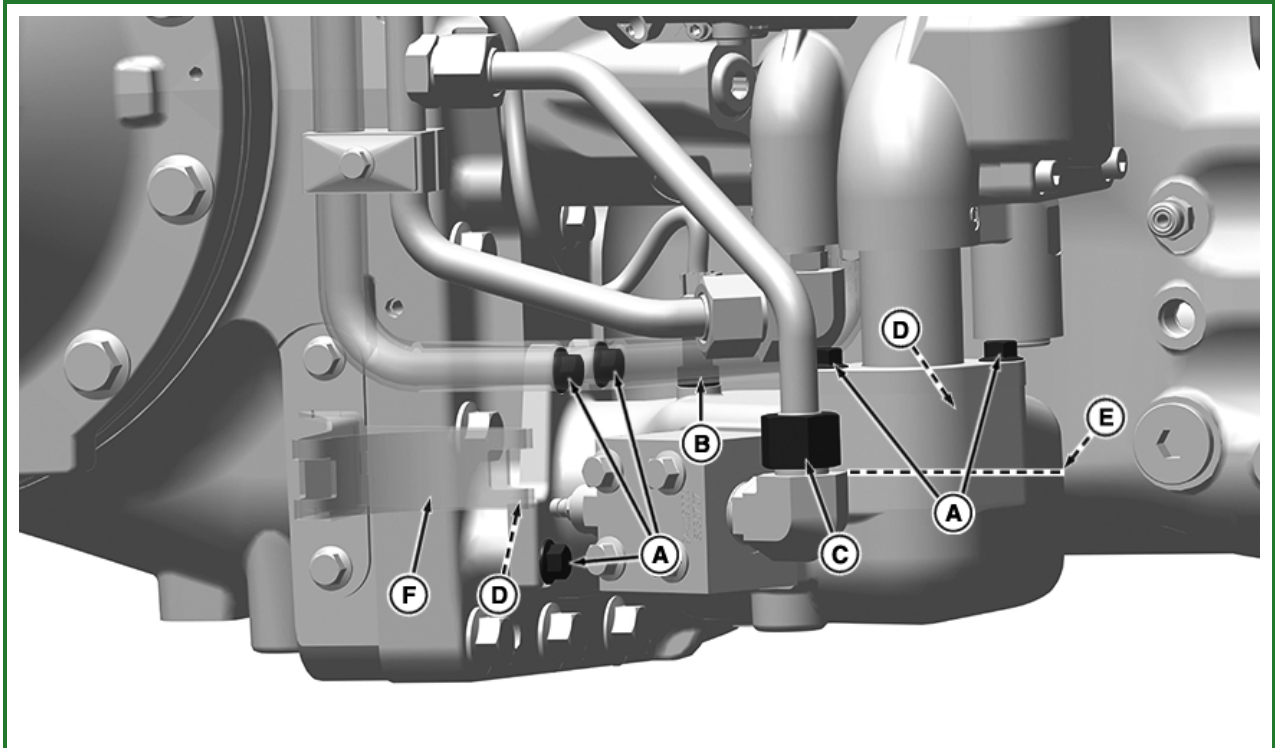

RXA0155650-UN: Behind Right Rear Tire

LEGEND:

A - Suction Screen Housing Cap Screw (6 used)

B - Hydraulic Oil Temperature Sensor

C - Oil Line

D - O-Ring (2 used)

E - Suction Screen

F - Filter Bracket

NOTE:

This procedure must be done after draining the hydraulic oil and removing the filter.

1. Remove filter bracket (F).
2. Remove hydraulic filter.
3. Disconnect connector from sensor (B).
4. Disconnect hydraulic oil line (C).
5. Remove cap screws (A).
6. Remove suction screen housing and suction screen (E).
7. Clean suction screen and replace as required.
8. Install new O-rings (D) in housing.
9. Reinstall in reverse order.

Item	Measurement	Specification
Suction Screen Housing Cap Screws	Torque	70 N·m (50 lb·ft)

GS25068,000560E-19-20180925