

**Circlip and Toothed Washer Installation**

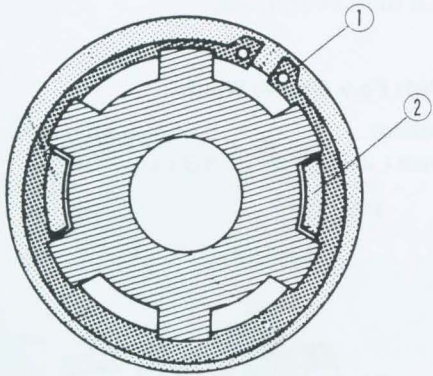

- 1. Circlip
- 2. Toothed Washer

●Using stem bearing driver (special tool: 57001-137), install the ball bearings and collar. The ball bearing for the drive shaft must be pressed on with the set ring groove toward the clutch side. The bearing for the output shaft must be pressed on with the set ring groove toward the opposite side of the engine sprocket.

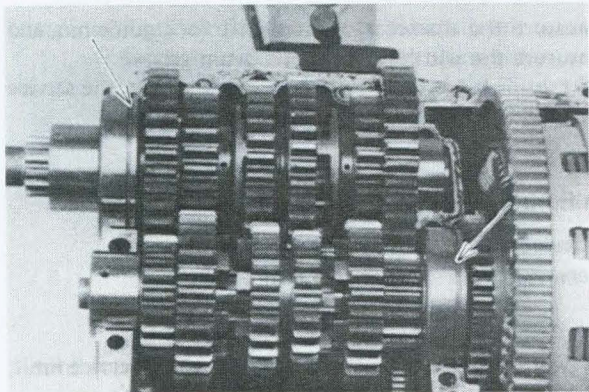

**Shift Drum and Fork Removal**

- Remove the external shift mechanism.
- Remove the oil pump and bracket.
- Unscrew the Allen bolts holding the shift drum ball bearing holder.

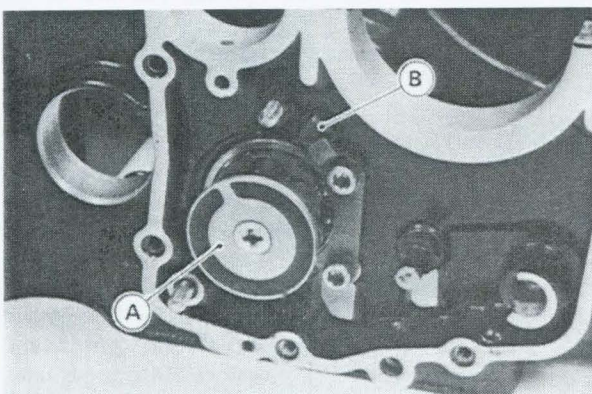

A. Shift Drum      B. Shift Rod

- Pull out the shift rod, and take off the shift forks.
- Pull out the shift drum.

**Shift Drum and Fork Installation**

- Installation is the reverse of removal. Note the following.
- If the shift drum pin plate was removed, install it as following.
- One of the six pins is longer than the others. The long shift drum pin must be installed in the correct position, and must be fit into the correct hole in the back of the pin plate. If these parts are assembled in the wrong position, the neutral indicator light will not light when the gears are in neutral.

**Shift Drum Pin Plate**

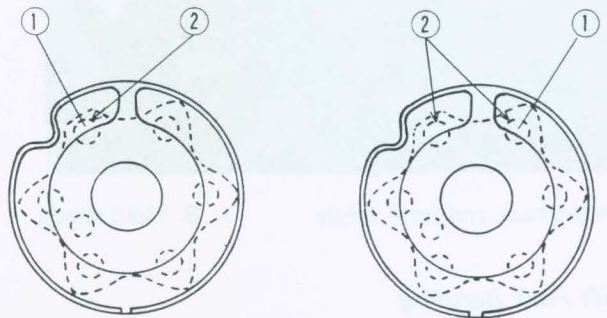

- 1. Long Pin
- 2. Recess in Pin Plate

If the pin plate has two recesses, the long pin should be installed as shown above.

- Apply a non-permanent locking agent to the pin plate screw.
- The shift forks can be identified by their shape. Install them as following.

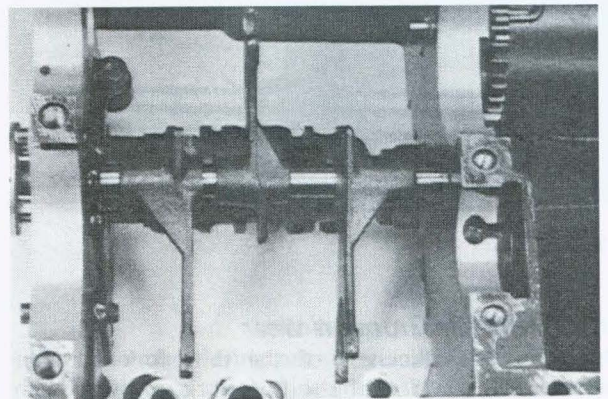

**Transmission Maintenance:**

**Gear Backlash**

- Split the crankcase leaving the transmission in place.
- Set a dial gauge against the teeth on one gear, and move the gear back and forth while holding the other gear steady. The difference between the highest and the lowest gauge readings is the amount of backlash.

## 8-22 CRANKSHAFT/TRANSMISSION

★Replace both gears if the amount of backlash exceeds the service limit.

### Gear Backlash

|                |                |
|----------------|----------------|
| Standard:      | 0.06 – 0.23 mm |
| Service Limit: | 0.3 mm         |

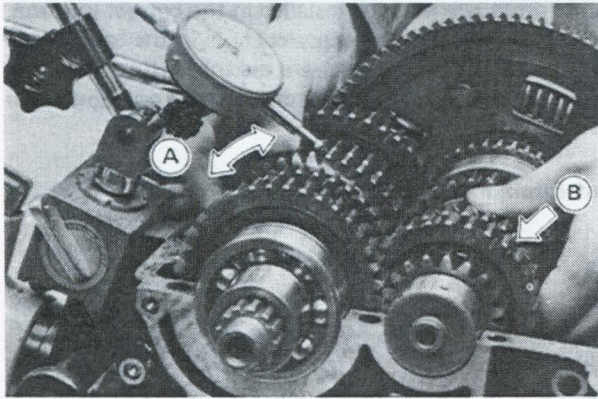

A. Move back and forth lightly.

B. Hold steady.

### Shift Fork Bending

●Visually inspect the shift forks, and replace any fork that is bent. A bent fork could cause difficulty in shifting, or allow the transmission to jump out of gear when under power.

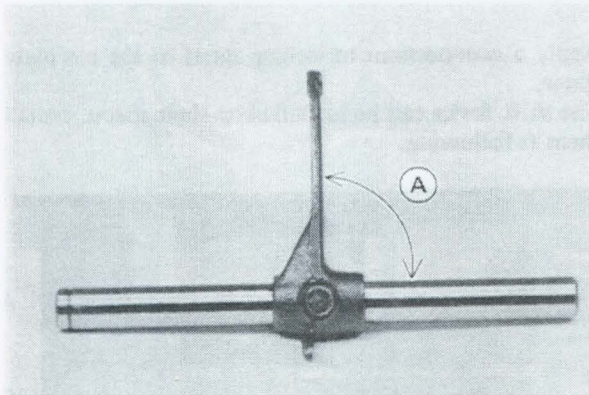

A. 90°

### Shift Fork/Gear Groove Wear

●Measure the thickness of the shift fork ears, and measure the width of the shift fork grooves on the transmission gears.

★If the thickness of a shift fork ear is less than the service limit, the shift fork must be replaced.

### Shift Fork Ear Thickness

|                |              |
|----------------|--------------|
| Standard:      | 4.9 – 5.0 mm |
| Service Limit: | 4.8 mm       |

★If a gear shift fork groove is worn over the service limit, the gear must be replaced.

### Gear Shift Fork Groove Width

|                |                |
|----------------|----------------|
| Standard:      | 5.05 – 5.15 mm |
| Service Limit: | 5.3 mm         |

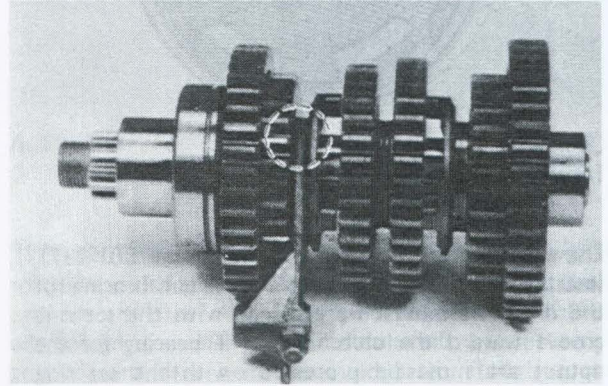

### Shift Fork Guide Pin/Shift Drum Groove Wear

●Measure the diameter of each shift fork guide pin, and measure the width of each shift drum groove.

★If the guide pin on any shift fork is less than the service limit, the fork must be replaced.

### Shift Fork Guide Pin Diameter

|                |              |
|----------------|--------------|
| Standard:      | 7.9 – 8.0 mm |
| Service Limit: | 7.8 mm       |

★If any shift drum groove is worn over the service limit, the drum must be replaced.

### Shift Drum Groove Width

|                |                |
|----------------|----------------|
| Standard:      | 8.05 – 8.20 mm |
| Service Limit: | 8.3 mm         |

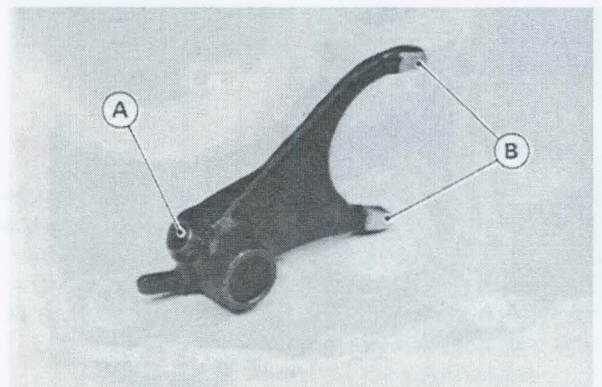

A. Shift Fork Guide Pin

B. Shift Fork Ears

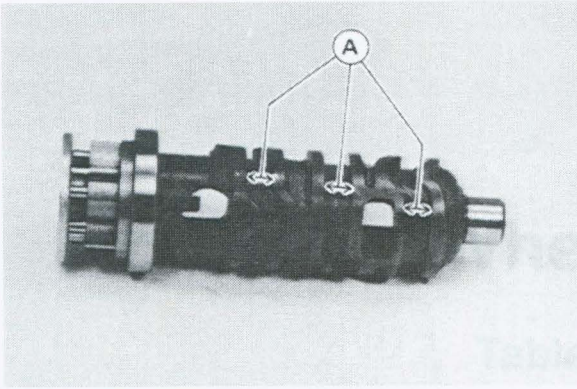

A. Shift Drum Grooves

### *Gear Dog/Gear Dog Hole Damage*

- Visually inspect the gear dogs and gear dog holes.
- ★Replace any gears that have damaged or excessively worn dogs or dog holes.

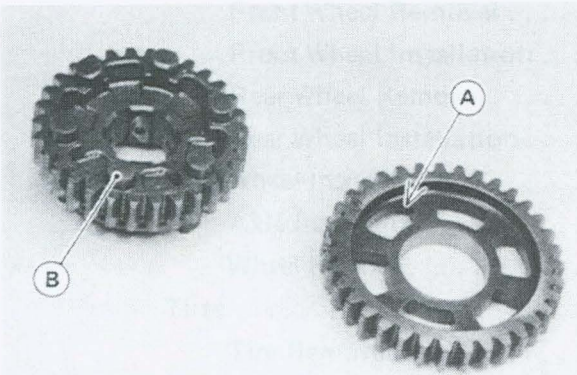

A. Dog Hole

B. Dog

### *Ball and Needle Bearing Wear*

- Check the following ball bearings: shift drum LH, drive shaft RH, and output shaft LH.
- Since the ball bearings are made to extremely close tolerances, the wear must be judged by feel rather than measurement. Clean each bearing in a high flash-point solvent, dry it (do not spin the bearing while it is dry), and oil it with engine oil.
- Spin the bearing by hand to check its condition.
- ★If the bearing is noisy, does not spin smoothly, or has any rough spots, replace it.
- Check the following needle bearing: drive shaft LH and output shaft RH.
- The rollers in a needle bearing normally wear very little, and wear is difficult to measure. Instead of measuring, inspect the bearing for abrasion, color change, or other damage.
- ★If there is any doubt as to the condition of a needle bearing, replace it.

# Wheels/Tires

## Table of Contents

|  |      |
|--|------|
| Exploded View .....                          | 9-2  |
| Specifications .....                         | 9-3  |
| Special Tools .....                          | 9-3  |
| Wheels (Rims) .....                          | 9-4  |
| Front Wheel Removal .....                    | 9-4  |
| Front Wheel Installation .....               | 9-4  |
| Rear Wheel Removal .....                     | 9-4  |
| Rear Wheel Installation .....                | 9-5  |
| Wheel Inspection .....                       | 9-5  |
| Axle Inspection .....                        | 9-6  |
| Wheel Balance .....                          | 9-6  |
| Tires .....                                  | 9-8  |
| Tire Removal .....                           | 9-8  |
| Tire Installation .....                      | 9-9  |
| Tire Inspection .....                        | 9-10 |
| Tire Repair .....                            | 9-11 |
| Hub Bearings .....                           | 9-11 |
| Front Hub Bearing Removal .....              | 9-11 |
| Front Hub Bearing Installation .....         | 9-12 |
| Rear Hub Bearing Removal .....               | 9-12 |
| Rear Hub Bearing Installation .....          | 9-13 |
| Hub Bearing Inspection and Lubrication ..... | 9-13 |
| Grease Seal Inspection and Lubrication ..... | 9-14 |
| Speedometer Gear Housing .....               | 9-14 |
| Speedometer Gear Housing Disassembly .....   | 9-14 |
| Speedometer Gear Housing Assembly .....      | 9-14 |
| Speedometer Gear Housing Lubrication .....   | 9-15 |

## 9-2 WHEELS/TIRES

### Exploded View

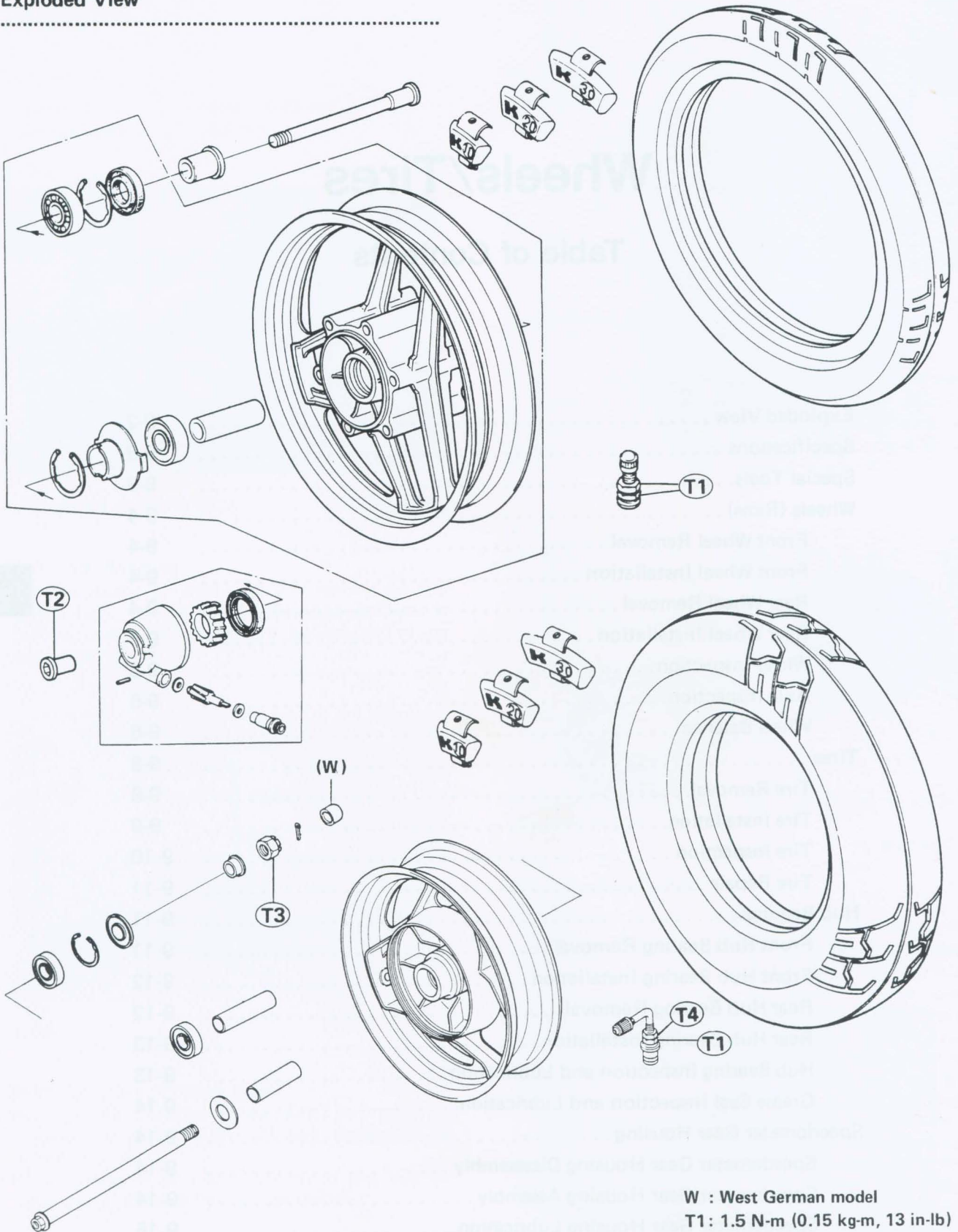

W : West German model

T1: 1.5 N-m (0.15 kg-m, 13 in-lb)

T2: 88 N-m (9.0 kg-m, 65 ft-lb)

T3: 110 N-m (11.0 kg-m, 80 ft-lb)

T4: 5.9 N-m (0.60 kg-m, 52 in-lb)