

**Clutch Cover Oil Pump Removal**

- Remove the clutch cover [A] (see Clutch chapter).
- Remove the oil pump bolts [B].

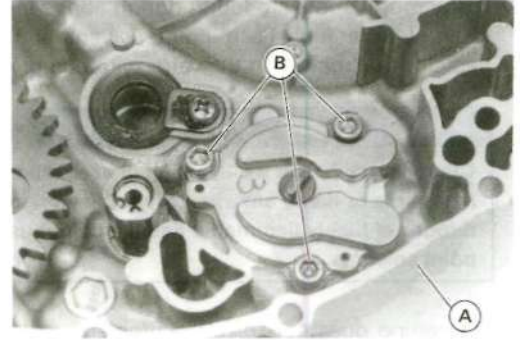
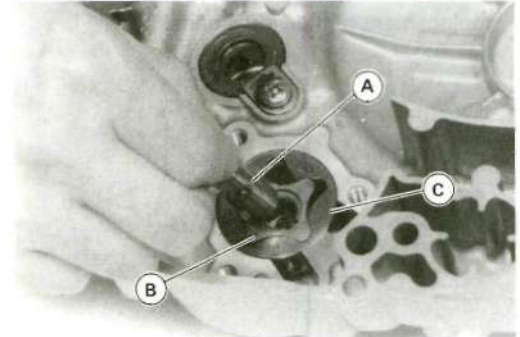

- Remove:
  - Oil Pump Shaft [A]
  - Inner Rotor [B]
  - Outer Rotor [C]

**Clutch Cover Oil Pump Installation**

- Install the dowel pins [A].
- Fill the pump with engine oil [B] for initial lubrication.

**Torque - Oil Pump Bolts : 12 N-m (1.2 kg-m, 104 in-lb)**

- Install the clutch cover (see Clutch chapter).

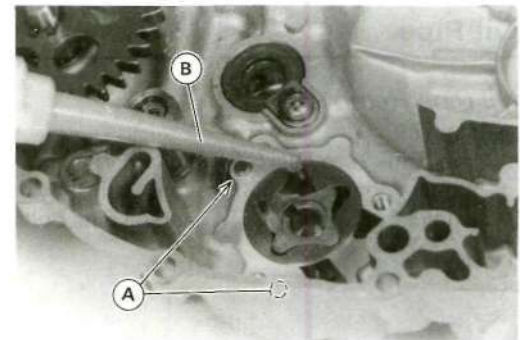
**Oil Pump Inspection**

- Disassemble the oil pump (see this chapter).
  - Visually inspect the oil pump body, outer and inner rotors, and covers.
- \*If there is any damage or uneven wear, replace the rotors or the oil pump assembly.

**Relief Valve Inspection**

- Remove the clutch cover [A] (see Clutch chapter).
- Remove the relief valve [B].
- Check to see if the steel ball [C] inside the valve slides smoothly when pushing it in with a wooden or other soft rod, and see if it comes back to its seat by valve spring pressure.

**NOTE**

*Inspect the valve in its assembled state. Disassembly and assembly may change the valve performance.*

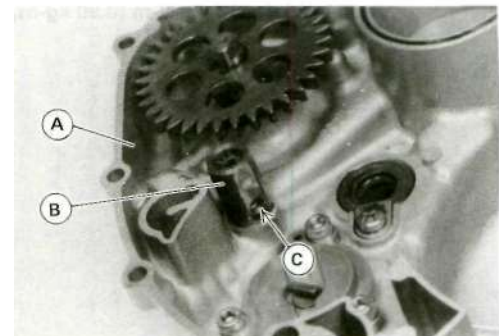

## 6-12 ENGINE LUBRICATION SYSTEM

\* If any rough spots are found during above inspection, wash the valve clean with a high-flash point solvent and blow out any foreign particles that may be in the valve with compressed air.

### **AWARNING**

**Clean the parts in a well-ventilated area, and take care that there are no sparks or flame anywhere near the working area. Because of the danger of highly flammable liquids, do not use gasoline or low-flash point solvents.**

\* If cleaning does not solve the problem, replace the relief valve as an assembly. The relief valve is precision made with no allowance for replacement of individual parts.

## Oil Pipe

### *Oil Pipe Removal*

- Remove:
  - Fuel Tank (see Fuel System chapter)
  - Starter Motor (KLX650C, see Electrical System chapter)
- Remove the banjo bolts [A] and oil pipe bolts [B] to take off the pipe.

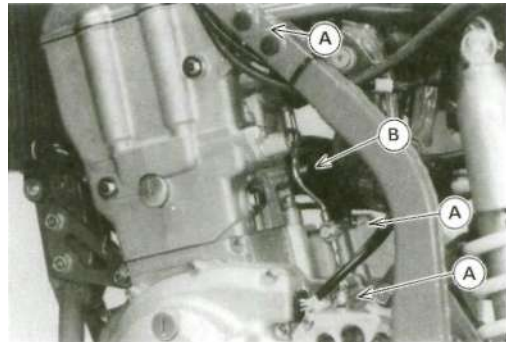

### *Oil Pipe Installation*

- Before installation, flush out the pipe with a high-flash point solvent.
- Fill the pipe with engine oil to shorten air bleeding time and prevent engine damage.
- Discard the used copper washers and install new washers on each side of the pipe fittings.
- Lightly tighten the banjo bolts and oil pipe bolts to a snug fit, and tighten them to the specified torque.

**Torque - Oil Pipe Banjo Bolts : 20 N-m (2.0 kg-m, 14.5 ft-lb)**  
**Oil Pipe Bolts : 8.8 N-m (0.90 kg-m, 78 in-lb)**

# Engine Removal / Installation

## Table of Contents

Exploded View.....	7-2
Specifications.....	7-3
Engine Removal/Installation.....	7-3
Engine Removal.....	7-3
Engine Installation.....	7-5



## 7-2 ENGINE REMOVAL / INSTALLATION

Exploded View

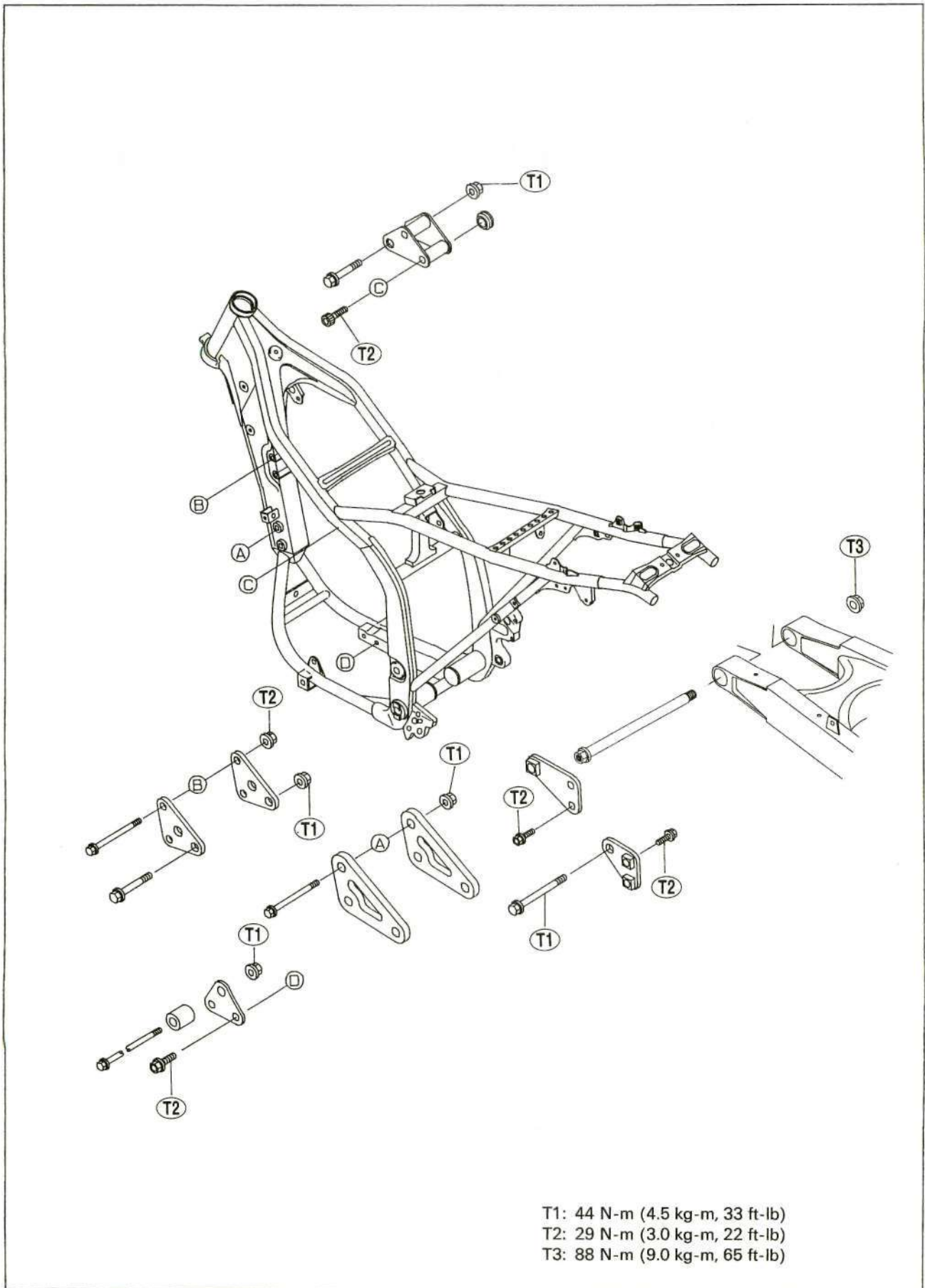

## Specifications

**Special Tool - Jack: 57001-1238**

## Engine Removal/Installation

### *Engine Removal*

- Drain the coolant (see Cooling System chapter)
- Drain the engine oil (see Engine Lubrication System chapter).
- Remove:
  - Fuel Tank (see Fuel System chapter)
  - Carburetor (see Fuel System chapter)
  - Exhaust Pipe (see Engine Top End chapter)
  - Right Footpeg
  - Brake Pedal (see Brakes chapter)
  - Shift Pedal
  - Radiators (see Cooling System chapter)
  - Engine Sprocket [A] (see Final Drive chapter)
  - Kick Pedal (KLX600A)
  - Canister Guard (KLX650C, CA)

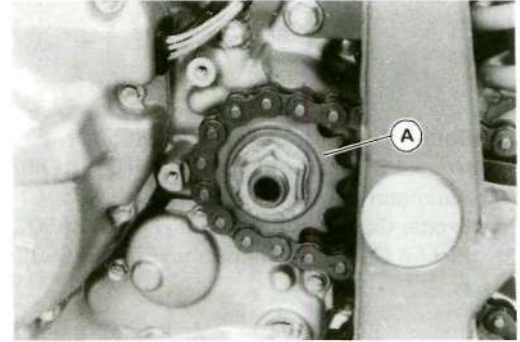

- Disconnect the following cables, hoses, and connectors from the engine.
  - Breather Hose [A]
  - Spark Plug Cap [B]
  - Radiator Hoses
  - Clutch Cable Lower End (see Clutch Cover Removal in the Clutch chapter)

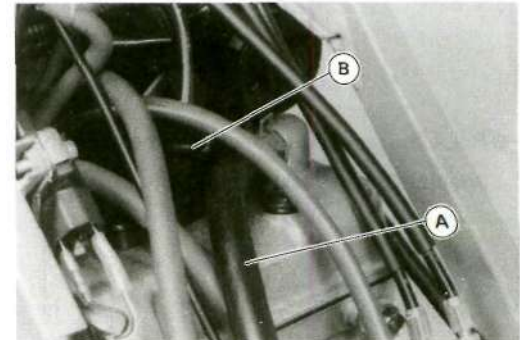

Alternator Lead Connector [A] (KLX650A)

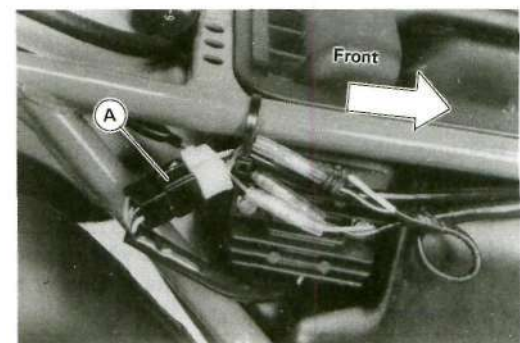



## 7-4 ENGINE REMOVAL / INSTALLATION

Pickup Coil Lead Connector [A] (KLX650A)  
Exciter Coil Lead Connector [B] (KLX650A)

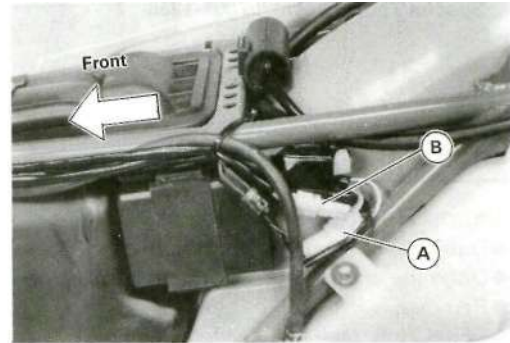

Battery Negative Lead [A] (KLX650C)  
Neutral Switch Lead Connector [B] (KLX650C)  
Alternator Lead Connector [C] (KLX650C)  
Exciter Coil Lead Connector [D] (KLX650C)  
Pickup Coil Lead Connector [E] (KLX650C)

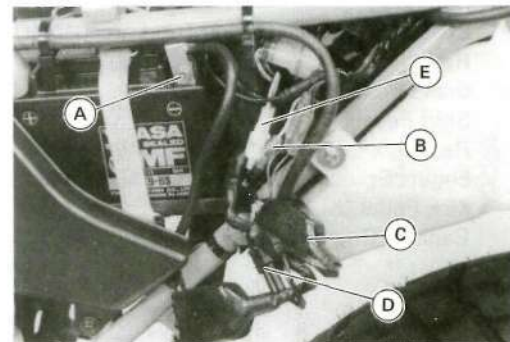

Starter Motor Cable [A] (KLX650C)

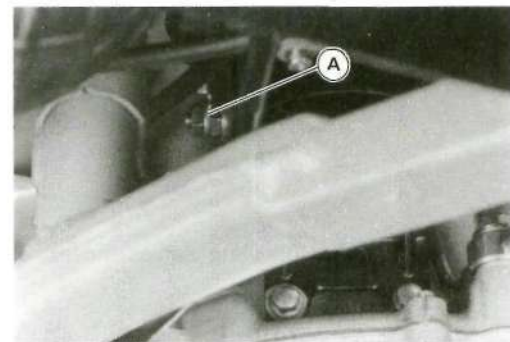

»Place the jack [A] under the frame to lift the rear wheel off the ground.

**Special Tool - Jack: 57001-1238**

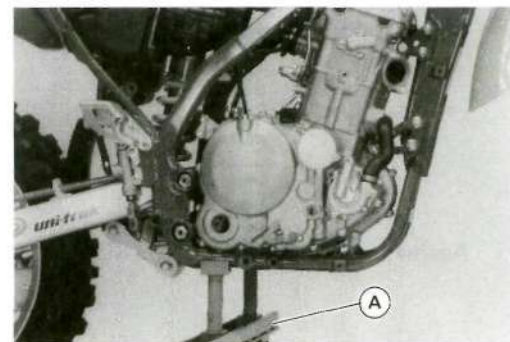

•Squeeze the brake lever slowly and hold it with a band [A].

### CAUTION

**Be sure to hold the front brake when removing the engine, or the motorcycle may fall over. The engine or the motorcycle could be damaged.**

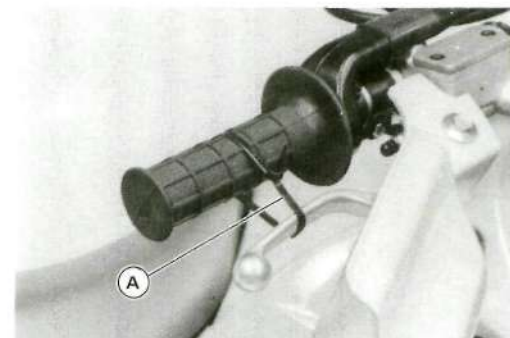

**A WARNING**

Be sure to hold the front brake when removing the engine, or the motorcycle may fall over. It could cause an accident and injury.

The following parts may be removed with the engine in the frame if the crankcase is to be split.

- Primary Gear (see Clutch chapter)
- Clutch (see Clutch chapter)
- Magneto Flywheel (see Electrical System chapter)

- Remove the engine mounting bolts [A] and brackets [B].

**A WARNING**

The swingarm pivot shaft also serves as the engine mounting bolt. Take precautions to insure the frame is well supported, so that the motorcycle will not fall over when the pivot shaft is removed.

- Remove the swingarm pivot nut.
- Pull out the swingarm pivot shaft [C] halfway so that the engine is free and the swingarm doesn't fall down.

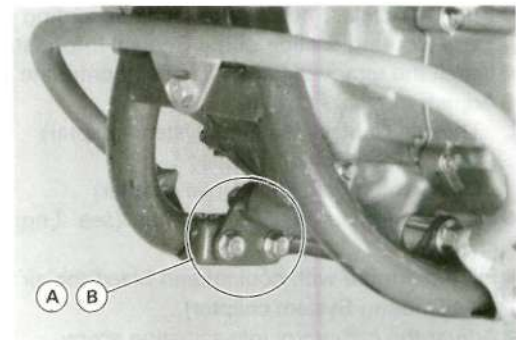
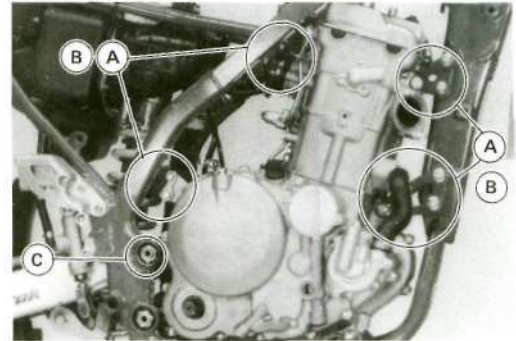

- Twist the engine clockwise and remove the engine [A] from the vehicle's right side.

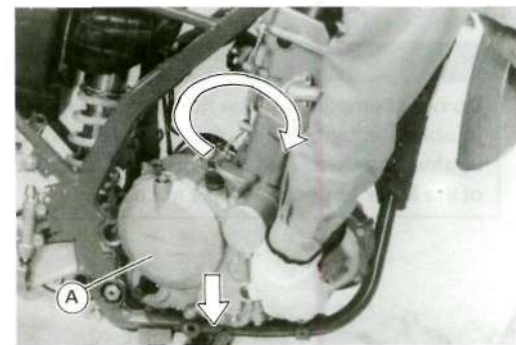
**Engine Installation**

- For the KLX650C model, hang the drive chain [A] over the output shaft [B] just before moving the engine into its final position in the frame.
- Insert the swingarm shaft.

**NOTE**

If the swingarm is removed and is difficult to install, remove the brake pedal and loosen the rocker arm nut.

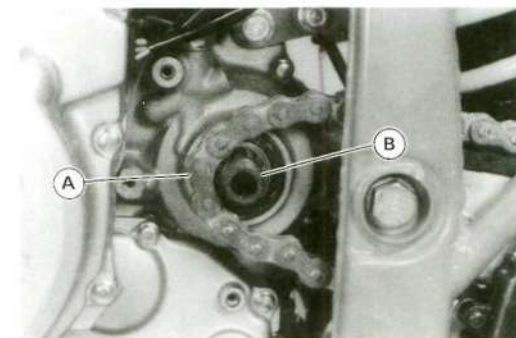

## 7-6 ENGINE REMOVAL / INSTALLATION

- Temporarily install:
  - Front Lower Engine Mounting Bolts [A]
  - Front Lower Engine Mounting Bolt and Nut [B]
  - Other Engine Mounting Bolts and Nuts
- Tighten the following fasteners in the order listed.
  - Torque - Swingarm Pivot Nut: 88 N-m (9.0 kg-m, 65 ft-lb)**
  - Rocker Arm Nut: 98 N-m (10.0 kg-m, 72 ft-lb)**
  - 10 mm Engine Mounting Bolts and Nuts:**
    - 44 N-m (4.5 kg-m, 33 ft-lb)**
  - 8 mm Engine Mounting Bolts and Nuts:**
    - 29 N-m (3.0 kg-m, 22 ft-lb)**

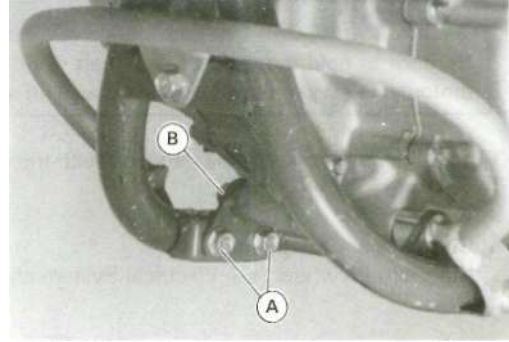

- Install:
  - Engine Sprocket (see Final Drive chapter)
  
- Run the cables, hoses, and leads according to the Cable, Wire, and Hose Routing section of the General Information chapter.
- Install the removed parts (see the appropriate chapters).
- Adjust:
  - Throttle Cables (see Fuel System chapter)
  - Clutch (see Clutch chapter)
  - Drive Chain (see Final Drive chapter)
- Fill the engine with engine oil (see Engine Lubrication System chapter).
- Fill the engine with coolant and bleed the air from the cooling system (see Cooling System chapter).
- Adjust the carburetor idle adjusting screw.
- Check the brake effectiveness.

### **AWARNING**

**Do not attempt to ride the motorcycle until a full brake lever or pedal is obtained by pumping the brake lever or pedal until the pads are against the disc. The brake will not function on the first application of the lever or pedal if this is not done.**



# Crankshaft / Transmission

## Table of Contents

Exploded View.....	8-2
Specifications.....	8-4
Crankcase.....	8-5
Crankcase Disassembly.....	8-5
Crankcase Assembly.....	8-6
Crankshaft and Connecting Rod.....	8-9
Crankshaft Removal.....	8-9
Crankshaft Installation.....	8-9
Crankshaft Disassembly.....	8-9
Crankshaft Assembly.....	8-9
Connecting Rod Big End Seizure.....	8-10
Connecting Rod Big End Radial Clearance.....	8-10
Connecting Rod Big End Side Clearance.....	8-10
Crankshaft Alignment.....	8-10
Transmission.....	8-12
Shift Pedal Installation.....	8-12
External Shift Mechanism Removal.....	8-12
External Shift Mechanism Installation.....	8-13
External Shift Mechanism Inspection.....	8-14
Transmission Removal.....	8-14
Transmission Installation.....	8-14
Transmission Shaft Disassembly.....	8-15
Transmission Shaft Assembly.....	8-15
Shift Fork Bending.....	8-16
Shift Fork Ear/Gear Shift Fork Groove Wear.....	8-16
Shift Fork Guide Pin/Shift Drum Groove Wear.....	<b>8-17</b>
Gear Dog/Dog Recess Damage.....	8-17
Balancer.....	8-18
Balancer Shaft Removal.....	8-18
Balancer Shaft Installation.....	8-18
Balancer Shaft Disassembly.....	8-18
Balancer Shaft Assembly.....	8-18
Ball Bearing, Needle Bearing, and Oil Seal.....	8-20
Ball and Needle Bearing Replacement.....	8-20
Ball and Needle Bearing Wear.....	8-20
Oil Seal Inspection.....	8-20

## 8-2 CRANKSHAFT/TRANSMISSION

### Exploded View

