

CONTROL LEVER AND PEDAL

OPERATING FORCE OF CONTROL LEVER

Special tools

Part No.	Part Name
On the market	<ul style="list-style-type: none"> • Push-pull scale • Spring scale

Install push-pull scale at center of control lever, knob, and measure the force by pulling toward operating direction.

Name of lever	Operating force	Conditions
Range lever	Less than 3.0 ± 0.5 kg	Hydraulic oil temp. at 45 to 55°C
Direction lever	Less than 3.0 ± 0.5 kg	Engine at low idle

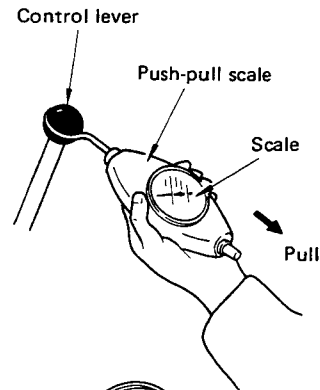

FN8038

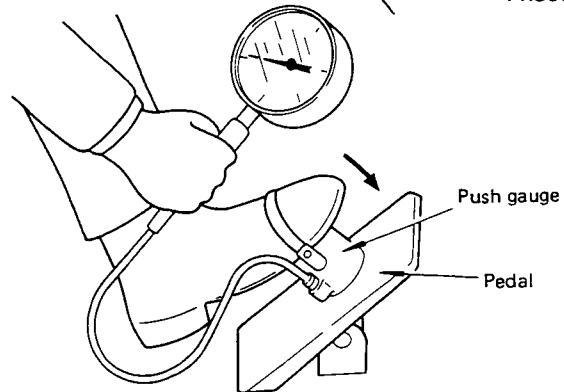

FN8039

DEPRESSING FORCE OF PEDALS

Special tool

Part No.	Part Name
799-101-1001	Push gauge

Put a push gauge on inspector's foot, and measure the depressing force at end of pedal stroke.

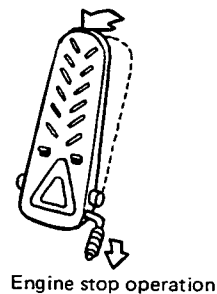

Accelerator pedal	4 to 8 kg	
Brake pedal	45 ± 9 kg	Measure at 150 mm point from pedal fulcrum. Read max. force.
Engine stop operation	Less than 10 kg	Measure at stop lever (Accelerator pedal)

PEDAL STROKE

Check pedal stroke at pedal top end.

Accelerator pedal stroke (L_1)	$10^\circ \pm 1^\circ$
Brake pedal stroke	20 ± 2 mm
Engine stop stroke (L_2)	20 mm
Accelerator pedal stopper height (L_3)	When engine governor lever comes to contact with "full" side stopper, the pedal must be contacted to the stopper.

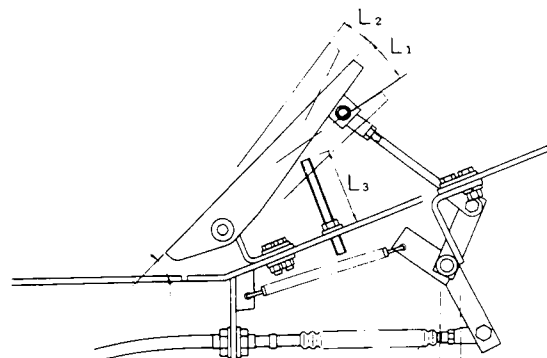

530F085

ENGINE OIL PRESSURE AND COOLANT TEMPERATURE

ENGINE OIL PRESSURE

Special tool

Part number	Part name
790-301-1103	Hydraulic tester

- Remove engine oil pressure switch (5), and install pressure gauge to (1).
 - Screw size: PT1/8
- Start the engine and run the engine at low idling, then at high idling. Read pressure gauge at each idling.

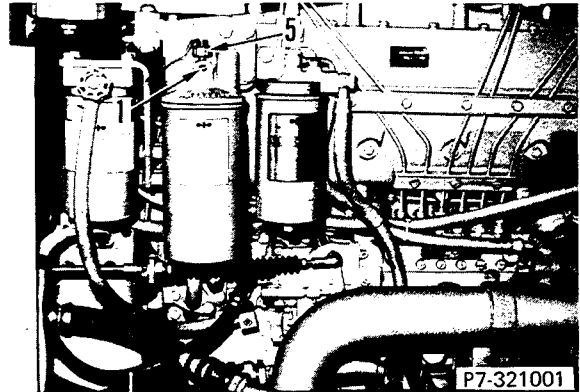

1. Engine oil pressure tap

Engine oil pressure reading at low idling	More than 1.0 kg/cm ²
Engine oil pressure reading at high idling	3.5 ~ 5.5 kg/cm ²

ENGINE COOLANT TEMPERATURE

Special tool

Part number	Part name
790-500-1300	Thermister kit

 To avoid burns, do not carry out these works when hot coolant is in line.

- Drain coolant from radiator.
- Remove pipe (6) and remove thermostat.

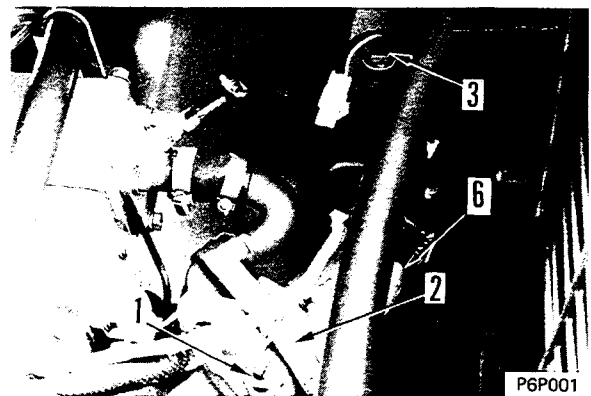

- Thermostat housing
- Engine water temperature switch
- Engine water temperature sensor

CHECK OF THERMOSTAT

- Place the thermostat and thermometer in the water as shown in the figure. Gradually heat water in the container until thermostat opening temperature (approx. 80°C), by mixing water to obtain uniform temperature.
- Maintain the above temperature for more than five minutes, and confirm that the thermostat opens.
- Heat water up to 90°C or 95°C, then wait more than 5 minutes. Confirm that valve stroke is more than 10 mm.
- Then, cool down water temperature lower than 70°C and confirm that the valve closely seats.

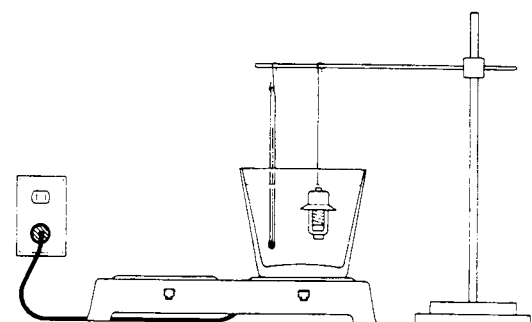

530F086

STALL PERFORMANCE

 Park the machine on level ground, ground the bucket, shut down the engine, then apply the parking brake and place blocks under the tires.

1. Check coolant temperature and oil pressure gauges for correct indications. Check oil leaks.
2. Start the engine and confirm that engine coolant and torque converter oil temperature is in operating range.

★ Test conditions.

- Engine coolant temperature:
at normal operating temperature: 75 to 90°C
- Torque converter oil temperature: 70 to 80°C
- Hydraulic fluid temperature: 45 to 55°C

ENGINE IDLING CHECK

 To check engine speed, two persons are required. Confirming working safety, one person checks engine speed while another operates controls in the operator's compartment. Pay full attention not to touch with fan belt, fan or exhaust tube.

1. Install a reflection mark (1), on crankshaft pulley or dumper. Check engine speed by directing light of the counter to the reflection mark.
2. Reading should be within followings

Low idling rpm	650 to 700 rpm
High idling rpm	2700 to 2800 rpm

★ If idling speeds are not met above ranges, adjust throttle linkage.
Use an accurate tachometer.
If throttle linkage can not adjust the speed, check engine troubles.

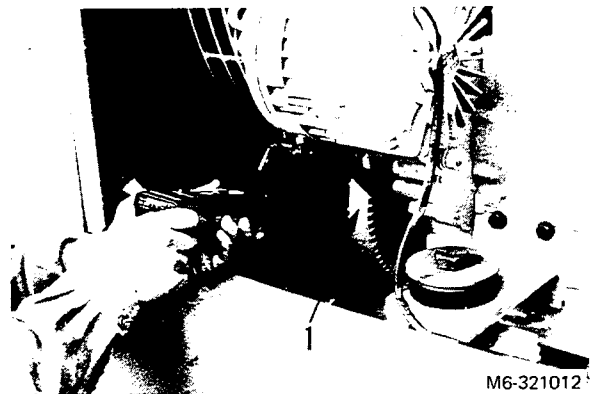

TORQUE CONVERTERS STALL

1. Place transmission control levers in forward and 3rd range.
2. Depress R.H. brake pedal and accelerator pedal fully.
3. Check engine speed with tachometer.

Engine speed at torque converter stall:
2500 to 2700 rpm

- ★ Take care that oil temperature of torque converter never exceed 120°C.
- ★ When torque converter is stalled, confirm that upper drive shaft is stopped.
 If upper drive shaft rotates, clutch plates are slipping.

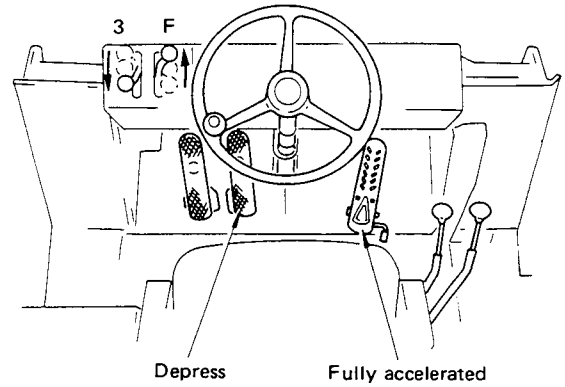

FN8040

HYDRAULIC STALL

1. Fully depress accelerator pedal.
2. Roll back bucket and hold lever. Then check engine speed with tachometer.
 - Avoid stalling for more than a few seconds.
 - Hydraulic stall speed: **2300 to 2600 rpm**

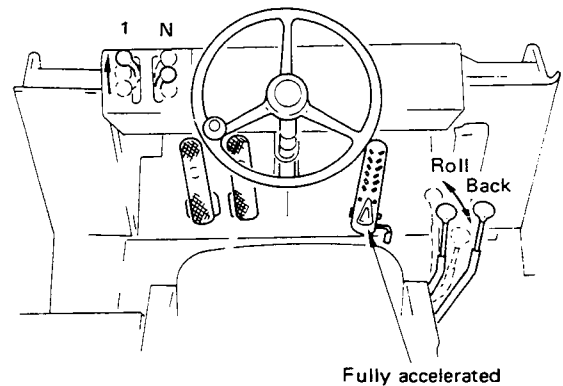

FN8041

FULL STALL

Make torque converter stall and hydraulic stall at the same time to check full stall speed.

- Full stall speed: **1550 to 1950 rpm**
- ★ If reading is out of specifications, inspect the items listed below to find the cause of the trouble.
 - 1) Engine power down
 - 2) Defective torque converter
 - 3) Defective hydraulic circuits for torque converter, transmission.
 - 4) Defective hydraulic circuit for main hydraulic system.

MEASURING OIL PRESSURE

OIL PRESSURE IN TORQUE CONVERTER AND TRANSMISSION

 Park the machine on level ground, ground the bucket, apply the parking brake and place blocks under the tires.

1. Torque converter outlet pressure tap
2. Torque converter relief valve

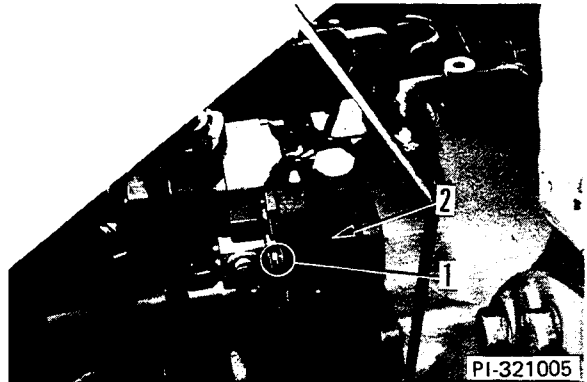

1. Shut down the engine remove the plug that you check.
 - ★ Plug: 1/8NPTF
 1. Forward clutch pressure measuring outlet
 2. Reverse clutch pressure measuring outlet
 3. 1st speed clutch pressure measuring outlet
 4. 2nd speed clutch pressure measuring outlet
 5. 3rd speed clutch pressure measuring outlet

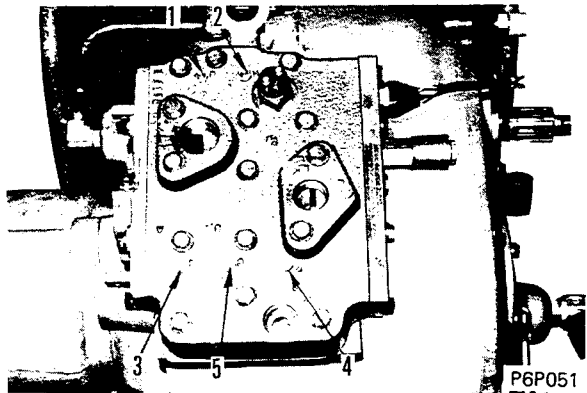

2. Install an oil pressure gauge (max. pressure 25 kg/cm²)
3. Start the engine and operate that torque converter oil temperature come to 75 ~ 90°C.

Checking item No. 1 ~ 6

4. Make torque converter stalling and check above oil pressure.
 - ★ When checking the clutch pressure you need, set transmission control lever to the necessary range.

Checking item No. 7

4. Make engine high idling, and check above oil pressure.

No.	Pressure point	Oil pressure (kg/cm ²)	Measuring conditions
1	Forward clutch pressure	22 ~ 25	Torque converter stall Engine at full output Torque converter oil temperature 80 to 100°C
2	Reverse clutch pressure		
3	1st speed clutch pressure		
4	2nd speed clutch pressure		
5	3rd speed clutch pressure		
6	Torque converter pressure	1.95 ~ 2.25	
7	Lubrication pressure	0.6 ~ 2	

DISASSEMBLY AND ASSEMBLY

ENGINE AND TORQUE CONVERTER ASSEMBLY

- Removal 23- 4
- Installation 23- 8

TORQUE CONVERTER AND PUMP ASSEMBLY

- Removal 23-12
- Installation 23-15

TORQUE CONVERTER

- Disassembly 23-18
- Assembly 23-23

TORQUE CONVERTER CHARGING PUMP

- Removal 23-30
- Installation 23-31
- Disassembly 23-32
- Assembly 23-34

TRANSMISSION ASSEMBLY

- Removal 23-36
- Installation 23-39
- Disassembly 23-44
- Assembly 23-48

CLUTCH PACK

- Disassembly 23-58
- Assembly 23-61

TRANSMISSION CONTROL VALVE

- Disassembly 23-74
- Assembly 23-75

FRONT AXLE

- Removal 23-81
- Installation 23-81

REAR AXLE

- Removal 23-81
- Installation 23-81

DIFFERENTIAL

- Removal 23-82
- Installation 23-83
- Disassembly 23-84
- Assembly 23-87

PLANETARY CARRIER

- Disassembly 23-94
- Assembly 23-96

TRANSFER DRIVE

- Removal 23-102
- Installation 23-103
- Disassembly 23-104
- Assembly 23-105

DRIVE SHAFT

- Disassembly 23-107
- Assembly 23-108
- Tightening torque 23-108