

AUTOMATIC TRANSMISSION / TRANSAXLE (U150E) COMPONENTS

400GZ-01

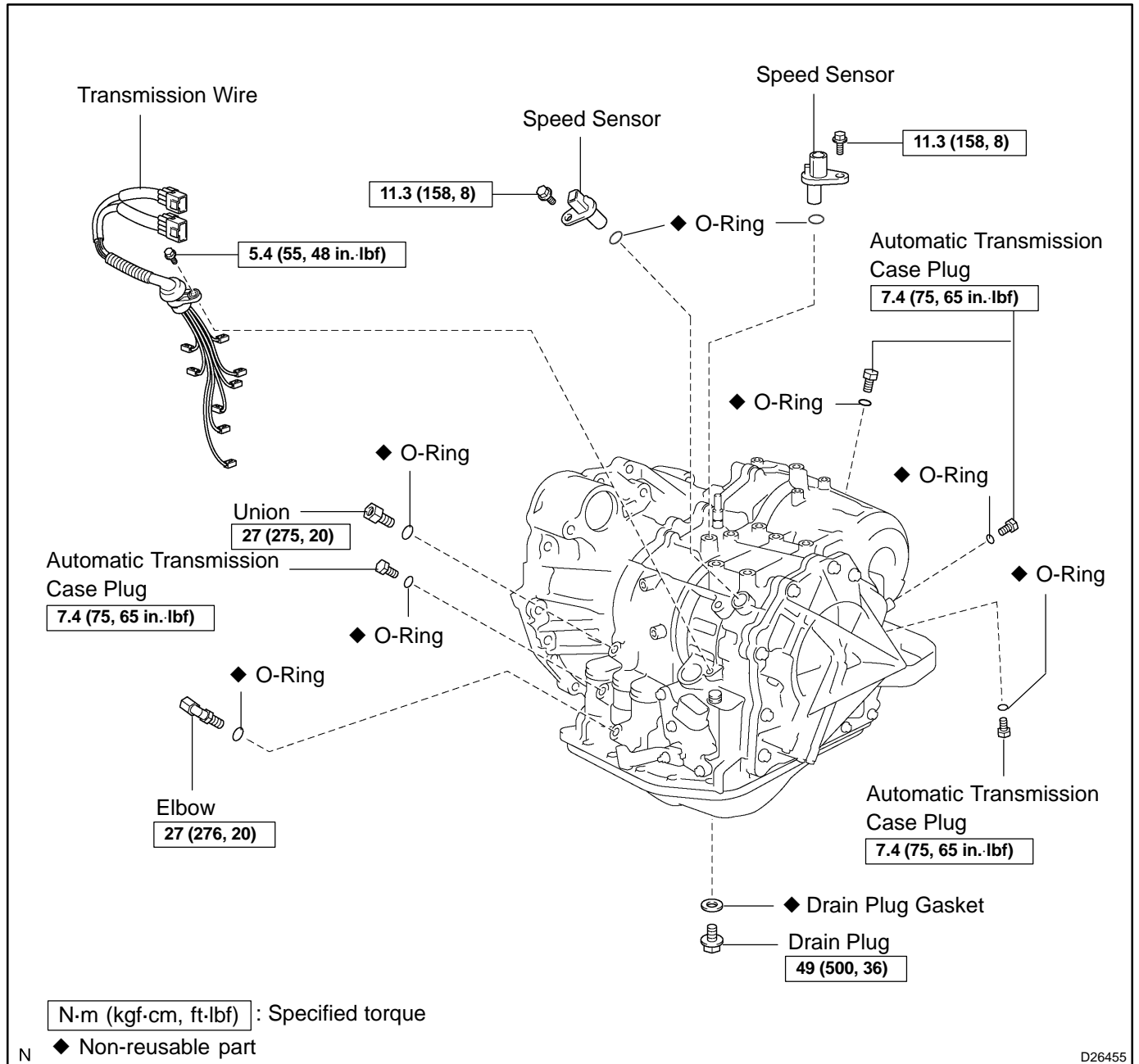

D26455

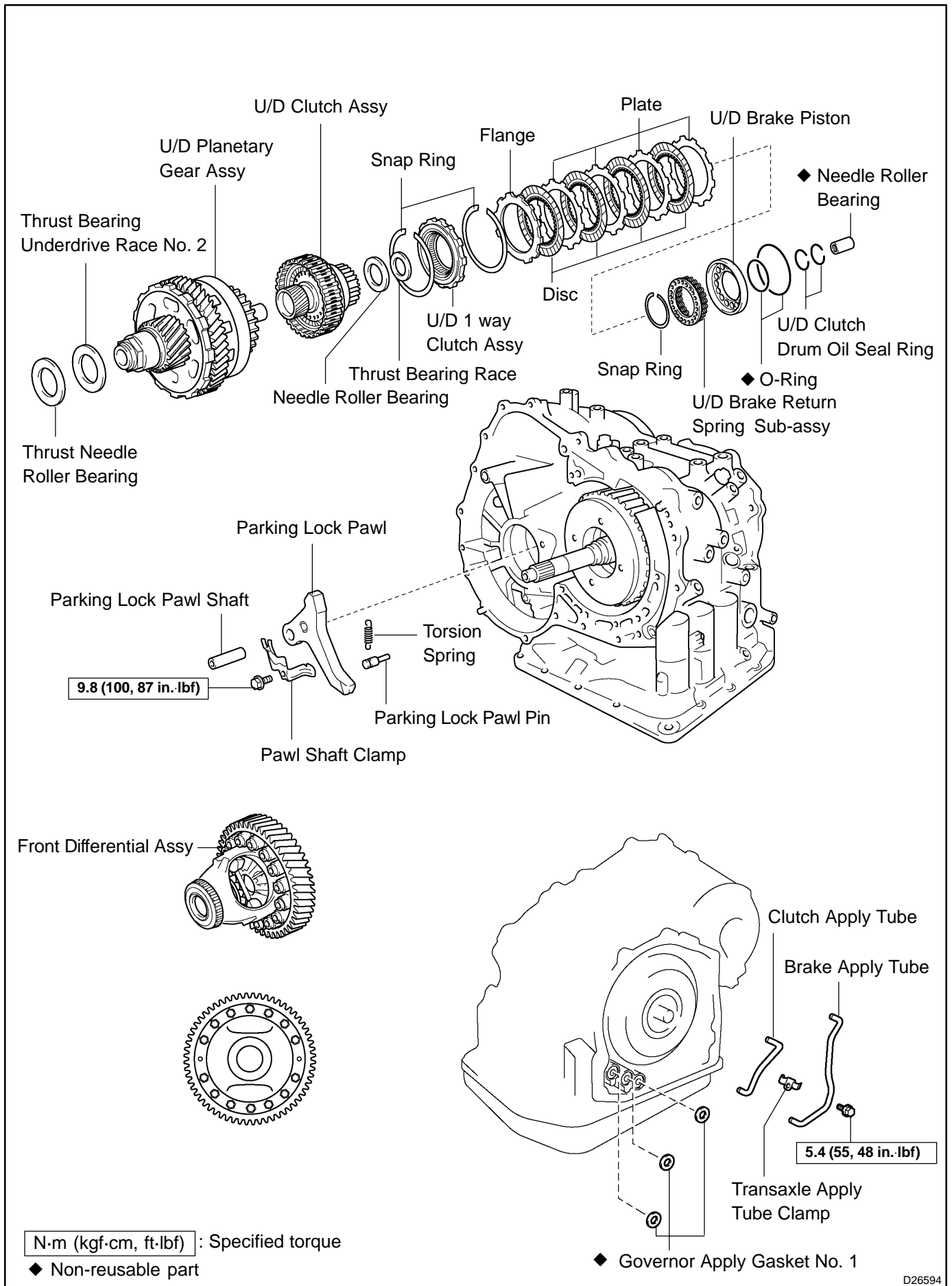

D26594

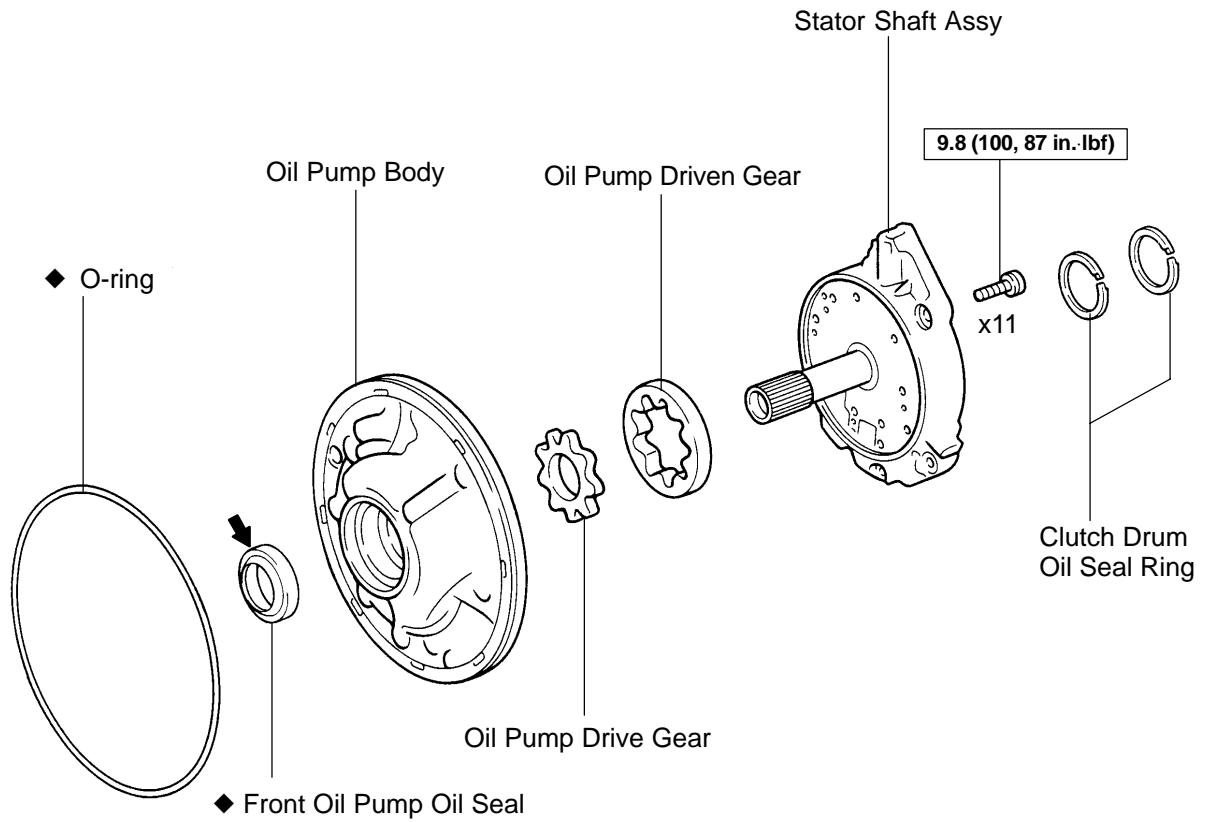

N·m (kgf·cm, ft·lbf) : Specified torque

- ◆ Non-reusable part
- ◀ Apply petroleum jelly

D03643

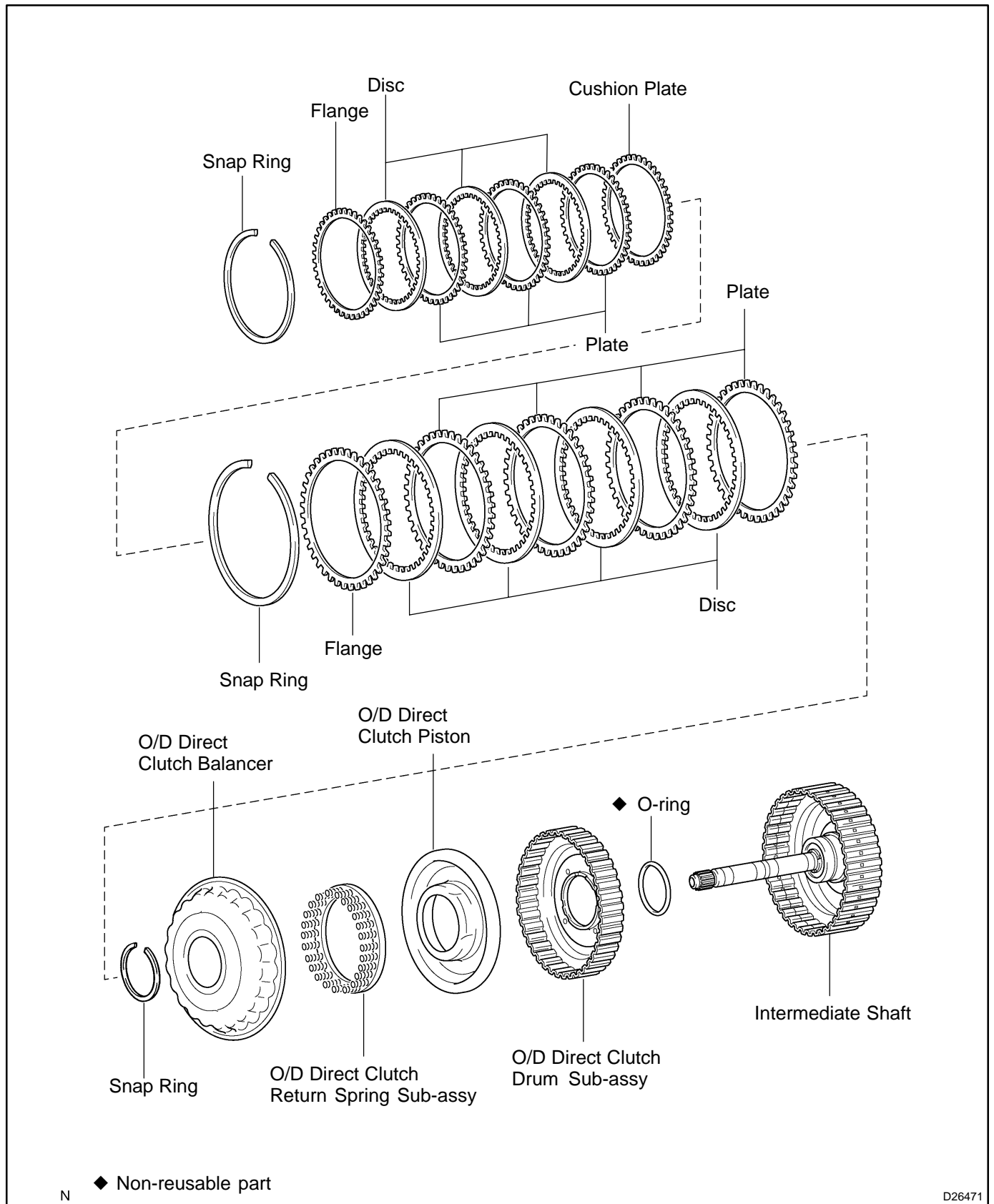

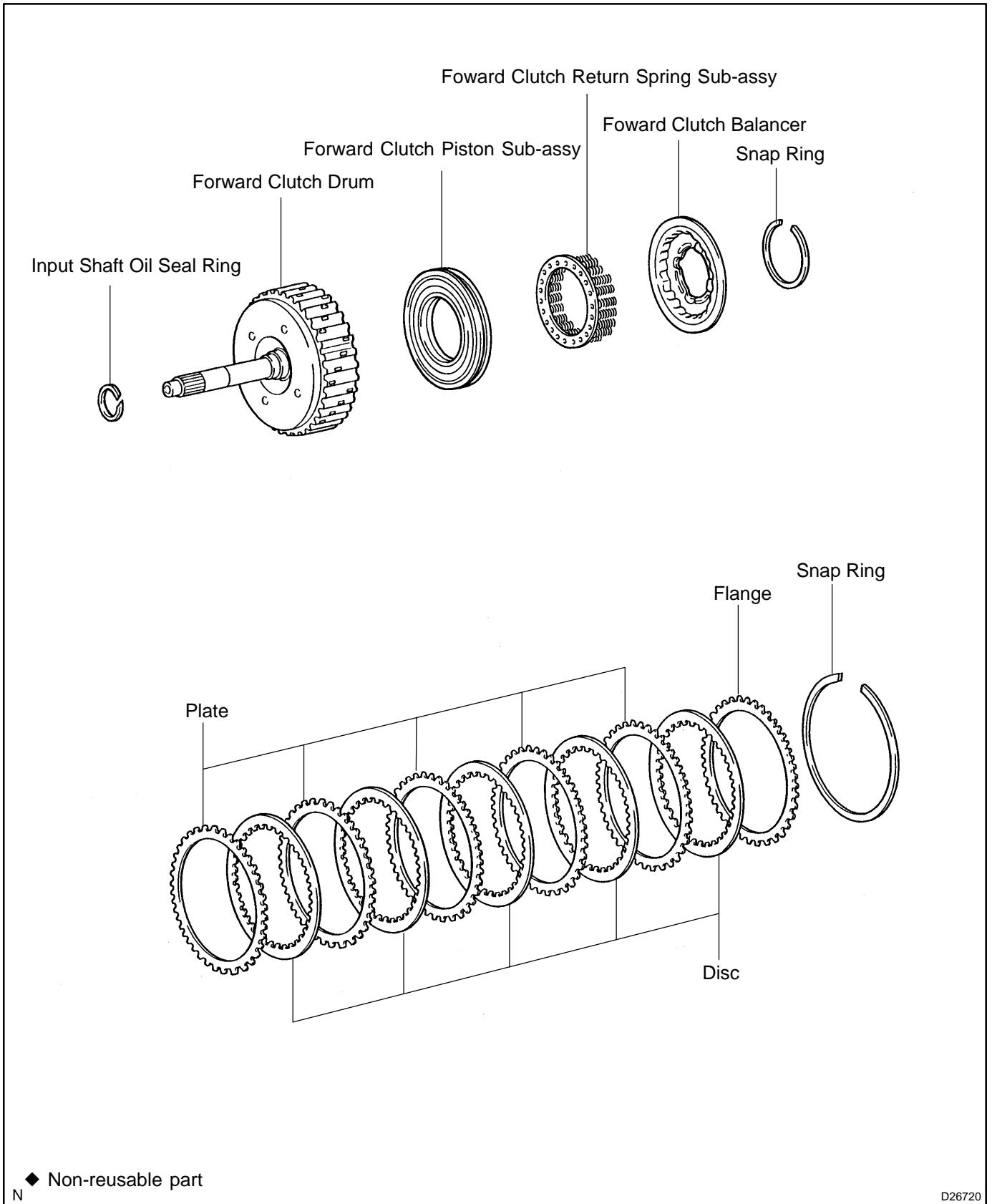

◆ Non-reusable part

D26720

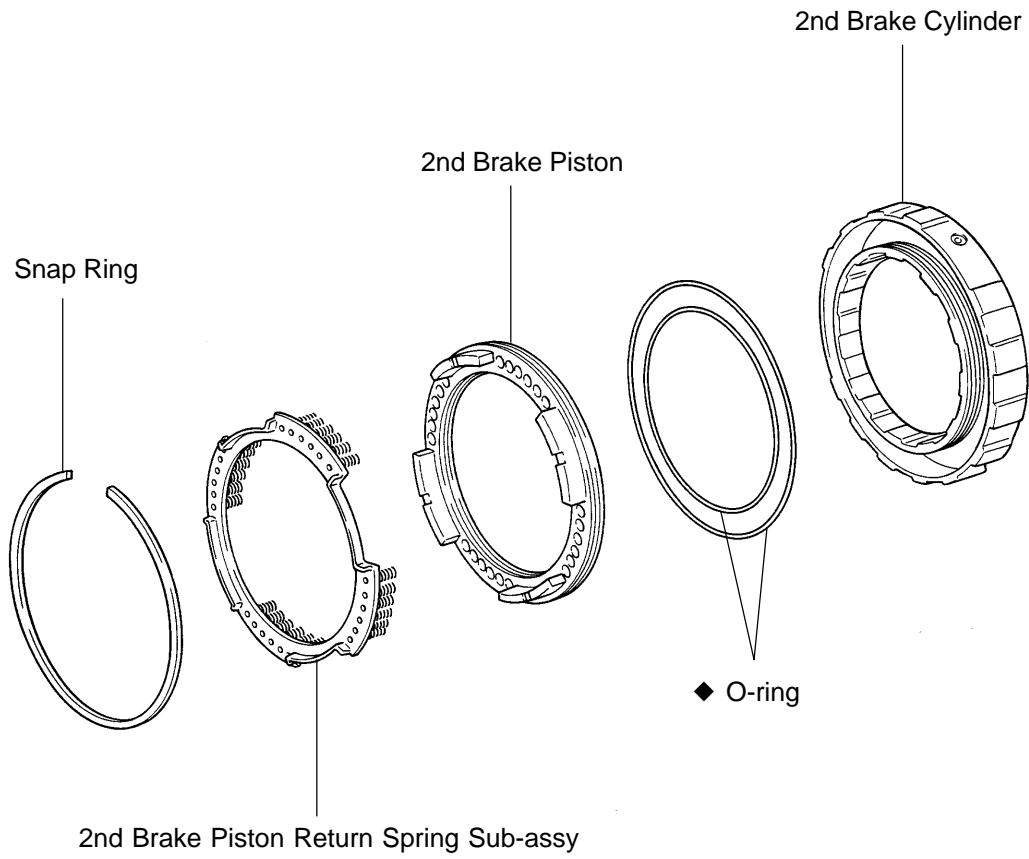

◆ Non-reusable part

N

D26702

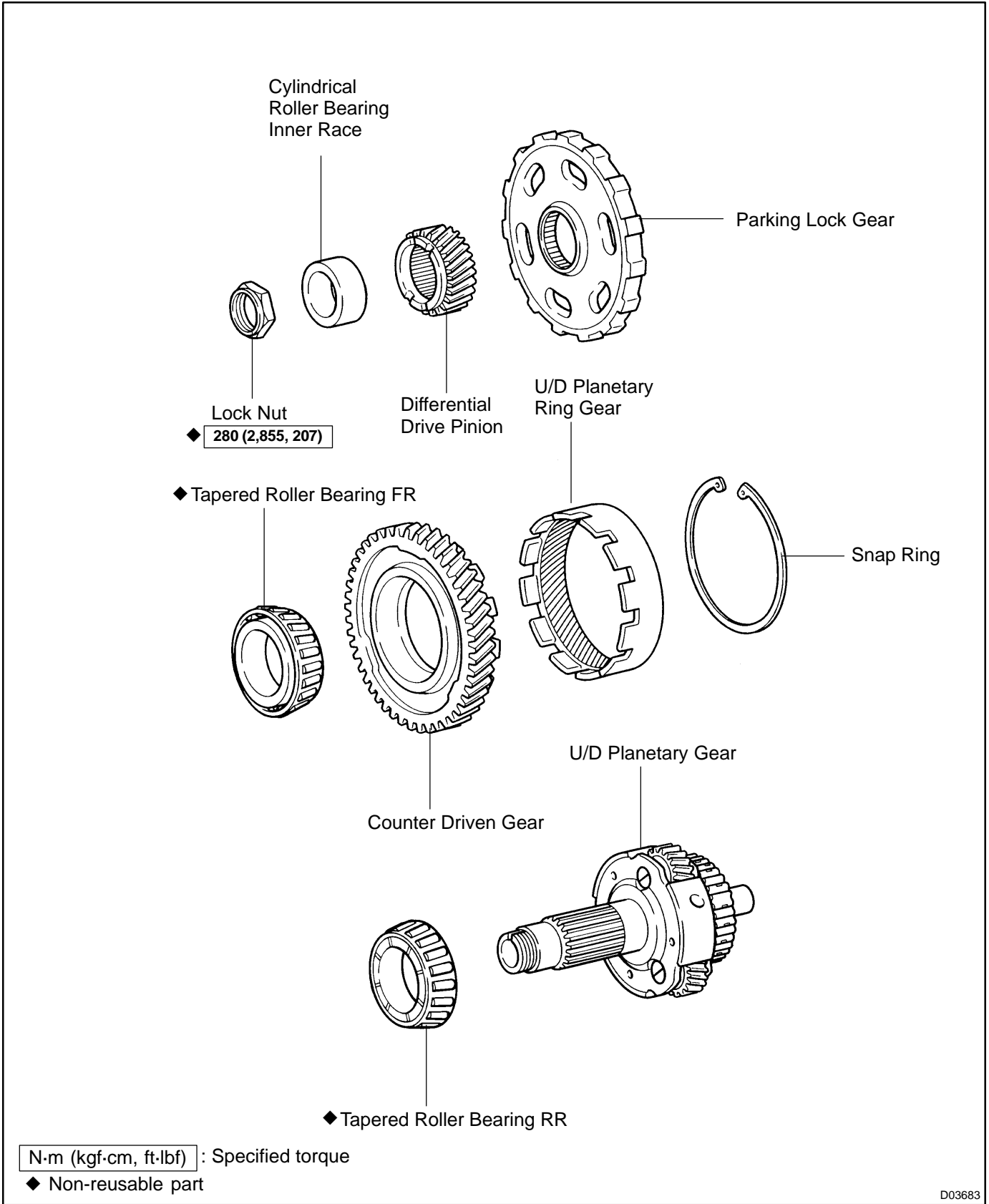

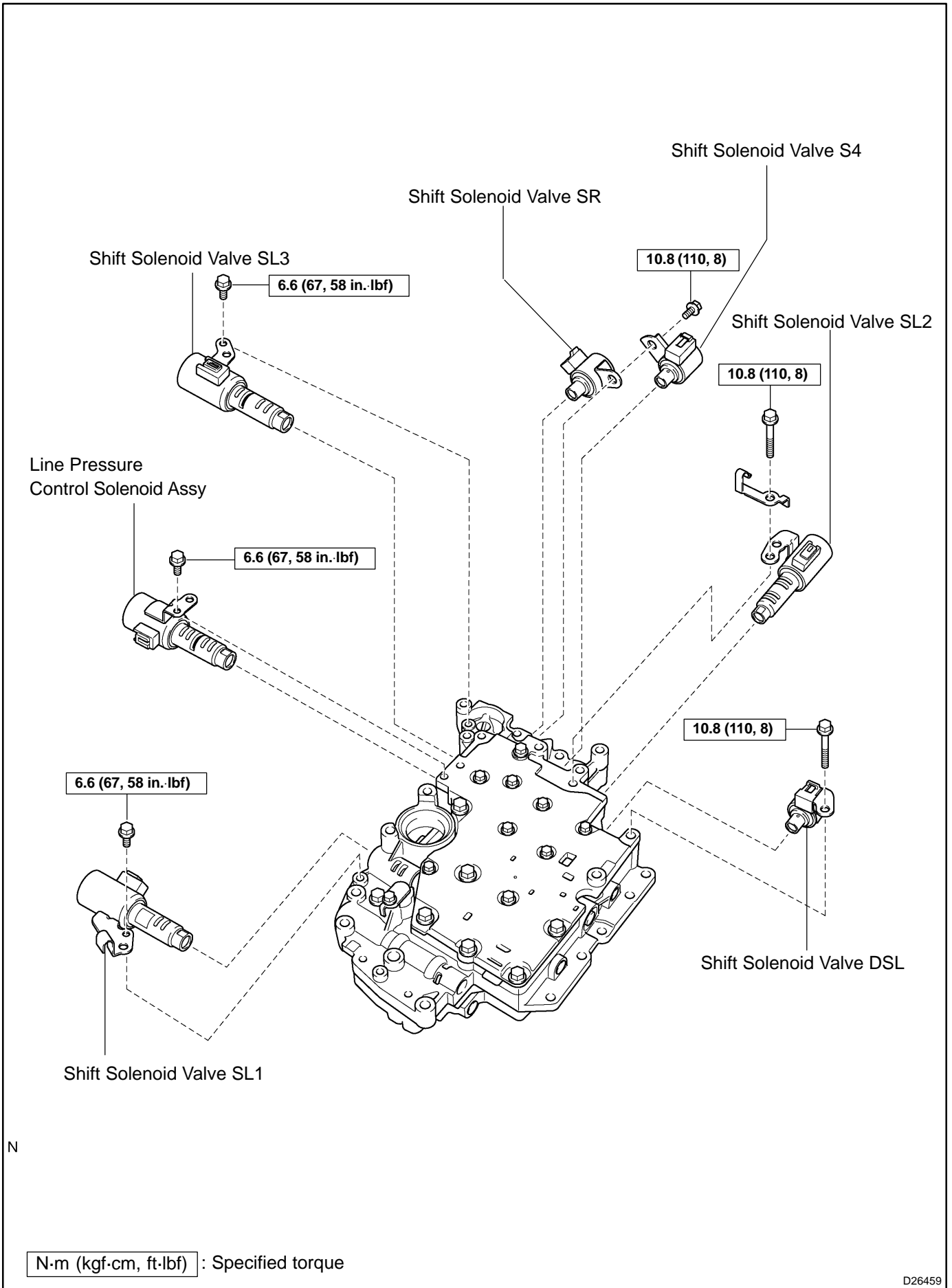

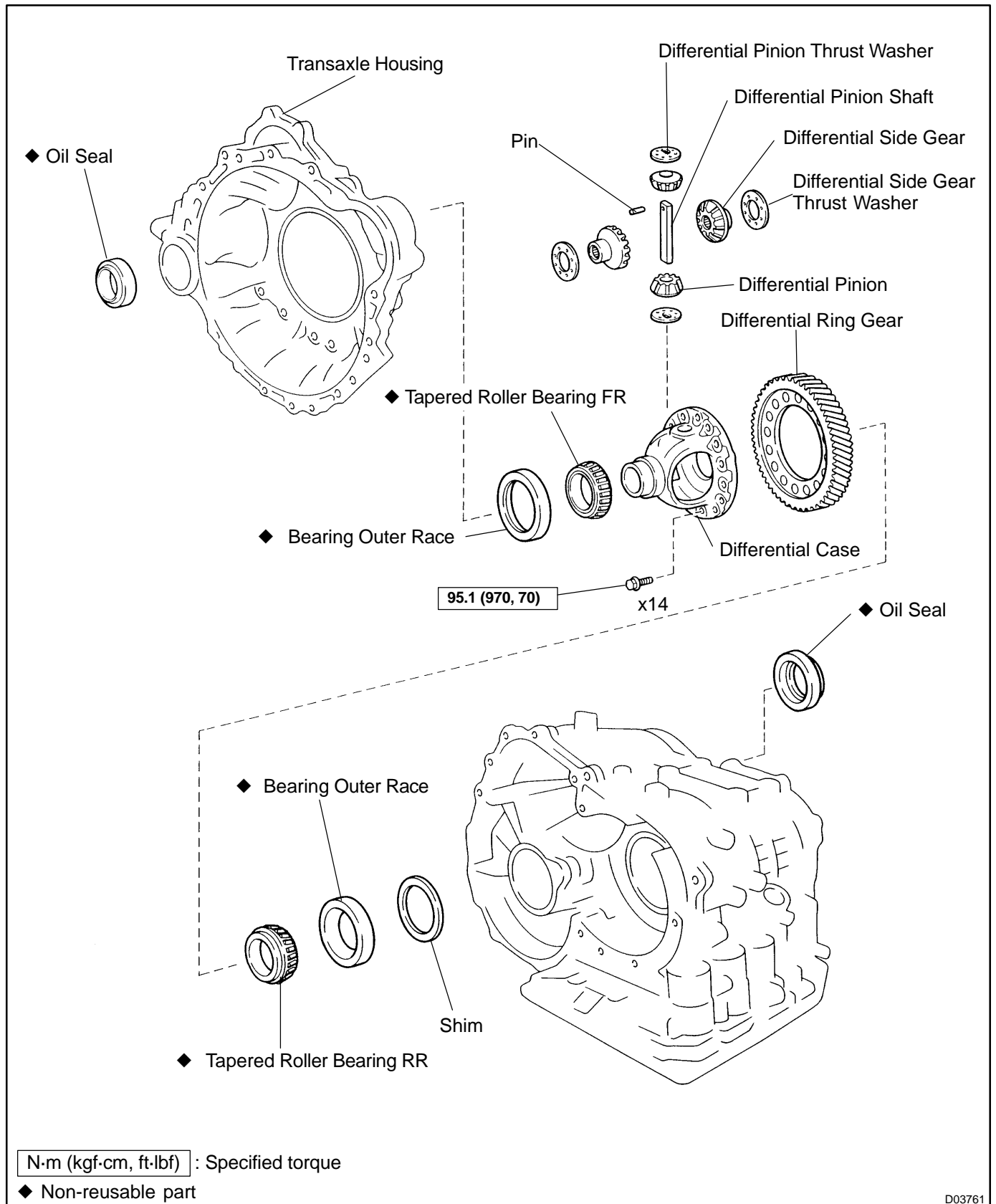

D03761