

2014 STEERING

Power Steering System (Service Information) - IS250-IS350

POWER STEERING ECU

COMPONENTS [04/2013 -]

ILLUSTRATION

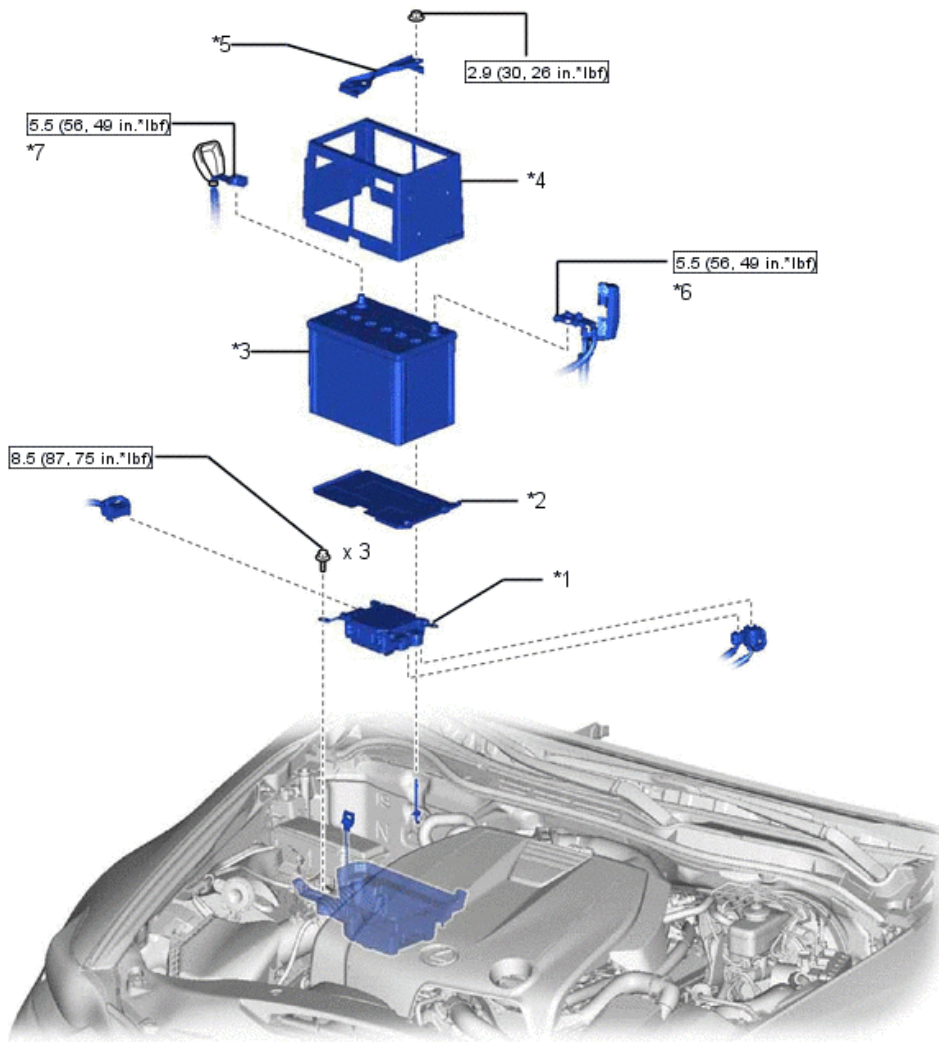

H

Fig. 1: Identifying Power Steering ECU Replacement Components With Torque Specifications
 Courtesy of TOYOTA MOTOR SALES, U.S.A., INC.

*1	POWER STEERING ECU	*2 NO. 1 BATTERY TRAY
----	--------------------	-----------------------

2014 Lexus IS 350

2014 STEERING Power Steering System (Service Information) - IS250-IS350

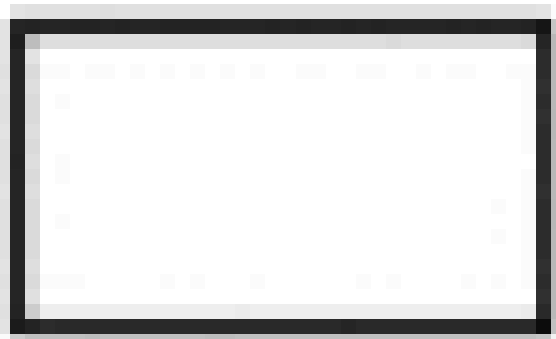
	ASSEMBLY		SUPPORT
*3	BATTERY	*4	BATTERY INSULATOR
*5	BATTERY CLAMP	*6	POSITIVE BATTERY TERMINAL
*7	NEGATIVE BATTERY TERMINAL	-	-
			
	N*m (kgf*cm, ft.*lbf): Specified torque	-	-

REMOVAL [04/2013 -]

PROCEDURE

1. PRECAUTION

Refer to **PRECAUTION [04/2013 -]**

2. DISCONNECT CABLE FROM NEGATIVE BATTERY TERMINAL

NOTE:

- After turning the engine switch off, waiting time may be required before disconnecting the cable from the negative (-) battery terminal.

Therefore, make sure to read the disconnecting the cable from the negative (-) battery terminal notices before proceeding with work.

Refer to **PRECAUTION [04/2013 -]**

- When disconnecting the cable, some systems need to be initialized after the cable is reconnected.

Refer to **INITIALIZATION [04/2013 -]**

- a. Loosen the nut, and disconnect the cable from the negative (-) battery terminal.

3. REMOVE BATTERY

- a. Disengage the 2 claws and separate the center No. 1 cowl top ventilator louver.

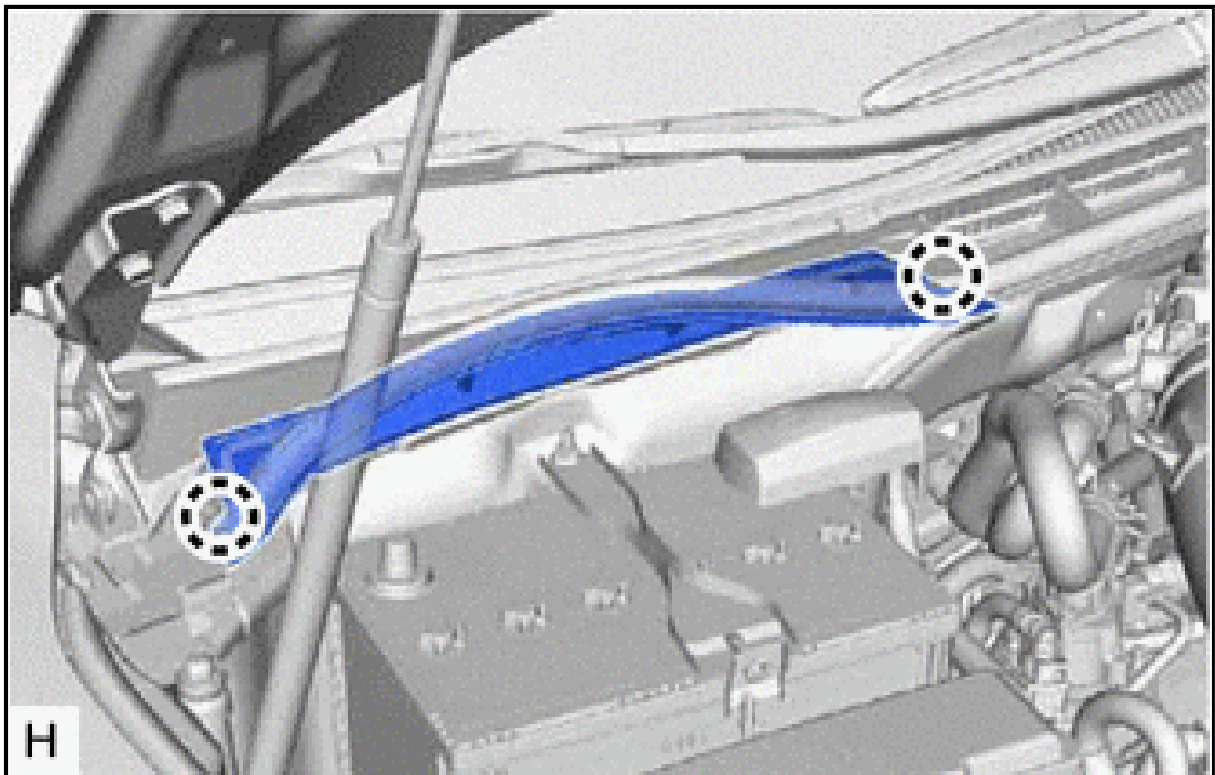

- b. Disconnect the 2 harness clamps.

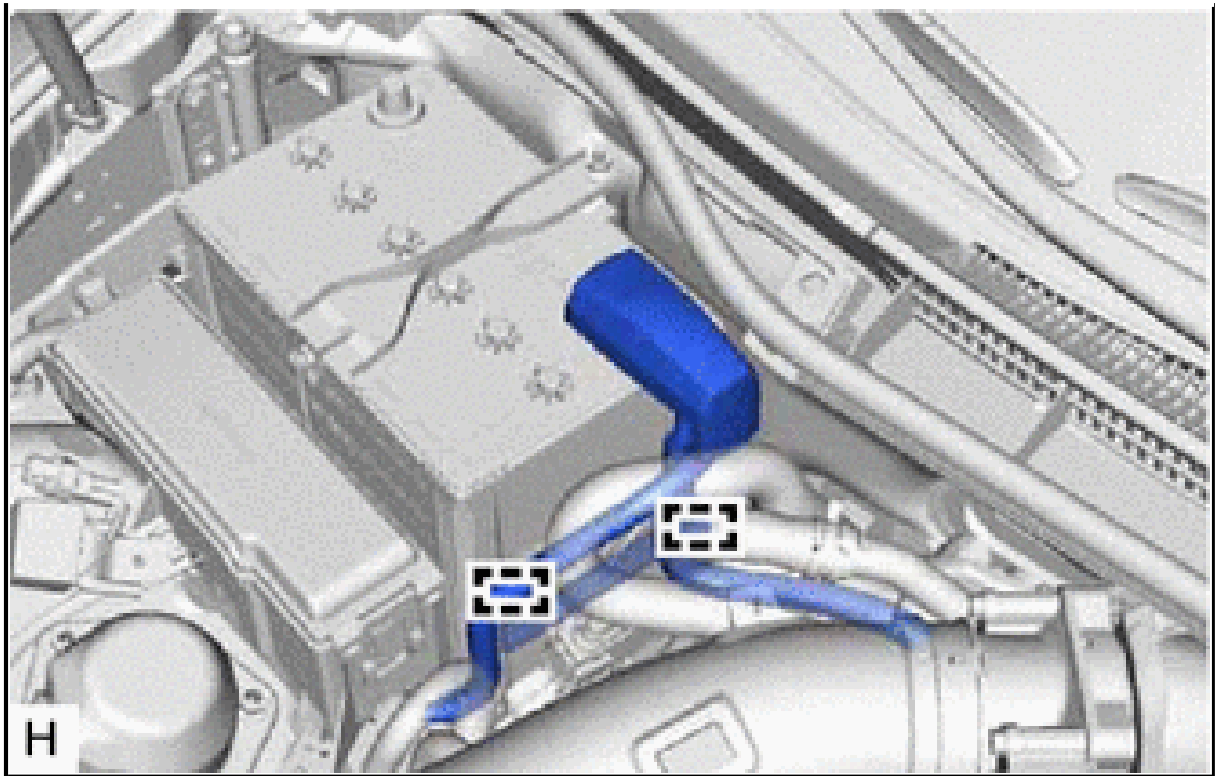

- c. Loosen the nut, and disconnect the cable from the positive (+) battery terminal.
 - d. Remove the nut and battery clamp.
 - e. Remove the battery insulator.
 - f. Remove the battery.
4. **REMOVE NO. 1 BATTERY TRAY SUPPORT**
 - a. Remove the No. 1 battery tray support.
 5. **REMOVE POWER STEERING ECU ASSEMBLY**
 - a. Remove the 3 bolts.

2014 Lexus IS 350

2014 STEERING Power Steering System (Service Information) - IS250-IS350

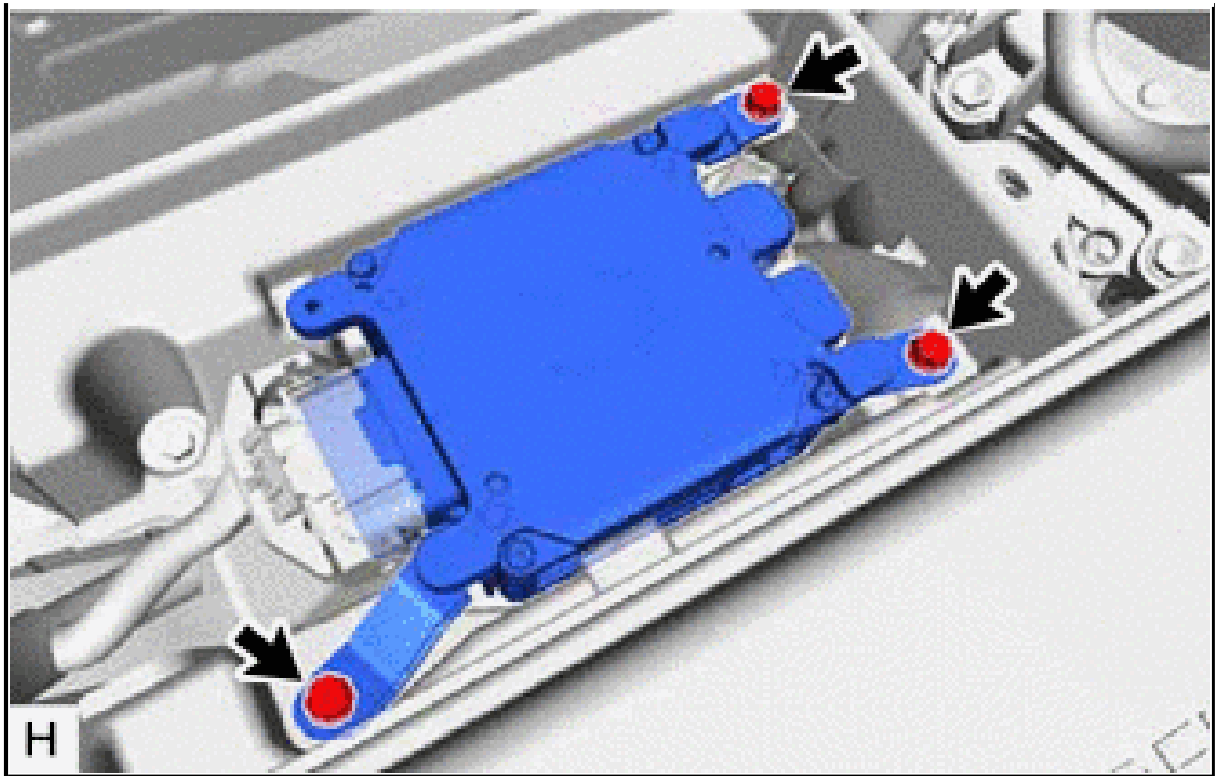

- b. Disconnect the 3 connectors from the power steering ECU assembly and remove the power steering ECU assembly.

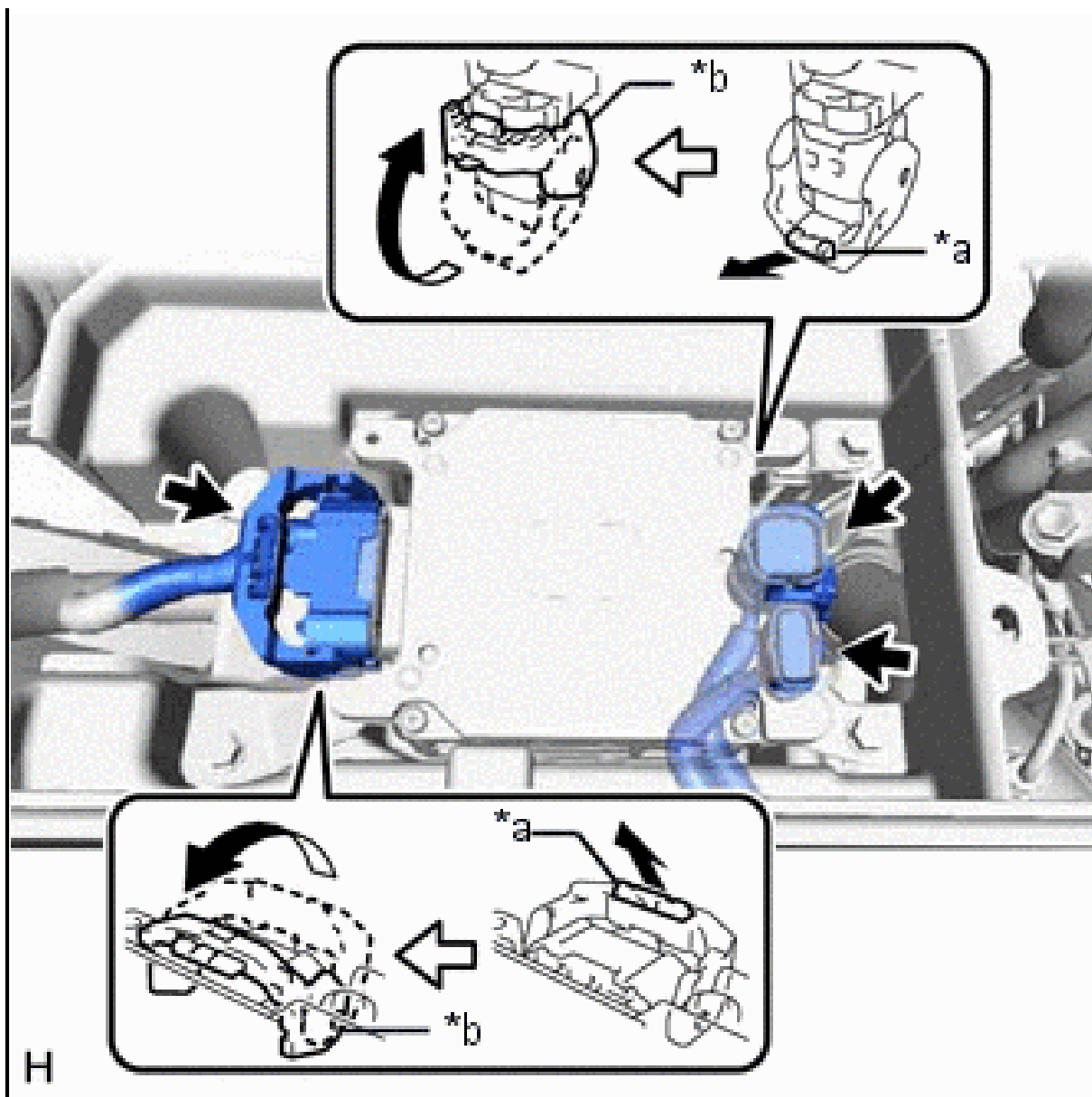

*a	Lock of the Lock Lever
*b	Lock Lever

HINT:

When disconnecting the connector with lock lever, as shown in the illustration, pull out the lock of the lock lever and turn the lock lever to disconnect the connector.

INSTALLATION [04/2013 -]

PROCEDURE

1. INSTALL POWER STEERING ECU ASSEMBLY

- a. Connect the 3 connectors to the power steering ECU assembly.

HINT:

When connecting the connector with lock lever, as shown in the illustration, return the lock lever to its original position to connect the connector and securely push in the lock of the lock lever.

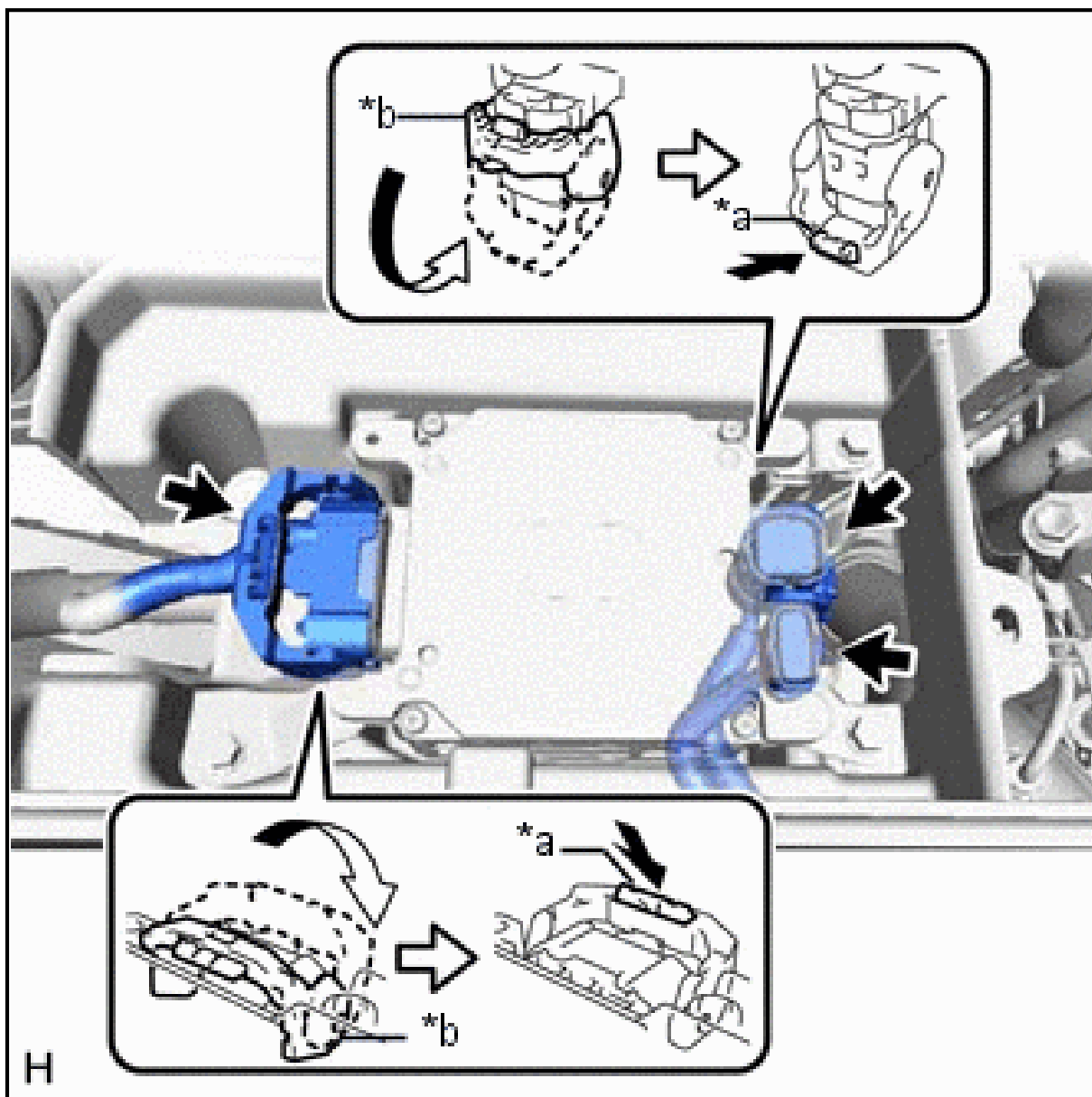

*a	Lock of the Lock Lever
*b	Lock Lever

- b. Install the power steering ECU assembly to the battery tray with the 3 bolts.

Torque: 8.5 N*m (87 kgf*cm, 75 in.*lbf)

2. INSTALL NO. 1 BATTERY TRAY SUPPORT

- a. Install the No. 1 battery tray support.

3. INSTALL BATTERY

- a. Install the battery and battery insulator.
- b. Connect the 2 harness clamps.
- c. Install the battery clamp with the nut.

Torque: 2.9 N*m (30 kgf*cm, 26 in.*lbf)

- d. Connect the cable to the positive (+) battery terminal and tighten the nut.

Torque: 5.5 N*m (56 kgf*cm, 49 in.*lbf)

- e. Engage the 2 claws to install the center No. 1 cowl top ventilator louver.

4. CONNECT CABLE TO NEGATIVE BATTERY TERMINAL

- a. Connect the cable to the negative (-) battery terminal and tighten the nut.

Torque: 5.5 N*m (56 kgf*cm, 49 in.*lbf)

NOTE: When disconnecting the cable, some systems need to be initialized after the cable is reconnected.

Refer to INITIALIZATION [04/2013 -]

5. ROTATION ANGLE SENSOR INITIALIZATION AND TORQUE SENSOR ZERO POINT CALIBRATION

Refer to CALIBRATION [04/2013 -]

6. ASSIST MAP WRITING

Refer to CALIBRATION [04/2013 -]

RELAY

ON-VEHICLE INSPECTION [04/2013 -]

PROCEDURE

1. INSPECT EPS RELAY (ELECTRIC POWER STEERING RELAY)

2014 Lexus IS 350

2014 STEERING Power Steering System (Service Information) - IS250-IS350

- a. Measure the resistance according to the value(s) in the table below.

Standard Resistance

Tester Connection	Condition	Specified Condition
5 - 3	Voltage not applied between terminals 1 and 2	10 kohms or higher
5 - 3	Voltage applied between terminals 1 and 2	Below 1 ohms
1 - 3	Voltage not applied between terminals 1 and 2	10 kohms or higher
2 - 5	Voltage not applied between terminals 1 and 2	10 kohms or higher
1 - 2	Voltage not applied between terminals 1 and 2	180 to 220 ohms

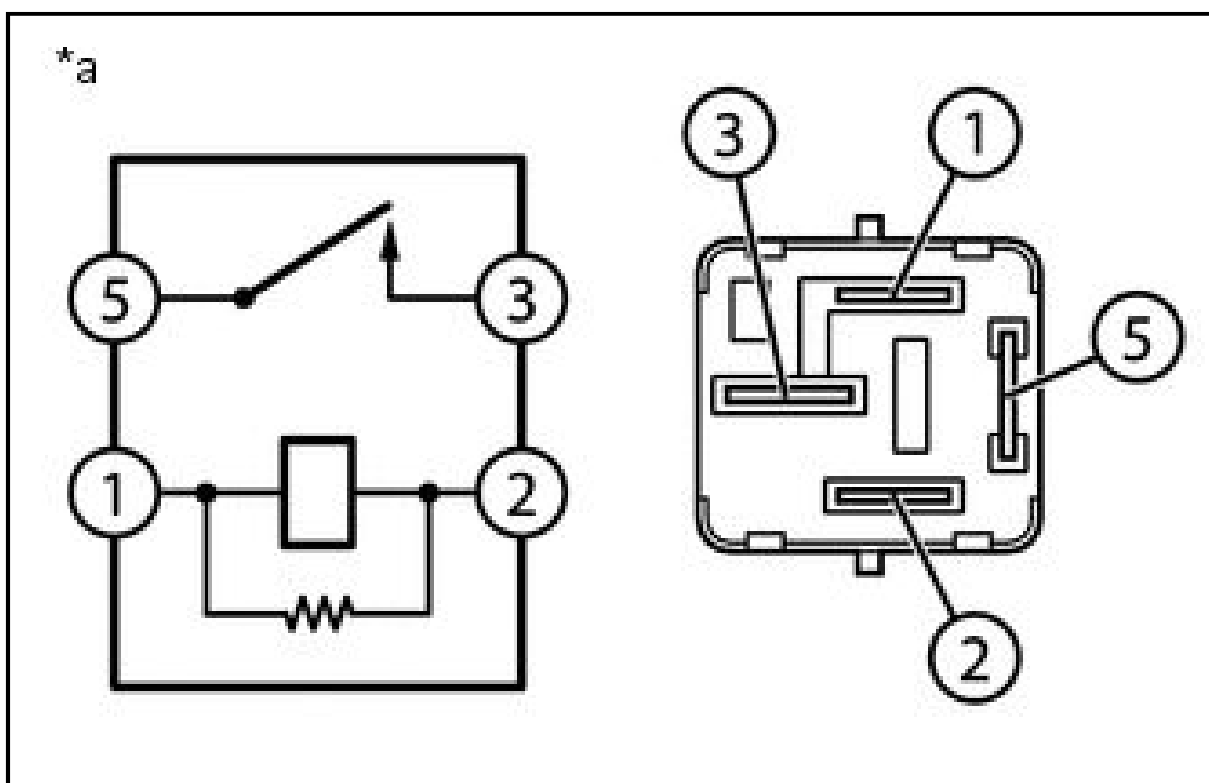

*a

EPS Relay (Electric Power Steering Relay)