

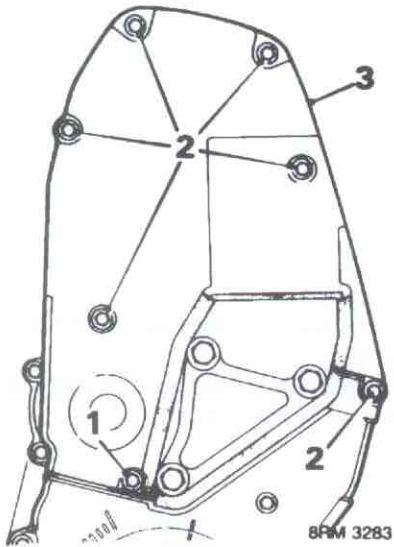

CAMSHAFT TIMING BELT - K8 ENGINES

Remove



1. Slacken bottom bolt securing timing belt upper front cover.

NOTE: Remove bottom bolt when cover is not slotted.

2. Remove 6 bolts from timing belt upper front cover.
3. Remove timing belt upper front cover and seal.

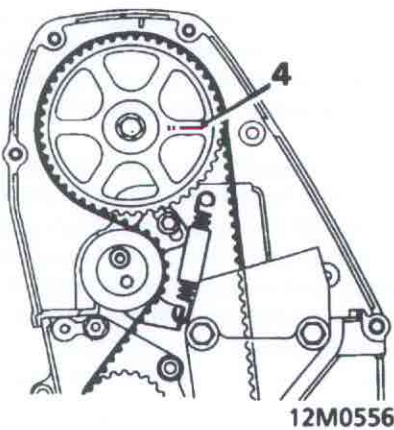

4. Rotate crankshaft clockwise to align camshaft gear timing marks with top face of cylinder head - 90° BTDC.



CAUTION: Do not use camshaft gear, gear retaining bolt or timing belt to rotate crankshaft.

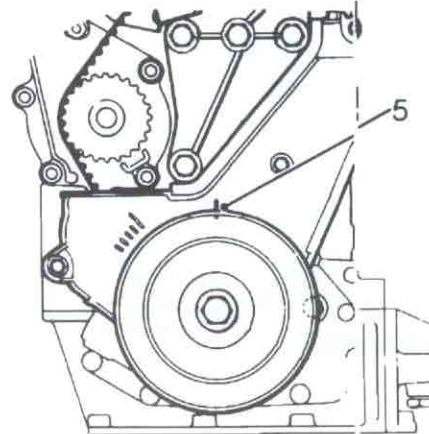

5. Check that timing mark on crankshaft pulley is aligned with mark on timing belt lower cover.

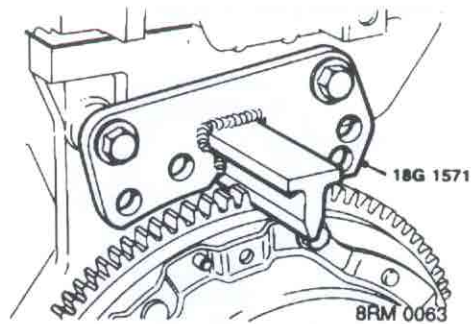

6. Position flywheel locking tool 18G 1571 to flywheel.
7. Secure with 2 bolts.

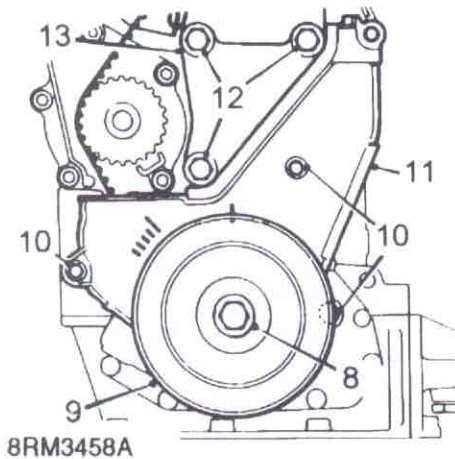

8. Remove crankshaft pulley bolt and washer.
9. Remove crankshaft pulley.
10. Remove 3 bolts securing timing belt lower cover.
11. Remove timing belt lower cover together with seals.
12. Remove 3 bolts, mounting bracket to engine.
13. Remove mounting bracket.

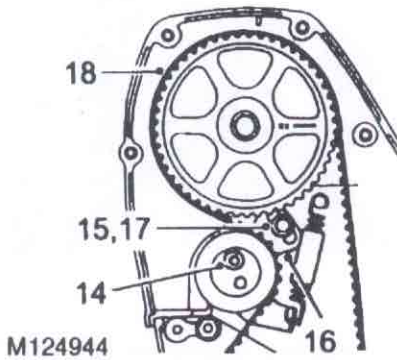

14. Slacken tensioner pulley Allen screw.
15. Slacken tensioner backplate screw.
16. Push tensioner pulley down to fully OFF position.
17. Tighten backplate screw to 10 Nm.
18. Ease timing belt from gears using the fingers only.
19. Discard timing belt.

CAUTION: Timing belt must always be replaced during engine overhaul. Do not rotate crankshaft with timing belt removed and cylinder head fitted.

Refit

1. Clean timing gears, coolant pump drive gear and tensioner pulley .



CAUTION: If the sintered gears have been subjected to prolonged contamination, they must be soaked in a solvent bath and then thoroughly washed in clean solvent before refitting. Because of the porous construction of sintered material, oil impregnated in the gears will emerge and contaminate the belt.

2. Check correct alignment of timing marks for 90° BTDC:
Crankshaft gear dots align with flange on oil pump.
Camshaft gear mark to right aligns with top face of cylinder head.

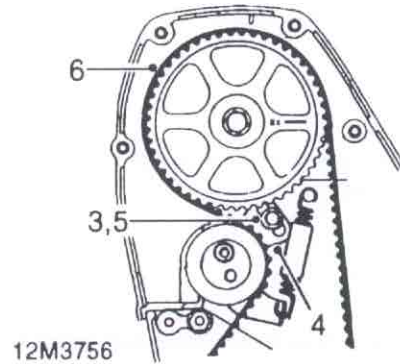

3. Slacken tensioner backplate screw, ensure tensioner moves fully through its adjustment range and returns under spring tension.
4. Push tensioner pulley down to fully OFF position.
5. Tighten backplate screw to 10 Nm.
6. Using the fingers only, fit a new timing belt over crankshaft timing gear, camshaft gear, tensioner pulley and coolant pump drive gear, ensure belt is positioned centrally on gears and pulley and that any slack in the belt is on the tensioner pulley side of the belt.
7. Clean all traces of Loctite from engine mounting bracket securing bolts and apply Loctite 542 to threads of bolts.
8. Fit engine mounting bracket, tighten bolts to 45 Nm.



9. Ensure inserts are fitted in timing belt lower cover.
10. Fit timing belt lower cover, ensuring correct position of seals, tighten screws to 10 Nm.

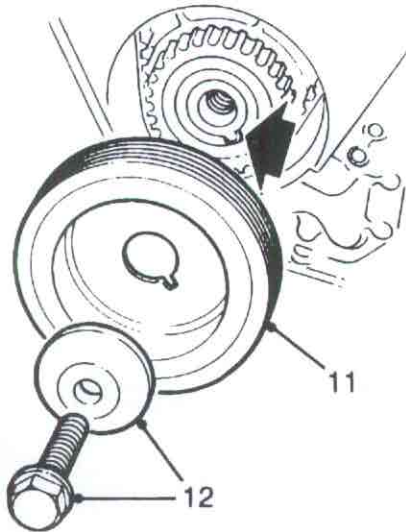

12M3757

11. Fit crankshaft pulley to crankshaft timing gear ensuring that indent on pulley locates over gear lug (arrowed).
12. Fit crankshaft pulley bolt and washer, tighten to 205 Nm.
13. Remove flywheel locking tool 18G 1571.

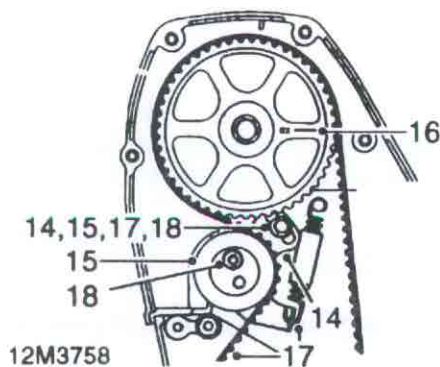

12M3758

14. Slacken tensioner backplate screw and tension timing belt by applying finger pressure to tensioner backplate.

15. With tensioner pulley against timing belt and backplate held in position, tighten backplate screw to 10 Nm.
16. Rotate crankshaft clockwise 2 complete revolutions and align camshaft gear timing mark with top face of cylinder head.



CAUTION: Do not use camshaft gear, gear retaining bolt or timing belt to rotate crankshaft.

17. Slacken tensioner backplate screw and check that belt is being tensioned by the tensioner spring.
18. Tighten tensioner backplate screw to 10 Nm and tensioner pulley Allen screw to 45 Nm.
19. Ensure inserts are fitted in timing belt upper front cover.
20. Fit timing belt upper front cover, ensuring correct position of seals, tighten screws and bolt to 5 Nm.