Table of Contents

Foreword.....	1
Service Diagnosis.....	2
Safety Information.....	3
Engine Systems.....	5
Mounting Engine on Engine Stand.....	55
Engine Electrical.....	65
Variable Geometry Turbocharger (VGT).....	107
Exhaust Gas Recirculation (EGR) System.....	119
Intake, Inlet, and Exhaust Manifolds.....	141
Fuel and High-pressure Oil Systems.....	155
Diamond Logic® Engine Brake.....	185
Air Compressor and Power Steering Pump.....	201
Oil System Module Assembly.....	213
Oil Pan and Oil Suction Tube.....	231
Front Cover, Cooling System, and Related Components.....	243
Cylinder Head and Valve Train.....	291
Flywheel and Flywheel Housing.....	337
Power Cylinders.....	365
Crankcase, Crankshaft, and Camshaft.....	403
Abbreviations and Acronyms.....	443
Terminology.....	449
Appendix A - Specifications.....	457
Appendix B - Torques.....	475

Appendix C - Special Service Tools.....487

Foreword

Navistar, Inc. is committed to continuous research and development to improve products and introduce technological advances. Procedures, specifications, and parts defined in published technical service literature may be altered.

This *Service Manual* provides a general sequence of procedures for out-of-chassis engine overhaul (removal, inspection, and installation). For in-chassis service of parts and assemblies, the sequence may vary.

NOTE: Photo illustrations identify specific parts or assemblies that support text and procedures; other areas in photo illustrations may not be exact.

See vehicle manuals and Technical Service Information (TSI) bulletins for additional information.

Technical Service Literature

1171939R3	MaxxForce®DT, 9, and 10 <i>Engine Operation and Maintenance Manual</i>
EGES-335-1	MaxxForce®DT, 9, and 10 <i>Engine Service Manual</i>
EGES-370-1	MaxxForce®DT, 9, and 10 <i>Engine Diagnostic Manual</i>
EGED-375	MaxxForce® DT, 9, and 10 Hard Start/ No Start Diagnostic Form
EGED-380	MaxxForce® DT, 9, and 10 Performance Diagnostic Form
EGED-385	MaxxForce® DT, 9, and 10 Electronic Control Systems Form

Technical Service Literature is revised periodically and mailed automatically to "Revision Service" subscribers. If a technical publication is ordered, the latest revision will be supplied.

NOTE: To order technical service literature, contact your Navistar dealer.

Service Diagnosis

Service diagnosis is an investigative procedure that must be followed to find and correct an engine application problem or an engine problem.

If the problem is engine application, see specific vehicle manuals for further diagnostic information.

If the problem is the engine, see specific *Engine Diagnostic Manual* for further diagnostic information.

Prerequisites for Effective Diagnosis

- Availability of gauges and diagnostic test equipment
- Availability of current information for engine application and engine systems

- Knowledge of the principles of operation for engine application and engine systems
- Knowledge to understand and do procedures in diagnostic and service publications

Technical Service Literature required for Effective Diagnosis

- *Engine Service Manual*
- *Engine Diagnostic Manual*
- Diagnostics Forms
- Electronic Control Systems Diagnostics Forms
- Service Bulletins

Safety Information

This manual provides general and specific service procedures essential for reliable engine operation and your safety. Since many variations in procedures, tools, and service parts are involved, advice for all possible safety conditions and hazards cannot be stated.

Read safety instructions before doing any service and test procedures for the engine or vehicle. See related application manuals for more information.

Disregard for Safety Instructions, Warnings, Cautions, and Notes in this manual can lead to injury, death or damage to the engine or vehicle.

SAFETY TERMINOLOGY

Three terms are used to stress your safety and safe operation of the engine: Warning, Caution, and Note

Warning: A warning describes actions necessary to prevent or eliminate conditions, hazards, and unsafe practices that can cause personal injury or death.

Caution: A caution describes actions necessary to prevent or eliminate conditions that can cause damage to the engine or vehicle.

Note: A note describes actions necessary for correct, efficient engine operation.

SAFETY INSTRUCTIONS

Vehicle

- Make sure the vehicle is in neutral, the parking brake is set, and the wheels are blocked before doing any work or diagnostic procedures on the engine or vehicle.

Work area

- Keep work area clean, dry, and organized.
- Keep tools and parts off the floor.
- Make sure the work area is ventilated and well lit.
- Make sure a first aid kit is available.

Safety equipment

- Use correct lifting devices.
- Use safety blocks and stands.

Protective measures

- Wear protective safety glasses and shoes.
- Wear correct hearing protection.
- Wear cotton work clothing.
- Wear sleeved heat protective gloves.
- Do not wear rings, watches or other jewelry.
- Restrain long hair.

Fire prevention

- Make sure charged fire extinguishers are in the work area.

NOTE: Check the classification of each fire extinguisher to ensure that the following fire types can be extinguished.

1. Type A — Wood, paper, textiles, and rubbish
2. Type B — Flammable liquids
3. Type C — Electrical equipment

Batteries

Batteries produce highly flammable gas during and after charging.

- Always disconnect the main negative battery cable first.
- Always connect the main negative battery cable last.
- Avoid leaning over batteries.
- Protect your eyes.
- Do not expose batteries to open flames or sparks.
- Do not smoke in workplace.

Compressed air

- Limit shop air pressure for blow gun to 207 kPa (30 psi).
- Use approved equipment.
- Do not direct air at body or clothing.
- Wear safety glasses or goggles.
- Wear hearing protection.
- Use shielding to protect others in the work area.

Tools

- Make sure all tools are in good condition.
- Make sure all standard electrical tools are grounded.
- Check for frayed power cords before using power tools.

Fluids under pressure

- Use extreme caution when working on systems under pressure.
- Follow approved procedures only.

Fuel

- Do not over fill the fuel tank. Over fill creates a fire hazard.
- Do not smoke in the work area.
- Do not refuel the tank when the engine is running.

Removal of tools, parts, and equipment

- Reinstall all safety guards, shields, and covers after servicing the engine.
- Make sure all tools, parts, and service equipment are removed from the engine and vehicle after all work is done.

Table of Contents

Engine Identification.....7

- Engine Serial Number.....7
- Engine Emission Label.....7
- Engine Accessory Labels.....7
- Engine Description.....8
 - Standard Features.....9
 - Optional Features.....10
 - Chassis Mounted Features.....10
- Engine Component Locations.....11

Air Management System.....16

- Air Flow.....17
- Air Management Components.....17
 - Charge Air Cooler (CAC).....17
 - Exhaust Gas Recirculation (EGR) System.....18
 - Variable Geometry Turbocharger (VGT).....20
 - Aftertreatment (AFT) System.....22

Fuel Management System.....23

- ICP System.....24
 - High-Pressure Oil Flow.....24
 - ICP Closed Loop System.....25
 - ICP Control System.....26
 - Fuel Injector.....27

Fuel Supply System.....29

- Fuel Supply System Flow.....30

Engine Lubrication System.....33

- Oil Flow.....34

Engine Cooling System.....36

- Cooling System Flow.....37
- Cooling System Components.....37
 - Coolant Heater (optional).....37
 - Thermostat Operation.....38

Electronic Control System.....39

- Electronic Control System Components.....39
 - Operation and Function.....39
 - Reference Voltage (VREF).....40
 - Signal Conditioner.....40
 - Microprocessor.....40
 - Microprocessor Memory.....40
 - Actuator Control.....41
- Actuators.....41

EGR Valve.....	41
IAH Relays.....	41
Intake Throttle Actuator and Position Sensor.....	41
Engine and Vehicle Sensors.....	42
Thermistor Sensors.....	42
Variable Capacitance Sensors.....	44
Magnetic Pickup Sensors.....	45
Micro Strain Gauge (MSG) Sensors.....	46
Potentiometer.....	47
Switches.....	48
Intake Throttle Valve.....	49
Diamond Logic® Brake System.....	50
Brake Operation Modes.....	51
Exhaust Brake System.....	51
Engine Brake System.....	52

Engine Identification

Engine Serial Number



Figure 1 Engine serial number

The engine serial number is in two locations:

- Stamped on a crankcase pad on the right side of the crankcase below the cylinder head.
- On the engine emission label on the valve cover.

Engine Serial Number Examples

International® MaxxForce® DT: 466HM2U3000001

International® MaxxForce® 9 and 10:
570HM2U3000001

Engine Serial Number Codes

466 – Engine displacement

570 – Engine displacement

H – Diesel, turbocharged, Charge Air Cooler (CAC) and electronically controlled

M2 – Motor truck

U – United States

7 digit suffix – Engine serial number sequence beginning with 3000001

Engine Emission Label

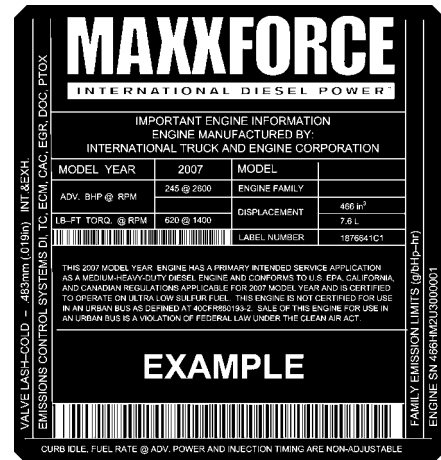

K35172

Figure 2 U.S. Environmental Protection Agency (EPA) exhaust emission label (example)

The U.S. Environmental Protection Agency (EPA) exhaust emission label is attached on top of the valve cover. The EPA label typically includes the following:

- Model year
- Engine family, model, and displacement
- Advertised brake horsepower and torque rating
- Emission family and control systems
- Valve lash specifications
- Engine serial number
- EPA, EURO, and reserved fields for specific applications

Engine Accessory Labels

The following engine accessories may have manufacturer's labels or identification plates:

- Air compressor
- Air conditioning compressor
- Alternator
- Cooling fan clutch
- Power steering pump
- Starter motor

Engine Description

International® MaxxForce® DT, 9, and 10 Diesel Engines

Engine configuration	4 stroke, inline six cylinder diesel
MaxxForce® DT displacement	7.6 L (466 in ³)
MaxxForce® 9 and 10 displacement	9.3 L (570 in ³)
Bore (sleeve diameter)	116.6 mm (4.59 in)
Stroke	
• MaxxForce® DT	119 mm (4.68 in)
• MaxxForce® 9 and 10	146 mm (5.75 in)
Compression ratio	
• MaxxForce® DT	16.9 : 1
• MaxxForce® 9 and 10	17.2 : 1
Aspiration	VGT turbocharged and Charge Air Cooled (CAC)
Rated power @ rpm ¹	
• MaxxForce® DT	245 bhp @ 2600 rpm
• MaxxForce® 9	310 bhp @ 2200 rpm
• MaxxForce® 10	310 bhp @ 2200 rpm
Peak torque @ rpm ¹	
• MaxxForce® DT	620 lbf-ft @ 1400 rpm
• MaxxForce® 9	950 lbf-ft @ 1200 rpm
• MaxxForce® 10	1050 lbf-ft @ 1200 rpm
Engine rotation (facing flywheel)	Counterclockwise
Combustion system	Direct injection turbocharged
Fuel system	Electro-hydraulic injection
Total engine weight (oil and accessories)	
• MaxxForce® DT	881 kg (1,943 lbs)
• MaxxForce® 9 and 10	905 kg (1,995 lbs)
Cooling system capacity (engine only)	12.8 L (13.5 qts US)
Lube system capacity (including filter)	28 L (30 qts US)
Lube system capacity (overhaul only, with filter)	33 L (35 qts US)
Firing order	1-5-3-6-2-4

¹ Example ratings shown. See Performance Specifications appendix in Diagnostic Manual for additional ratings.

Standard Features

MaxxForce® DT, 9, and 10 diesel engines are designed for increased durability, reliability, and ease of maintenance.

The cylinder head has four valves per cylinder with centrally located fuel injectors directing fuel over the pistons. This configuration provides improved performance and reduces emissions.

The camshaft is supported by four insert bushings pressed into the crankcase. The camshaft gear is driven from the front of the engine. A thrust flange is located between the camshaft and the drive gear. The overhead valve train includes mechanical roller lifters, push rods, rocker arms, and dual valves that open using a valve bridge.

MaxxForce® DT engines use one piece aluminum alloy pistons. MaxxForce® 9 and 10 engines use one piece steel pistons. All pistons use an offset piston axis and centered combustion bowls. Crown markings show correct piston orientation in the crankcase.

The one piece crankcase uses replaceable wet cylinder sleeves that are sealed by a single crevice seal. Some applications include a crankcase ladder which is designed to support heavier loads and reduce engine noise.

The crankshaft has seven main bearings with fore and aft thrust controlled at the rear bearing. One fractured cap connecting rod is attached at each crankshaft journal. A piston pin moves freely inside the connecting rod and piston. Piston pin retaining rings secure the piston pin in the piston. The rear oil seal carrier is part of the flywheel housing.

A gerotor lube oil pump is mounted on the front cover and is driven by the crankshaft. Pressurized oil is supplied to engine components and the high-pressure injection system. All MaxxForce® DT, 9, and 10 engines use an engine oil cooler and spin-on engine oil filter.

The water supply housing serves as the mounting bracket for the Freon® compressor. Mounting capabilities for a dual Freon® compressor are

available as an option. The pad mounting design of the alternator and Freon® compressor brackets provide easy removal and improved durability.

The low-pressure fuel supply pump draws fuel from the fuel tank through the fuel filter housing. The housing includes a strainer, filter, primer pump, drain valve, Water in Fuel (WIF) sensor, and Engine Fuel Pressure (EFP) sensor. If equipped, an optional fuel heater element is located in the fuel filter housing. Conditioned fuel is pumped through the intake manifold and cylinder head to the fuel injectors.

The WIF sensor detects water in the fuel system. When a programmed value of water is collected in the fuel filter housing, the instrument panel's amber FUEL FILTER lamp will illuminate. The collected water must be removed immediately. The water is drained by using the drain valve located on the fuel filter housing.

The fuel injection system is electro-hydraulic. The system includes an under-valve-cover high-pressure oil manifold, fuel injectors, and a high-pressure oil pump. The injectors are installed in the cylinder head, under the high-pressure oil manifold.

The Variable Geometry Turbocharger (VGT) has actuated vanes in the turbine housing. These vanes modify exhaust gas flow through the VGT. The ECM commands the VGT in response to boost and exhaust back pressure for various engine speeds and load conditions.

The Inlet Air Heater (IAH) system warms the incoming air supply prior to cranking to aid cold engine starting and reduce white smoke during warm-up. The IAH system will initially illuminate the WAIT TO START lamp located on the instrument panel. When the lamp turns off, the engine can be started.

The Exhaust Gas Recirculation (EGR) system circulates cooled exhaust into the intake air stream in the intake manifold. This cools the combustion process and reduces the formation of NO_x engine emissions.

A closed crankcase breather system uses an engine mounted oil separator to return oil to the crankcase and vent crankcase pressure into the intake system.

Optional Features

Optional features available include the following:

- Air compressor
- Power Takeoff (PTO)
- Engine or exhaust brake

An air compressor is available for applications that require air brakes or air suspension. A hydraulic power steering pump can be used with or without the air compressor.

The front cover has a mounting flange available for PTO accessories. The air compressor drive gear train is used with a spline adapter and provides power for front mounted PTO accessories.

The Diamond Logic® engine brake is available for all engine displacements. The engine brake is a compression release brake system that provides additional braking performance. The operator can control the engine brake for different operating conditions.

The Diamond Logic® exhaust brake system is also available for all engine displacements. The exhaust brake uses the turbocharger to restrict exhaust flow for additional braking. The operator can control the exhaust brake for different operating conditions.

Optional Cold Climate Features

Optional cold climate features available include the following:

- Oil pan heater
- Coolant heater
- Fuel heater

All three heaters use an electric element to warm engine fluids in cold weather conditions.

The oil pan heater warms engine oil to ensure optimum oil flow.

The coolant heater warms engine coolant surrounding the cylinders. Warmed engine coolant aids in performance and fuel economy during start-up.

The fuel heater is installed in the fuel filter header assembly and warms the supply fuel. Warmed supply fuel prevents waxing, and improves performance and fuel economy during cold weather start-up.

Chassis Mounted Features

A Charge Air Cooler (CAC) is an air-to-air heat exchanger which increases the density of the air charge.

The Aftertreatment System, part of the larger Exhaust System, processes engine exhaust to meet tailpipe emission requirements.

- The Diesel Oxidation Catalyst (DOC) burns oxygen and hydrocarbons in the exhaust stream.
- The Diesel Particulate Filter (DPF) captures and burns particulates in the exhaust stream.

Engine Component Locations

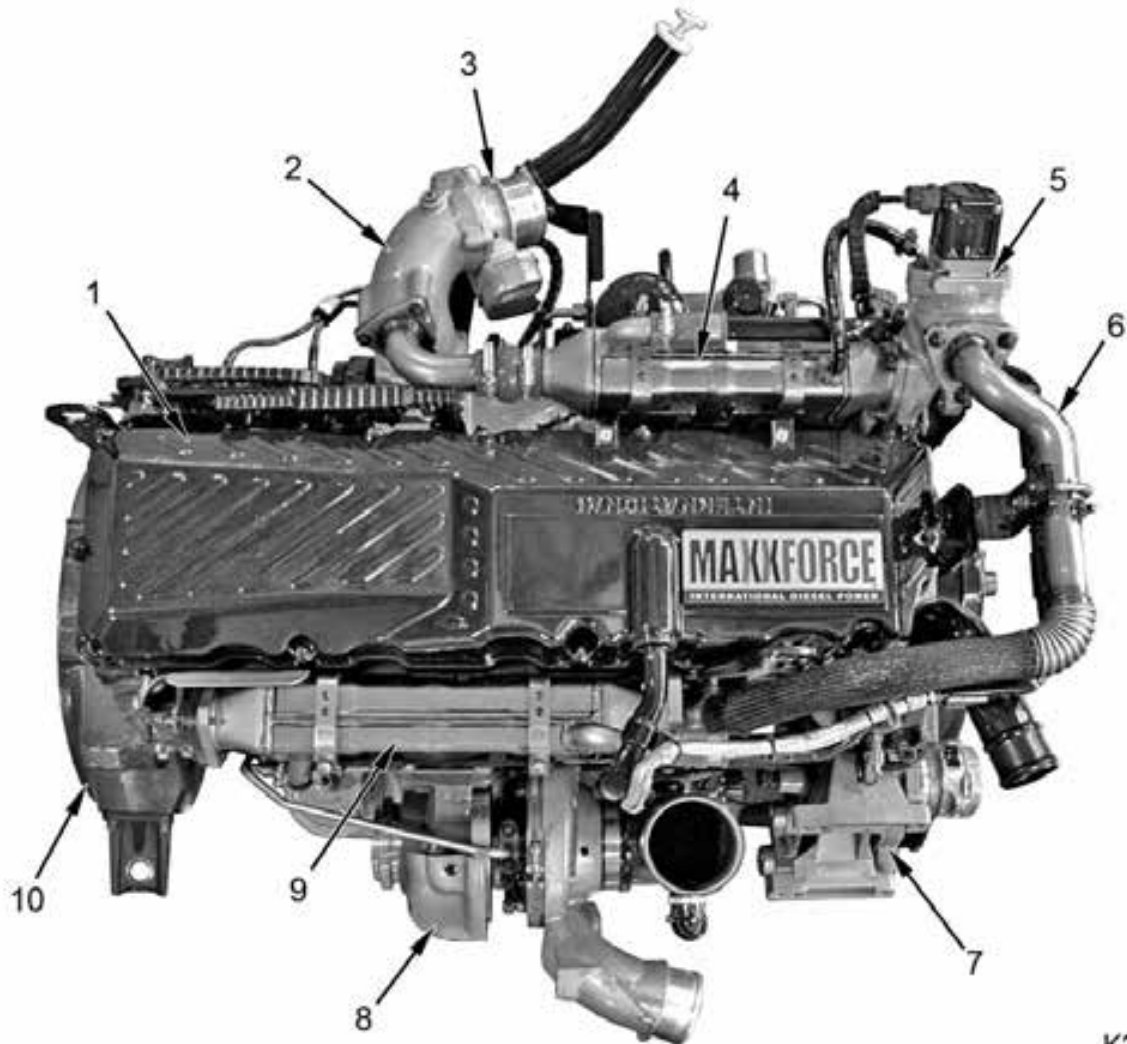

K35215

Figure 3 Component location – top

- | | | |
|---------------------------------|--|----------------------|
| 1. Valve cover | 6. EGR tube assembly | 10. Flywheel housing |
| 2. EGR and inlet air mixer duct | 7. Alternator bracket | |
| 3. Intake throttle assembly | 8. Variable Geometry Turbocharger (VGT) assembly | |
| 4. Intake side EGR cooler | 9. Exhaust side EGR cooler | |
| 5. EGR valve manifold assembly | | |

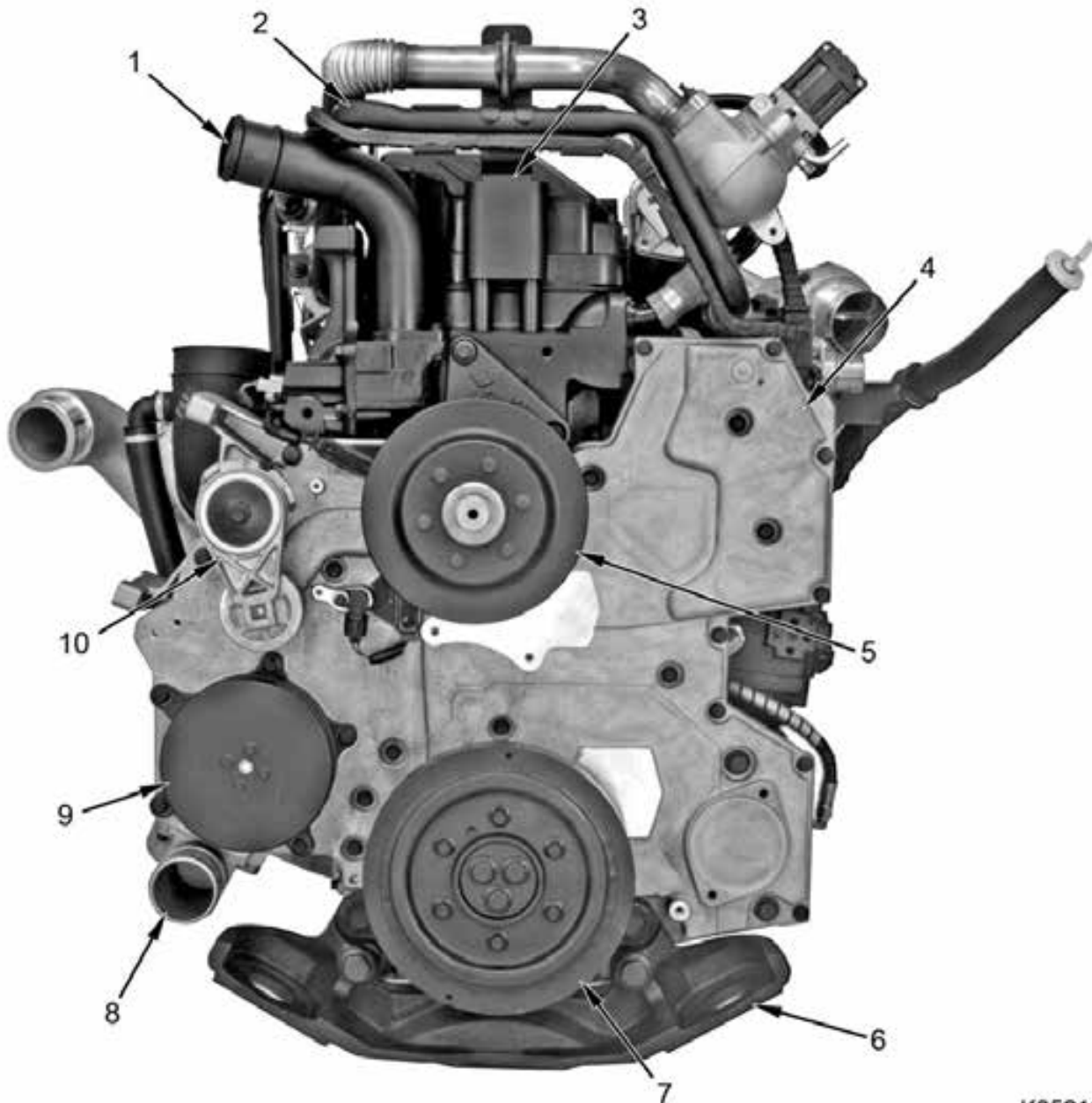

K35216

Figure 4 Component location – front

- | | | |
|--|----------------------------------|------------------------------|
| 1. Water outlet tube assembly | 4. Front cover | 8. Water inlet elbow |
| 2. Coolant crossover tube assembly (EGR) | 5. Fan drive pulley | 9. Water pump pulley |
| 3. Tube support | 6. Front engine mounting bracket | 10. Automatic belt tensioner |
| | 7. Vibration damper assembly | |

EGES-335-2

Read all safety instructions in the "Safety Information" section of this Manual before doing any procedures.

Follow all warnings, cautions, and notes.

©April 2011 Navistar, Inc. All rights reserved

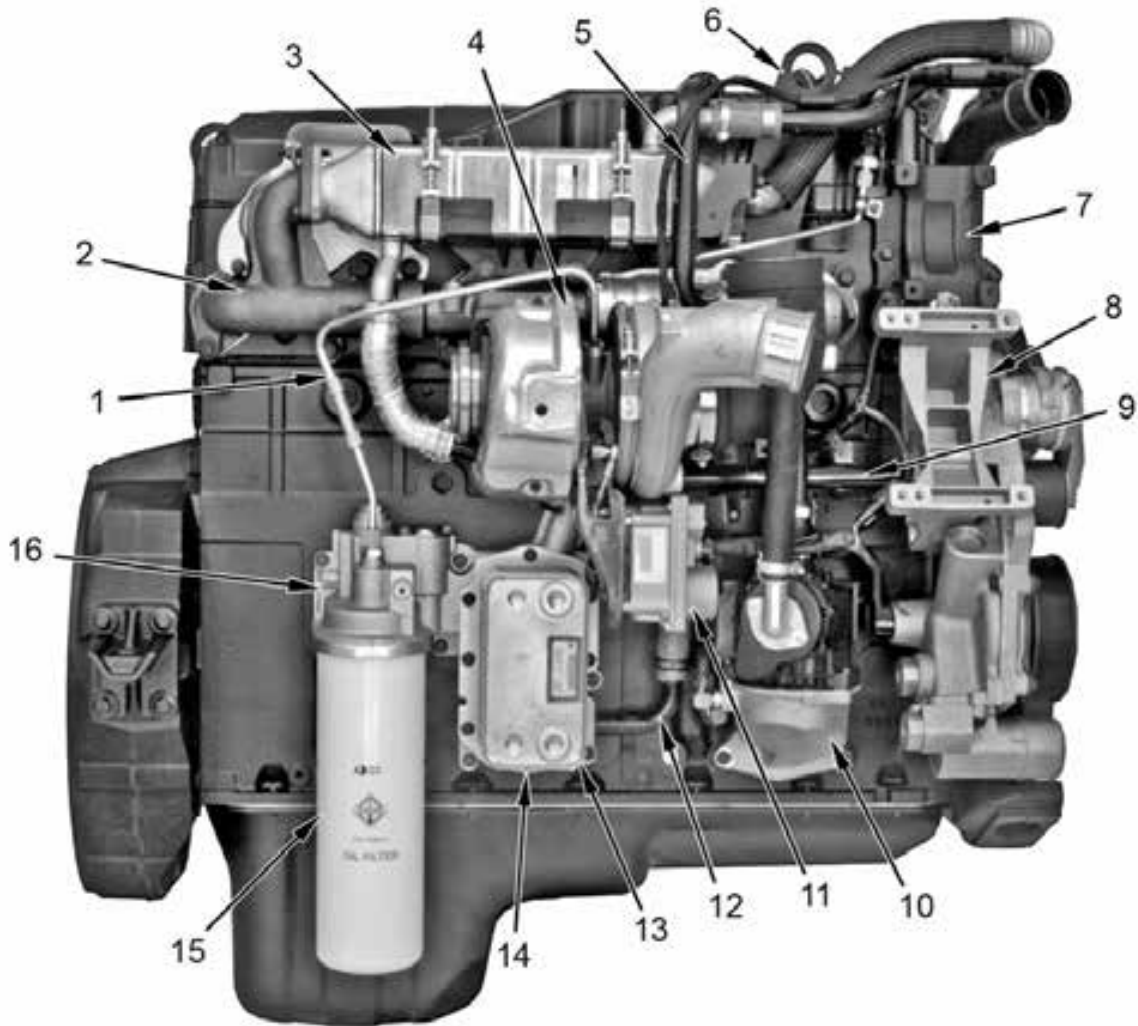

K35218

Figure 5 Component location – right

- | | | |
|--|---|---------------------------------------|
| 1. Turbocharger oil supply tube assembly | 6. Lifting eye | 11. VGT actuator |
| 2. Exhaust manifold | 7. Water supply housing (Freon® compressor mount) | 12. Coolant tube (oil system module) |
| 3. Exhaust side EGR cooler | 8. Alternator bracket | 13. Cooler heat exchanger |
| 4. Variable Geometry Turbocharger (VGT) assembly | 9. EGR coolant supply tube | 14. M18 plug assembly (coolant drain) |
| 5. Breather inlet tube assembly | 10. Crankcase breather assembly with turbine | 15. Oil filter |
| | | 16. Oil system module assembly |

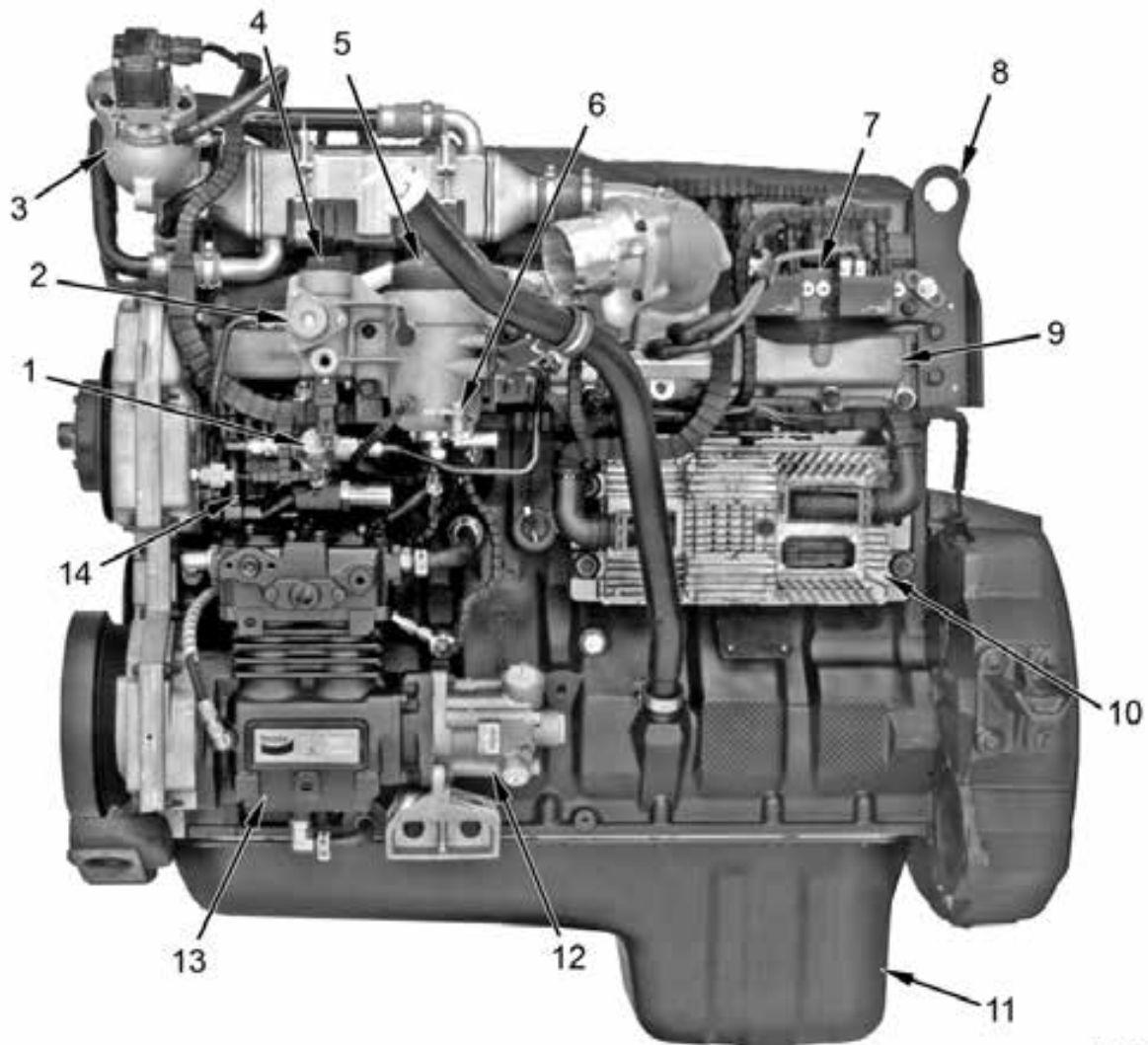

K35217

Figure 6 Component location – left

- | | | |
|--------------------------------|---|----------------------------------|
| 1. Low-pressure fuel pump | 6. Water drain valve | 10. ECM |
| 2. Priming pump (fuel) | 7. Intake Air Heater (IAH) relay assembly | 11. Oil pan |
| 3. EGR valve manifold assembly | 8. Lifting eye | 12. Power steering pump assembly |
| 4. Fuel strainer cap | 9. Intake manifold | 13. Air compressor assembly |
| 5. Fuel filter cap | | 14. High-pressure oil pump |

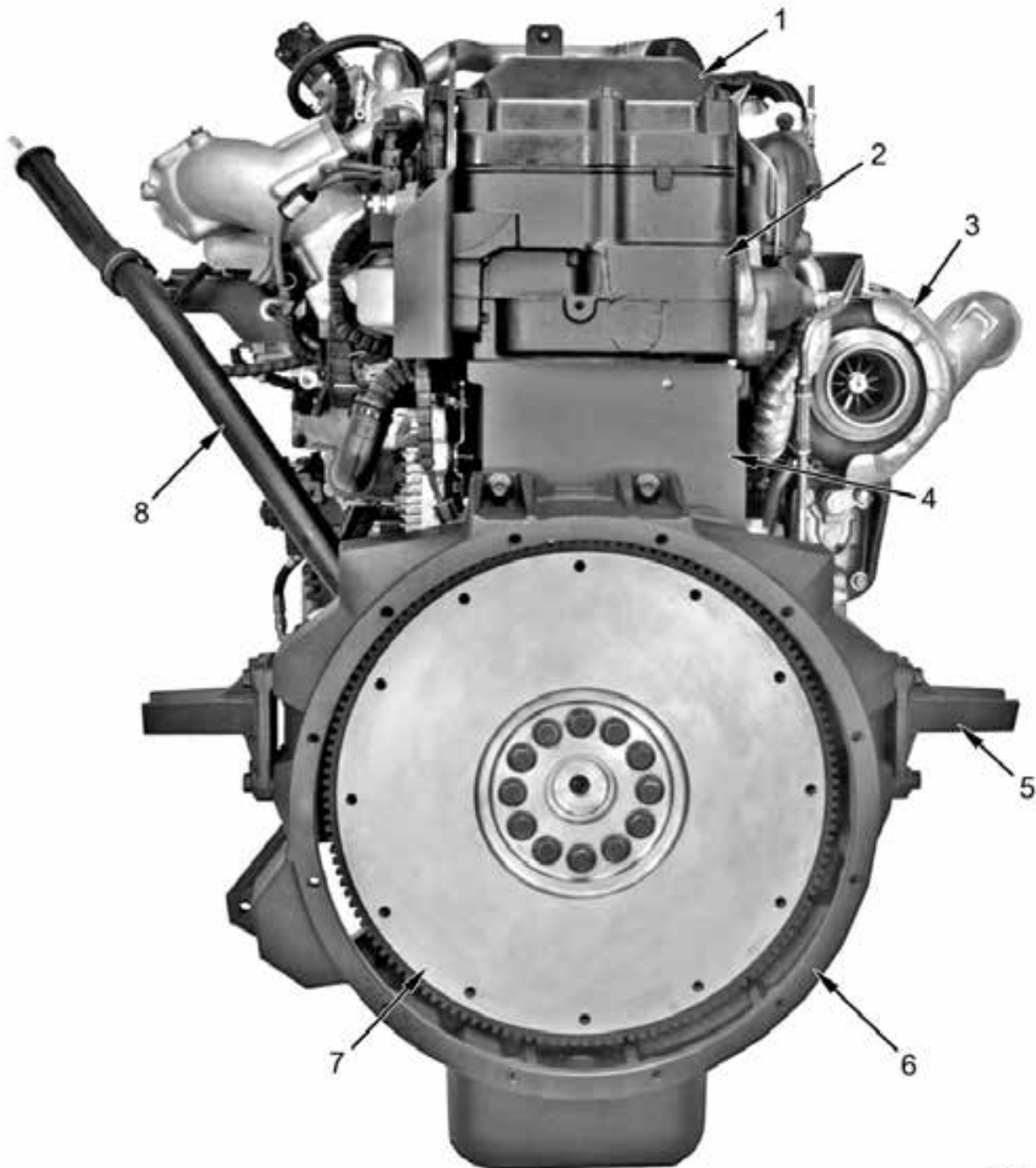

K35219

Figure 7 Component location – rear

- | | | |
|------------------|---------------------------------|---------------------|
| 1. Valve cover | 4. Crankcase | 6. Flywheel housing |
| 2. Cylinder head | 5. Rear engine mounting bracket | 7. Flywheel |
| 3. VGT assembly | (2) | 8. Oil filler tube |

EGES-335-2

Read all safety instructions in the "Safety Information" section of this Manual before doing any procedures.

Follow all warnings, cautions, and notes.

©April 2011 Navistar, Inc. All rights reserved

Air Management System

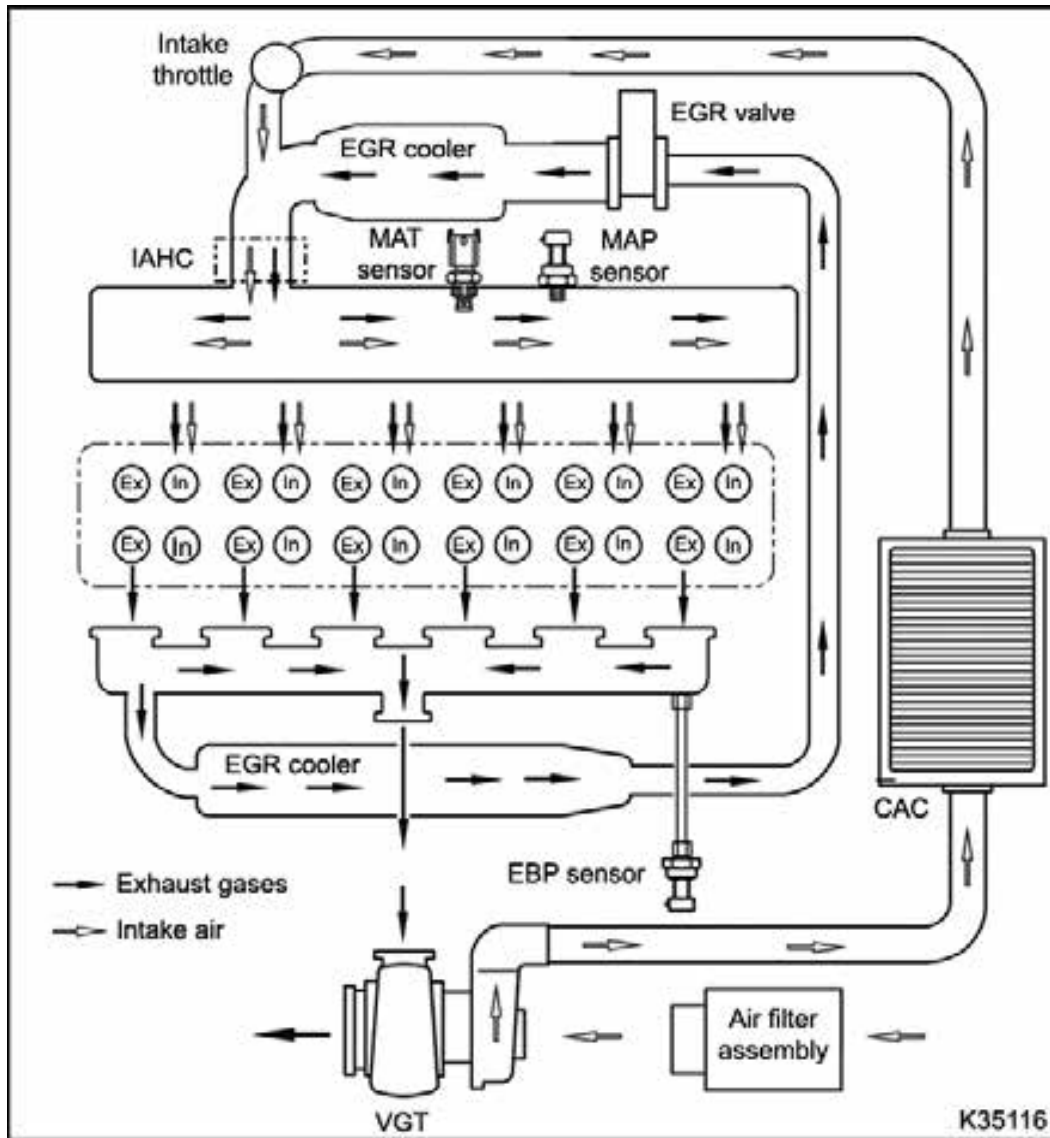

Figure 8 Air management system

The Air Management System includes the following:

- Air filter assembly
- Variable Geometry Turbocharger (VGT)
- Charge Air Cooler (CAC)
- Intake throttle valve
- Exhaust Gas Recirculation (EGR)
- Intake manifold and EGR mixer
- Inlet Air Heater Control (IAHC)
- Exhaust and intake valves
- Exhaust system
- Diamond Logic® exhaust and engine brake
- Diesel Particulate Filter (DPF – Aftertreatment System)

Air Flow

Air flows through the air filter assembly and enters the VGT. The VGT compressor increases the pressure, temperature, and density of the intake air before it enters the CAC. Cooled compressed air flows from the CAC into the inlet throttle valve and EGR mixer duct.

If the EGR control valve is open, exhaust gas will pass through the EGR system and mix with the filtered intake air. This mixture flows through the inlet air heater and into the intake manifold.

If the EGR control valve is closed, only filtered intake air will flow through the inlet air heater and into the intake manifold.

After combustion gases exit through the exhaust valves and ports, the gas is forced through the exhaust manifold to the EGR system and VGT.

Some gas flows through the EGR system, which is controlled by the EGR valve. The remaining gas flows to the VGT turbine.

The turbo vanes control flow and pressure of exhaust gas. This controls the speed of the compressor wheel, which is connected to the turbine wheel by a shaft. The VGT compressor wheel compresses the filtered air.

Exhaust gases exit the turbocharger, flow into the exhaust piping to the aftertreatment system, and are released from the exhaust tail pipe.

Air Management Components

Charge Air Cooler (CAC)

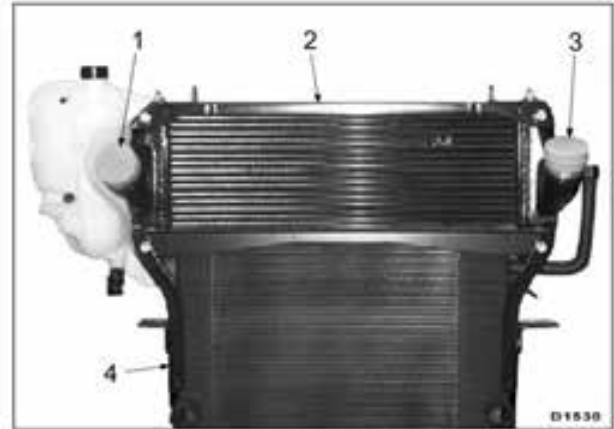

Figure 9 CAC

1. Air outlet
2. CAC
3. Air inlet
4. Radiator

The chassis mounted CAC is mounted on top of the radiator. Air from the turbocharger passes through a network of heat exchanger tubes before entering the engine intake system. Outside air flowing over the heat exchanger tube fins cools the charge air. Cooling the charge air increases the density and improves the air to fuel ratio during combustion.

Exhaust Gas Recirculation (EGR) System

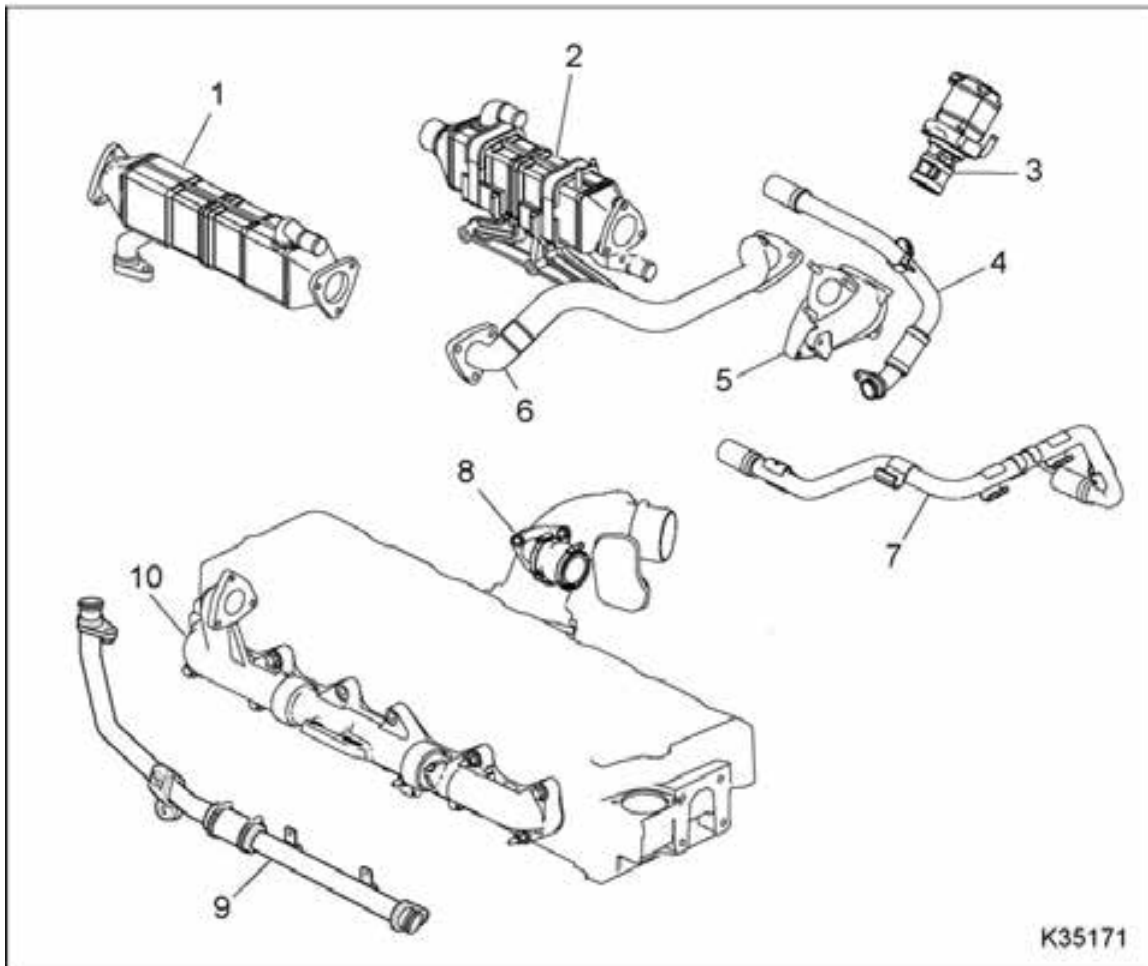

Figure 10 EGR system

- | | | |
|-------------------------------------|------------------------------------|----------------------------|
| 1. Exhaust side EGR cooler | 5. EGR valve manifold | 9. EGR coolant supply tube |
| 2. Intake side EGR cooler | 6. EGR tube assembly | 10. Exhaust manifold |
| 3. EGR valve | 7. Coolant crossover tube assembly | |
| 4. EGR coolant return tube assembly | 8. EGR metering tube | |

The EGR system includes the following:

- Exhaust manifold
- EGR exhaust side cooler
- Exhaust gas crossover tube
- Electrical control system
- EGR control valve
- EGR intake side cooler

- EGR mixer duct
- Intake manifold

The EGR system reduces Nitrogen Oxide (NO_x) engine emissions. NO_x forms during a reaction between nitrogen and oxygen at high temperatures during combustion. Combustion starts when fuel is injected into the compressed combustion chamber.