

Courtesy of NISSAN MOTOR CO., U.S.A.

Removal & Installation (Altima, Frontier & 240SX)

1. Release fuel pressure. See **FUEL PRESSURE RELEASE**. Drain coolant. Disconnect all necessary coolant hoses, electrical connectors, vacuum hoses, fuel lines and control cables.
2. Remove generator and mounting bracket. Remove intake air duct hose. Remove upper radiator hose. Remove harness connectors from radiator cooling fans. Remove 4 bolts and remove cooling fans and housing. Remove front Exhaust Gas Recycle (EGR) hose from intake manifold. Remove 2 intake manifold plenum supports between intake manifold and engine block. See **Fig. 7**.
3. Remove intake manifold bolts and remove intake manifold. To install, reverse removal procedure. Tighten intake manifold bolts to specification in sequence. See **Fig. 8** and **Fig. 9**. See **TORQUE SPECIFICATIONS**.

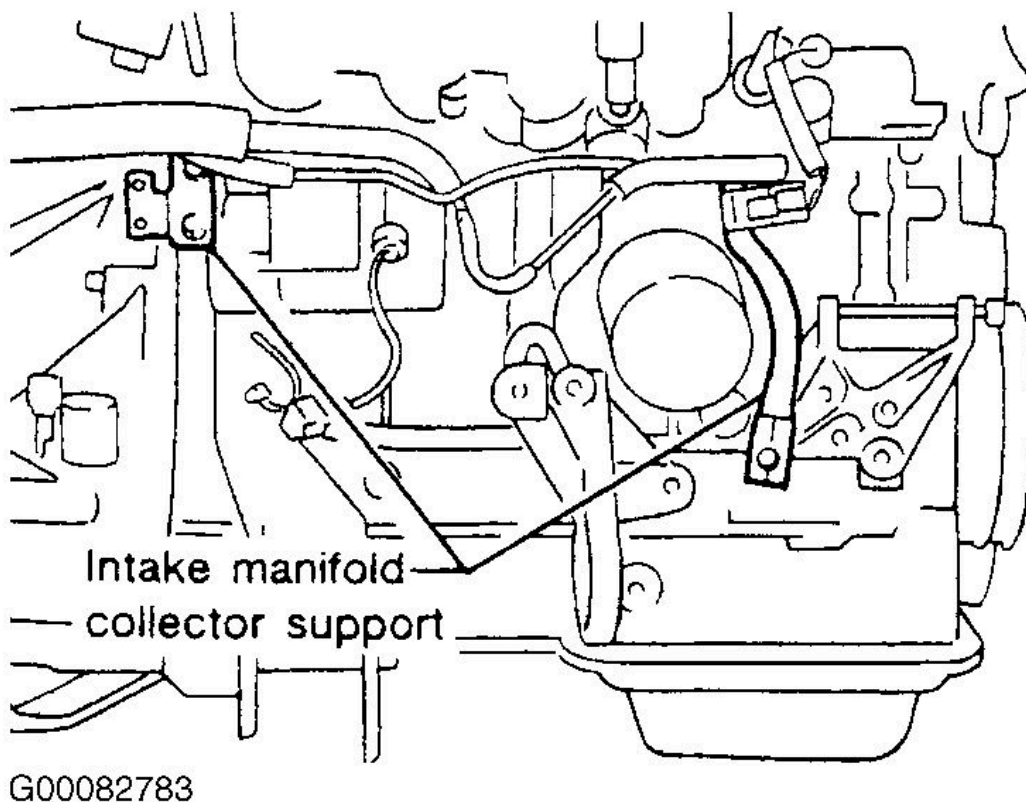
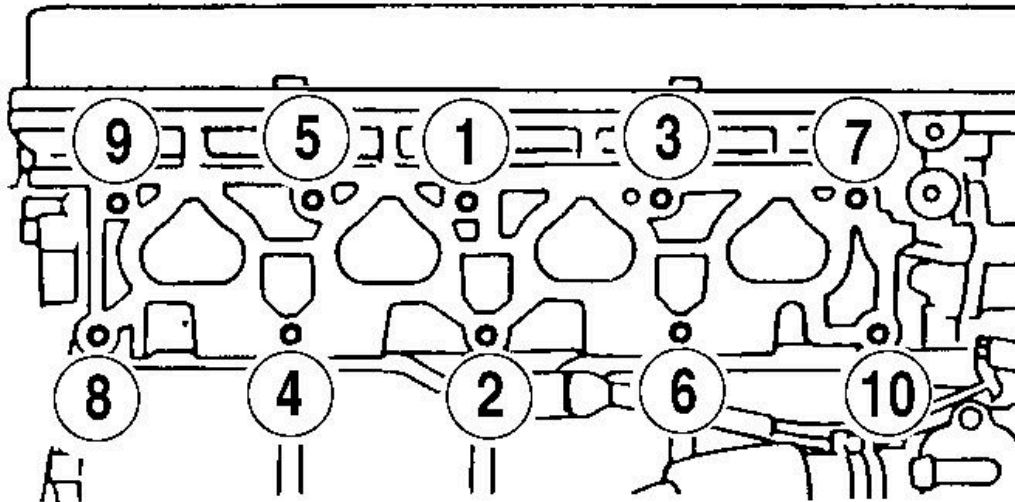

Fig. 7: Identifying Intake Manifold Plenum Supports
Courtesy of NISSAN MOTOR CO., U.S.A.

1998 Nissan 240SX SE

2.4L 4-CYL VINS [A,B,D,S] 1997-98 ENGINES Nissan 2.4L 4-Cylinder

FRONT OF ENGINE ➔



G92G01564

Fig. 8: Intake Manifold Tightening Sequence (Altima, Frontier & 240SX)
Courtesy of NISSAN MOTOR CO., U.S.A.

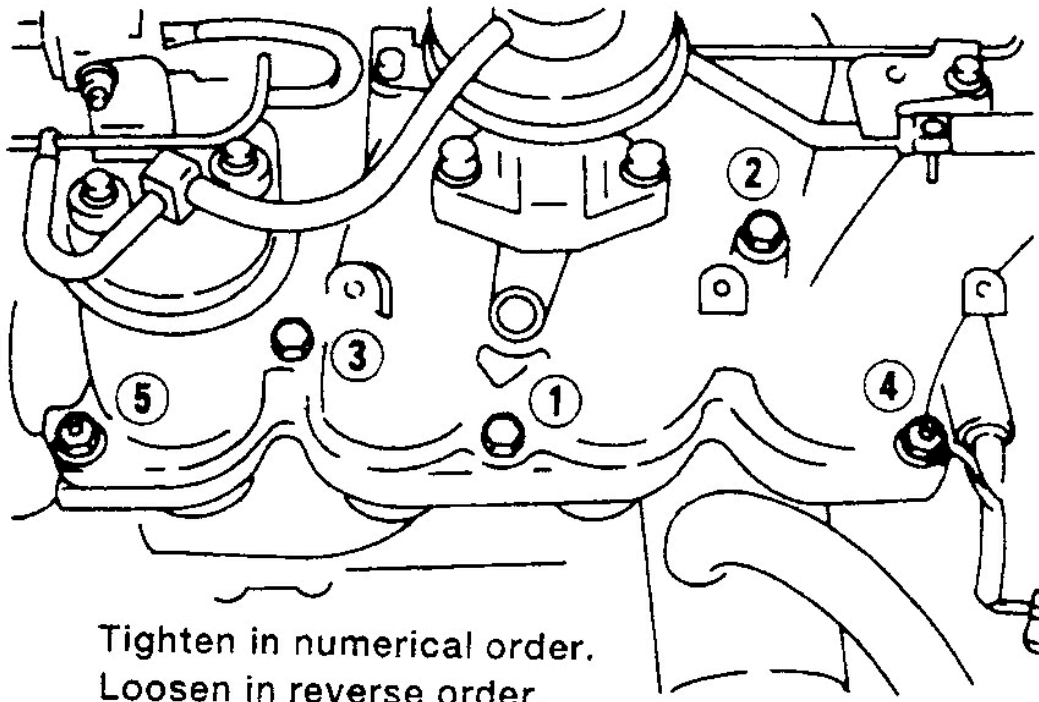

Tighten in numerical order.
Loosen in reverse order.

G00082784

Fig. 9: Intake Manifold Plenum Tightening Sequence
Courtesy of NISSAN MOTOR CO., U.S.A.

EXHAUST MANIFOLD

Removal & Installation

Disconnect exhaust pipe from manifold. Remove exhaust manifold heat shield. Remove exhaust manifold. To install, reverse removal procedure. Tighten nuts and bolts to specification in sequence. See **Fig. 10** or **Fig. 11**. See **TORQUE SPECIFICATIONS**.

1998 Nissan 240SX SE

2.4L 4-CYL VINS [A,B,D,S] 1997-98 ENGINES Nissan 2.4L 4-Cylinder

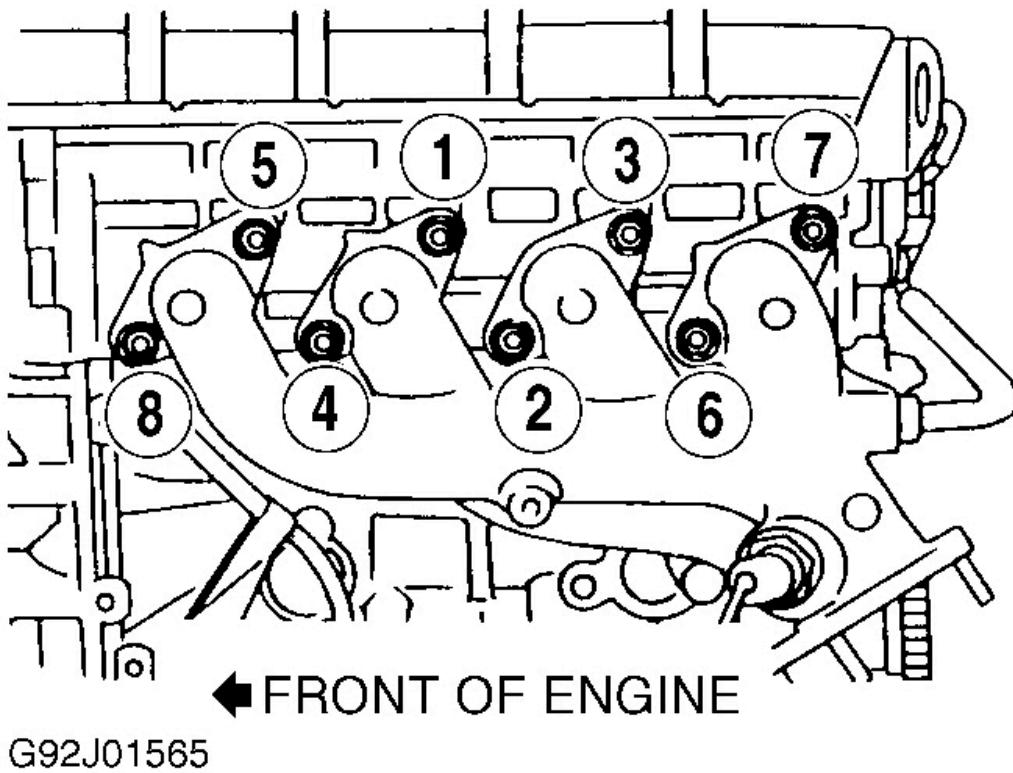

Fig. 10: Exhaust Manifold Tightening Sequence (Altima, Frontier & 240SX)
Courtesy of NISSAN MOTOR CO., U.S.A.