

A
B
C

SECTION RAX

REAR AXLE

RAX

CONTENTS

PRECAUTION	2	PERIODIC MAINTENANCE	6	F
PRECAUTIONS	2	REAR WHEEL HUB	6	
Precaution for Technicians Using Medical Electric.....	2	Inspection	6	G
Point to Be Checked Before Starting Maintenance Work	2	REMOVAL AND INSTALLATION	7	
Precaution for Supplemental Restraint System (SRS) "AIR BAG" and "SEAT BELT PRE-TENSIONER"	2	REAR WHEEL HUB	7	H
PREPARATION	4	Exploded View	7	
PREPARATION	4	Removal and Installation	7	
Commercial Service Tools	4	Inspection	8	I
SYMPTOM DIAGNOSIS	5	SERVICE DATA AND SPECIFICATIONS (SDS)	9	J
NOISE, VIBRATION AND HARSHNESS (NVH) TROUBLESHOOTING	5	SERVICE DATA AND SPECIFICATIONS (SDS)	9	
NVH Troubleshooting Chart	5	Wheel Bearing	9	K

PRECAUTIONS

< PRECAUTION >

PRECAUTION

PRECAUTIONS

Precaution for Technicians Using Medical Electric

INFOID:000000010120223

OPERATION PROHIBITION

WARNING:

- Parts with strong magnet is used in this vehicle.
- Technicians using a medical electric device such as pacemaker must never perform operation on the vehicle, as magnetic field can affect the device function by approaching to such parts.

NORMAL CHARGE PRECAUTION

WARNING:

- If a technician uses a medical electric device such as an implantable cardiac pacemaker or an implantable cardioverter defibrillator, the possible effects on the devices must be checked with the device manufacturer before starting the charge operation.
- As radiated electromagnetic wave generated by PDM (Power Delivery Module) at normal charge operation may affect medical electric devices, a technician using a medical electric device such as implantable cardiac pacemaker or an implantable cardioverter defibrillator must not approach motor room [PDM (Power Delivery Module)] at the hood-opened condition during normal charge operation.

PRECAUTION AT TELEMATICS SYSTEM OPERATION

WARNING:

- If a technician uses implantable cardiac pacemaker or implantable cardioverter defibrillator (ICD), avoid the device implanted part from approaching within approximately 220 mm (8.66 in) from interior/exterior antenna.
- The electromagnetic wave of TCU might affect the function of the implantable cardiac pacemaker or the implantable cardioverter defibrillator (ICD), when using the service, etc.
- If a technician uses other medical electric devices than implantable cardiac pacemaker or implantable cardioverter defibrillator (ICD), the electromagnetic wave of TCU might affect the function of the device. The possible effects on the devices must be checked with the device manufacturer before TCU use.

PRECAUTION AT INTELLIGENT KEY SYSTEM OPERATION

WARNING:

- If a technician uses implantable cardiac pacemaker or implantable cardioverter defibrillator (ICD), avoid the device implanted part from approaching within approximately 220 mm (8.66 in) from interior/exterior antenna.
- The electromagnetic wave of Intelligent Key might affect the function of the implantable cardiac pacemaker or the implantable cardioverter defibrillator (ICD), at door operation, at each request switch operation, or at engine starting.
- If a technician uses other medical electric devices than implantable cardiac pacemaker or implantable cardioverter defibrillator (ICD), the electromagnetic wave of Intelligent Key might affect the function of the device. The possible effects on the devices must be checked with the device manufacturer before Intelligent Key use.

Point to Be Checked Before Starting Maintenance Work

INFOID:000000010120224

The high voltage system may starts automatically. It is required to check that the timer air conditioner and timer charge (during EVSE connection) are not set before starting maintenance work.

NOTE:

If the timer air conditioner or timer charge (during EVSE connection) is set, the high voltage system starts automatically even when the power switch is in OFF state.

Precaution for Supplemental Restraint System (SRS) "AIR BAG" and "SEAT BELT PRE-TENSIONER"

INFOID:000000010120225

The Supplemental Restraint System such as "AIR BAG" and "SEAT BELT PRE-TENSIONER", used along with a front seat belt, helps to reduce the risk or severity of injury to the driver and front passenger for certain types of collision. This system includes seat belt switch inputs and dual stage front air bag modules. The SRS

PRECAUTIONS

< PRECAUTION >

system uses the seat belt switches to determine the front air bag deployment, and may only deploy one front air bag, depending on the severity of a collision and whether the front occupants are belted or unbelted. Information necessary to service the system safely is included in the SR and SB section of this Service Manual.

WARNING:

- To avoid rendering the SRS inoperative, which could increase the risk of personal injury or death in the event of a collision which would result in air bag inflation, all maintenance must be performed by an authorized NISSAN/INFINITI dealer.
- Improper maintenance, including incorrect removal and installation of the SRS, can lead to personal injury caused by unintentional activation of the system. For removal of Spiral Cable and Air Bag Module, see the SR section.
- Do not use electrical test equipment on any circuit related to the SRS unless instructed to in this Service Manual. SRS wiring harnesses can be identified by yellow and/or orange harnesses or harness connectors.

PRECAUTIONS WHEN USING POWER TOOLS (AIR OR ELECTRIC) AND HAMMERS

WARNING:

- When working near the Airbag Diagnosis Sensor Unit or other Airbag System sensors with the Ignition ON or engine running, DO NOT use air or electric power tools or strike near the sensor(s) with a hammer. Heavy vibration could activate the sensor(s) and deploy the air bag(s), possibly causing serious injury.
- When using air or electric power tools or hammers, always switch the Ignition OFF, disconnect the battery and wait at least three minutes before performing any service.

A

B

C

RAX

E

F

G

H

I

J

K

L

M

N

O

P

PREPARATION



< PREPARATION >

PREPARATION

PREPARATION

Commercial Service Tools

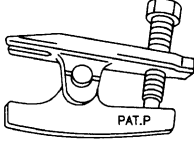
INFOID:000000010120226

Tool name	Description
Ball joint remover  NT146	Removing hub bolt
Power tool  PIIB1407E	Loosening nuts, screws and bolts.

NOISE, VIBRATION AND HARSHNESS (NVH) TROUBLESHOOTING

< SYMPTOM DIAGNOSIS >

SYMPTOM DIAGNOSIS

NOISE, VIBRATION AND HARSHNESS (NVH) TROUBLESHOOTING

NVH Troubleshooting Chart

INFOID:000000010120227

Use chart below to find the cause of the symptom. If necessary, repair or replace these parts.

Reference			RAX-7	—	RAX-6	RSU-5	WT-42	WT-42	BR-479
Possible cause and SUSPECTED PARTS			Improper installation, looseness	Parts interference	Wheel bearing damage	REAR SUSPENSION	TIRE	ROAD WHEEL	BRAKE
Symptom	REAR AXLE	Noise	x	x	x	x	x	x	x
		Shake	x	x	x	x	x	x	x
		Vibration	x	x	x	x	x		
		Shimmy	x	x		x	x	x	x
		Shudder	x			x	x	x	x
		Poor quality ride or handling	x	x		x	x	x	

x: Applicable

A
B
C
RAX
E
F
G
H
I
J
K
L
M
N
O
P

REAR WHEEL HUB

< PERIODIC MAINTENANCE >

PERIODIC MAINTENANCE

REAR WHEEL HUB

Inspection

INFOID:000000010120228

COMPONENT PART

Check the mounting conditions (looseness, back lash) of each component and component conditions (wear, damage) are normal.

WHEEL HUB ASSEMBLY (BEARING-INTEGRATED TYPE)

Check the following items, and replace the part if necessary.

- Move wheel hub assembly in the axial direction by hand. Check there is no looseness of wheel bearing.

Axial end play : Refer to [RAX-9, "Wheel Bearing"](#).

- Rotate wheel hub assembly and check there is no unusual noise or other irregular conditions. If there is any of irregular conditions, replace wheel hub assembly.

REAR WHEEL HUB

< REMOVAL AND INSTALLATION >

REMOVAL AND INSTALLATION

REAR WHEEL HUB

Exploded View

INFOID:0000000010120229

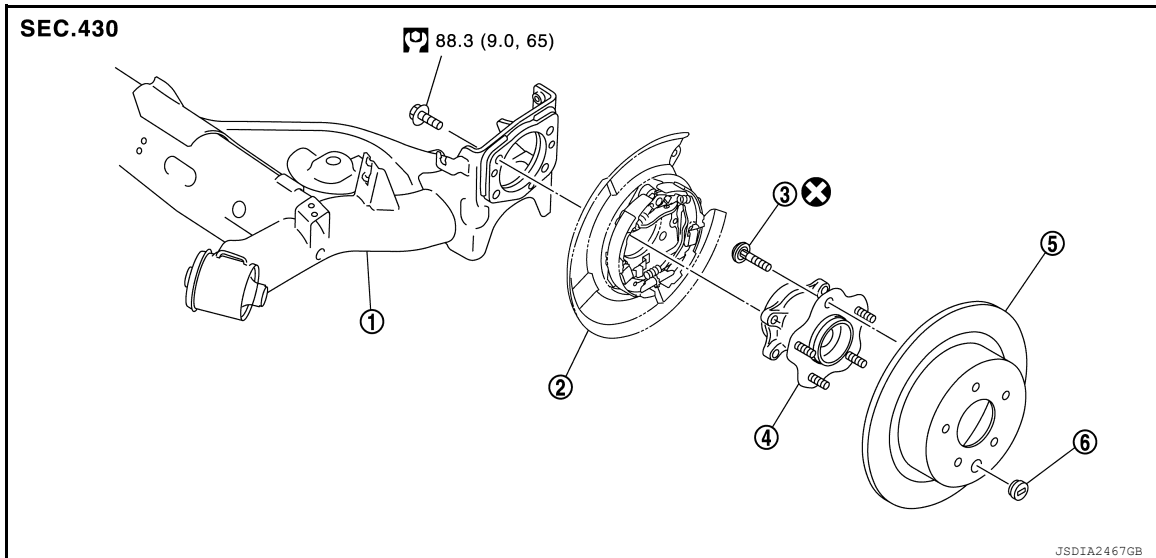

- | | | |
|---|--------------------------------|-------------|
| 1. Rear suspension beam | 2. Parking brake shoe assembly | 3. Hub bolt |
| 4. Wheel hub assembly (Bearing-integrated type) | 5. Disc rotor | 6. Plug |

: N·m (kg-m, ft-lb)

: Always replace after every disassembly.

Removal and Installation

INFOID:0000000010120230

REMOVAL

1. Remove wheel and tire using power tool. Refer to [WT-45, "Exploded View"](#).
2. Remove wheel sensor. Refer to [BRC-159, "REAR WHEEL SENSOR : Removal and Installation"](#).
3. Remove caliper assembly. Hang caliper assembly in a place where it will not interfere with work. Refer to [BR-526, "BRAKE CALIPER ASSEMBLY : Removal and Installation"](#).

CAUTION:

Do not depress brake pedal while brake caliper is removed.

4. Remove disc rotor. If disc rotor cannot be removed, remove as follows.

CAUTION:

- Parking brake completely in the released position.
- Put matching marks (A) on the wheel hub assembly and the disc rotor before removing the disc rotor.
- Do not drop disc rotor.

- a. Fix the disc rotor with wheel nuts and remove the adjusting hole plug.

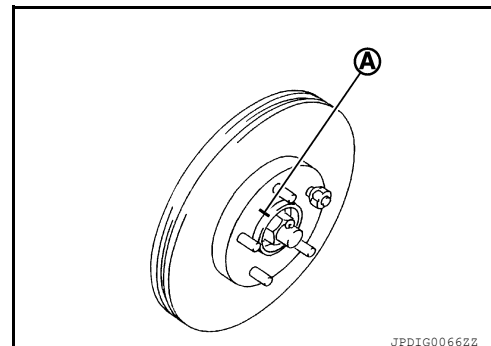

REAR WHEEL HUB

< REMOVAL AND INSTALLATION >

- b. Using suitable tool, rotate adjuster (1) in the direction (A) to retract and loosen brake shoe.
- c. Remove disc rotor.
5. Remove wheel hub assembly with power tool.

CAUTION:

Do not remove parking brake shoe assembly. Protect it from falling.

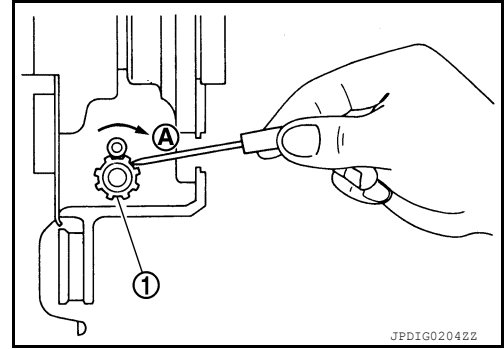

6. Remove hub bolts (1) from wheel hub assembly, using suitable tool (A).

CAUTION:

- Remove hub bolt only when necessary.
- Do not hammer the hub bolt to avoid impact to the wheel bearing.
- Pull out the hub bolt in a direction perpendicular to the wheel hub assembly.

7. Perform inspection after removal. Refer to [RAX-8. "Inspection"](#).

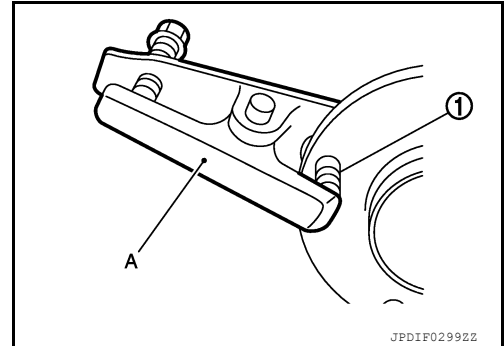

INSTALLATION

Note the following, and install in the reverse order of removal.

- Place a washer (A) as shown to install the hub bolts (1) by using the tightening force of the nut (B).

CAUTION:

- Check that there is no clearance between wheel hub assembly and hub bolt.
 - Do not reuse hub bolt.
- Fit the pin of rear brake assembly to hole of rear suspension beam when install rear brake assembly.
 - Align the matching marks that have been made during removal when reusing the disc rotor.
 - Perform inspection after installation. Refer to [RAX-8. "Inspection"](#).

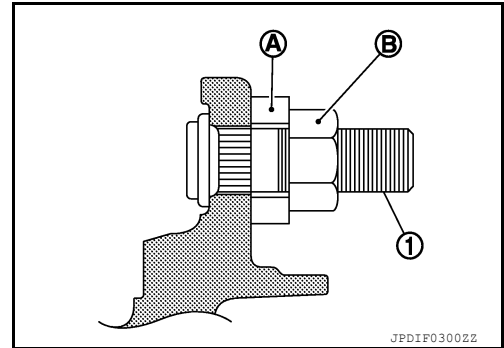

Inspection

INFOID:000000010120231

INSPECTION AFTER REMOVAL

Check the wheel hub assembly for wear, cracks, and damage. Replace if necessary.

INSPECTION AFTER INSTALLATION

1. Check wheel sensor harness for proper connection. [BRC-159. "REAR WHEEL SENSOR : Exploded View"](#).
2. Adjust parking brake operation (stroke). Refer to [PB-6. "Adjustment"](#).
3. Check wheel alignment. Refer to [RSU-7. "Inspection"](#).
4. Adjust neutral position of steering angle sensor. Refer to [BRC-70. "Work Procedure"](#).

SERVICE DATA AND SPECIFICATIONS (SDS)

< SERVICE DATA AND SPECIFICATIONS (SDS)

SERVICE DATA AND SPECIFICATIONS (SDS)

SERVICE DATA AND SPECIFICATIONS (SDS)

Wheel Bearing

INFOID:0000000010120232

Item	Standard
Axial end play	0.05 mm (0.002 in) or less

A

B

C

RAX

E

F

G

H

I

J

K

L

M

N

O

P