

A
B
C

SECTION **PB**

PARKING BRAKE SYSTEM

CONTENTS

PRECAUTION	2	PARKING BRAKE CONTROL	7	PB
PRECAUTIONS	2	Exploded View	7	
Precaution for Supplemental Restraint System (SRS) "AIR BAG" and "SEAT BELT PRE-TENSIONER"	2	Removal and Installation	7	
PREPARATION	3	PARKING BRAKE FRONT CABLE	9	G
PREPARATION	3	Removal and Installation	9	
Commercial Service Tool	3	PARKING BRAKE REAR CABLE	10	H
BASIC INSPECTION	4	Removal and Installation	10	
PARKING BRAKE SHOE	4	PARKING BRAKE SWITCH	11	I
Inspection	4	Removal and Installation	11	
PERIODIC MAINTENANCE	5	PARKING BRAKE SHOE	12	J
PARKING BRAKE SYSTEM	5	Exploded View	12	
Inspection	5	Removal and Installation	12	
Adjustment	5	Break-In Procedure	13	
REMOVAL AND INSTALLATION	7	SERVICE DATA AND SPECIFICATIONS (SDS)	14	K
		SERVICE DATA AND SPECIFICATIONS (SDS)	14	L
		Parking Drum Brake	14	M
		Parking Brake Control	14	

PRECAUTIONS

< PRECAUTION >

PRECAUTION

PRECAUTIONS

Precaution for Supplemental Restraint System (SRS) "AIR BAG" and "SEAT BELT PRE-TENSIONER"

INFOID:000000012213874

The Supplemental Restraint System such as "AIR BAG" and "SEAT BELT PRE-TENSIONER", used along with a front seat belt, helps to reduce the risk or severity of injury to the driver and front passenger for certain types of collision. Information necessary to service the system safely is included in the SR and SB section of this Service Manual.

WARNING:

- To avoid rendering the SRS inoperative, which could increase the risk of personal injury or death in the event of a collision which would result in air bag inflation, all maintenance must be performed by an authorized NISSAN/INFINITI dealer.
- Improper maintenance, including incorrect removal and installation of the SRS, can lead to personal injury caused by unintentional activation of the system. For removal of Spiral Cable and Air Bag Module, see the SR section.
- Do not use electrical test equipment on any circuit related to the SRS unless instructed to in this Service Manual. SRS wiring harnesses can be identified by yellow and/or orange harnesses or harness connectors.

PRECAUTIONS WHEN USING POWER TOOLS (AIR OR ELECTRIC) AND HAMMERS

WARNING:

- When working near the Airbag Diagnosis Sensor Unit or other Airbag System sensors with the Ignition ON or engine running, DO NOT use air or electric power tools or strike near the sensor(s) with a hammer. Heavy vibration could activate the sensor(s) and deploy the air bag(s), possibly causing serious injury.
- When using air or electric power tools or hammers, always switch the Ignition OFF, disconnect the battery and wait at least three minutes before performing any service.

PREPARATION



< PREPARATION >

PREPARATION

PREPARATION

Commercial Service Tool

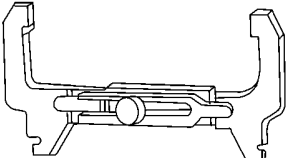
INFOID:000000011933989

Tool name	Description
<p>Brake drum clearance gauge</p>  <p>WFIA0167E</p>	<p>Measuring rear rotor drum inner diameter</p>
<p>Power tool</p>  <p>PIIB1407E</p>	<p>Loosening nuts, screws and bolts</p>

A

B

C

D

E

PB

G

H

I

J

K

L

M

N

O

P

PARKING BRAKE SHOE

< BASIC INSPECTION >

BASIC INSPECTION

PARKING BRAKE SHOE

Inspection

INFOID:000000012283546

LINING THICKNESS INSPECTION

- Check thickness of lining.

Standard thickness (new) (A) : Refer to [PB-14, "Parking Drum Brake"](#).

Wear limit thickness (A) : Refer to [PB-14, "Parking Drum Brake"](#).

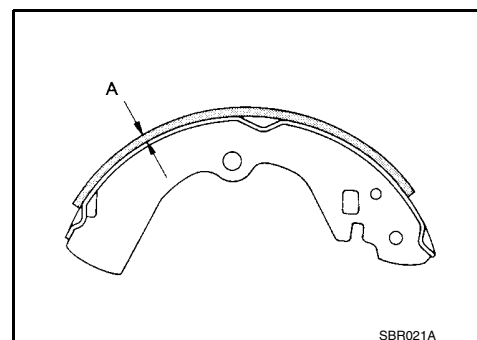

DRUM INNER DIAMETER INSPECTION

- Check inner diameter of drum in rear disc brake rotor using a suitable tool.

Standard inner diameter (new) : Refer to [PB-14, "Parking Drum Brake"](#).

Wear limit of inner diameter : Refer to [PB-14, "Parking Drum Brake"](#).

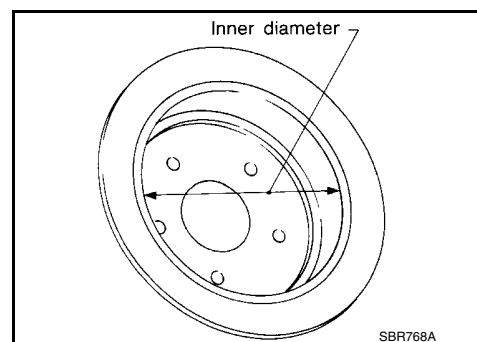

OTHER INSPECTIONS

- Check the following:
 - Lining for excessive wear, damage, and peeling.
 - Shoe sliding surface for excessive wear and damage.
 - Anti-rattle pin for excessive wear and corrosion.
 - Return spring for sagging.
- Make sure that adjuster moves smoothly.
- Visually check the inside of drum for excessive wear, cracks, and damage.
- Replace with new parts as necessary.

PARKING BRAKE SYSTEM

< PERIODIC MAINTENANCE >

PERIODIC MAINTENANCE

PARKING BRAKE SYSTEM

Inspection

INFOID:000000011933990

PEDAL STROKE

1. Operate parking brake pedal with a force of 196 N (20.0 kg-f, 44.1 lb-f). Check that pedal stroke is within specified number of notches. (Check it by listening and counting ratchet clicks.)

Number of notches : Refer to [PB-14, "Parking Brake Control"](#).

2. When brake warning lamp turns ON, check that pedal stroke is within specified number of notches. (Check it by listening to the clicks of the ratchet.)

Number of notches : Refer to [PB-14, "Parking Brake Control"](#).

Inspect Components

- Check each component for installation condition such as looseness.
- Check parking brake pedal assembly for bends, damage and cracks. Replace if necessary.
- Check cables for wear, damage and cracks. Replace if necessary.
- Check parking brake switch, and replace it if necessary. Refer to [PB-11, "Removal and Installation"](#).

Adjustment

INFOID:000000012203299

ADJUSTMENT

1. Remove instrument lower panel LH. Refer to [IP-23, "Removal and Installation"](#).
2. Release parking brake pedal by turning adjusting nut (A) with a deep socket wrench and loosening front cable (1).

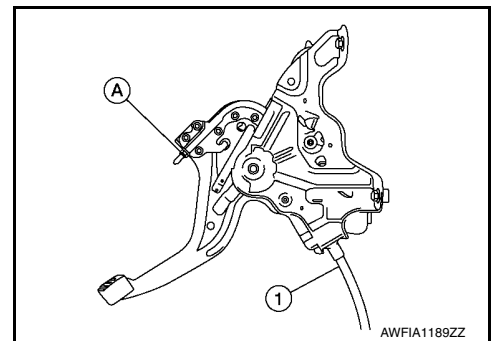

3. Remove wheels and tires using power tool. Refer to [WT-64, "Adjustment"](#).
4. Secure disc brake rotor using wheel nuts.
5. Remove adjusting hole plug from disc brake rotor. Turn adjuster (1) in direction (A) as shown using a suitable tool until disc brake rotor is locked.

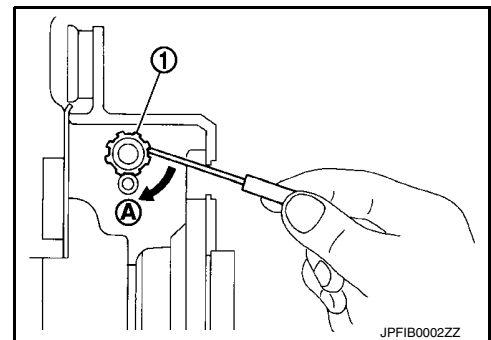

PARKING BRAKE SYSTEM

< PERIODIC MAINTENANCE >

6. Turn adjuster (1) back 5 or 6 notches from locked position in direction (B) as shown using a suitable tool.

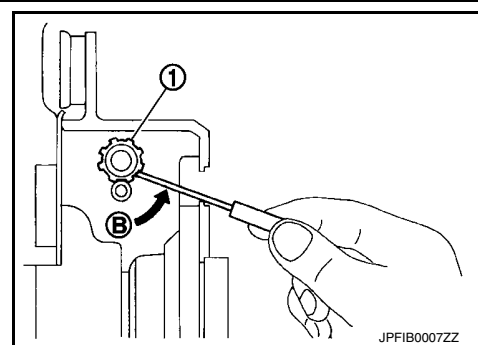

7. Rotate disc brake rotor to make sure there is no drag. Install adjusting hole plug.
8. Adjust cable with following procedure:
 - a. Operate parking brake pedal with a force of 490 N (50.0 kg-f, 110.2 lb-f) for more than 30 minutes.
 - b. Adjust parking brake pedal stroke by turning adjusting nut with deep socket wrench.
CAUTION:
Do not reuse the adjusting nut if it is removed.
 - c. Operate parking brake pedal with a force of 196 N (20.0 kg-f, 44.1 lb-f). Check that pedal stroke is within specified number of notches. (Check it by listening to the number of clicks of the ratchet.)

Number of notches : Refer to [PB-14, "Parking Brake Control"](#).

- d. Rotate disc brake rotor with parking brake pedal released and check that there is no drag.
CAUTION:
If any drag is found, verify the parking brake components are installed and adjusted correctly.
9. Install wheels and tires using power tool. Refer to [WT-64, "Adjustment"](#).
10. Install instrument lower panel LH. Refer to [IP-23, "Removal and Installation"](#).

PARKING BRAKE CONTROL

< REMOVAL AND INSTALLATION >

REMOVAL AND INSTALLATION

PARKING BRAKE CONTROL

Exploded View

INFOID:000000011933991

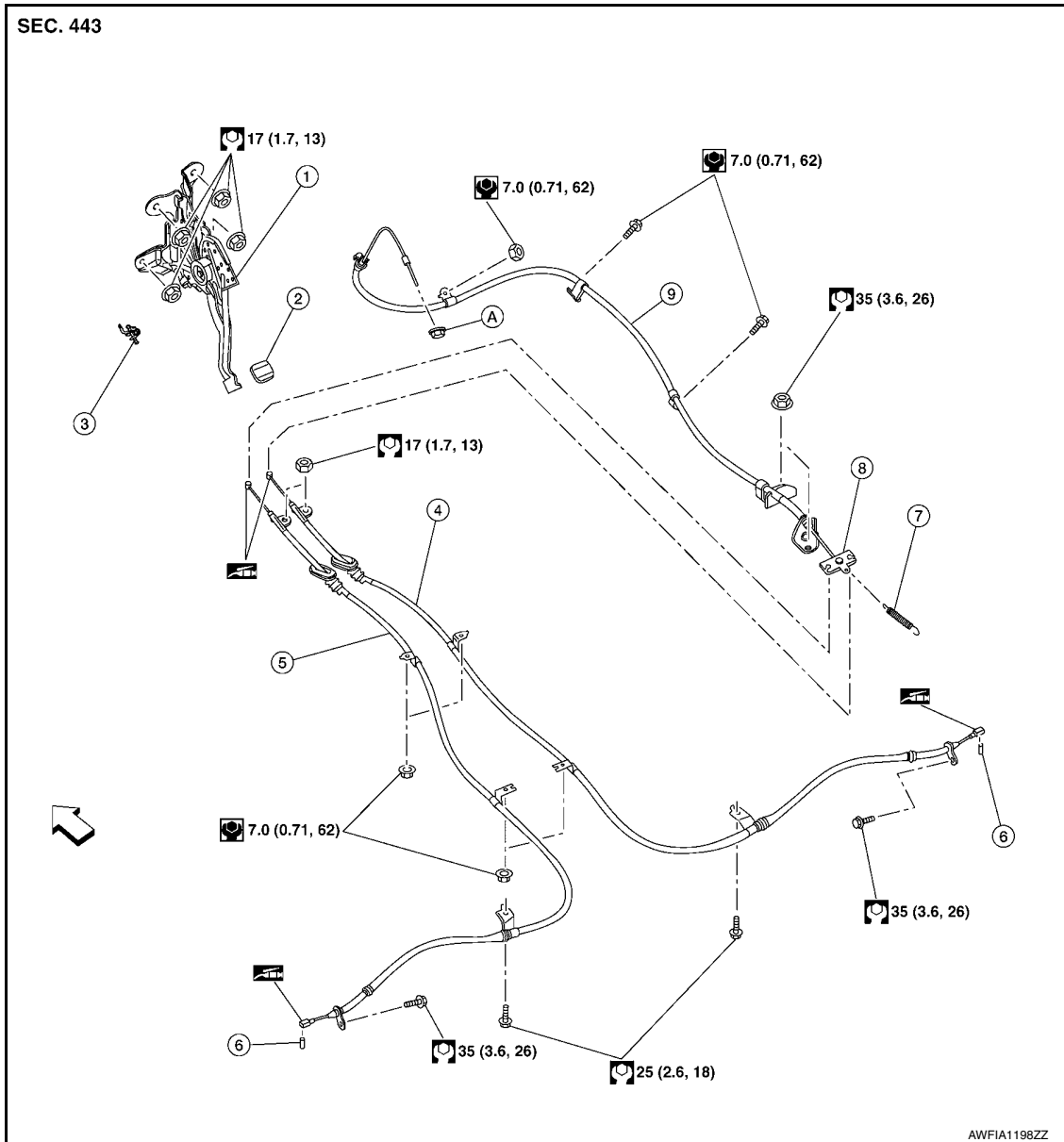

- | | | |
|------------------------|--------------------|-------------------------|
| 1. Parking brake pedal | 2. Pedal pad | 3. Parking brake switch |
| 4. Rear cable (RH) | 5. Rear cable (LH) | 6. Pin |
| 7. Spring | 8. Equalizer | 9. Front cable |
| A. Adjusting nut | ↔ Front | |

Removal and Installation

INFOID:000000011933992

REMOVAL

1. Remove instrument lower panel LH. Refer to [IP-23, "Removal and Installation"](#).
2. Remove lower knee protector. Refer to [IP-14, "Exploded View"](#).

PARKING BRAKE CONTROL

< REMOVAL AND INSTALLATION >

3. Disconnect harness connector from parking brake switch.
4. Remove parking brake switch.
5. Remove adjusting nut (A).

CAUTION:

Do not reuse adjusting nut.

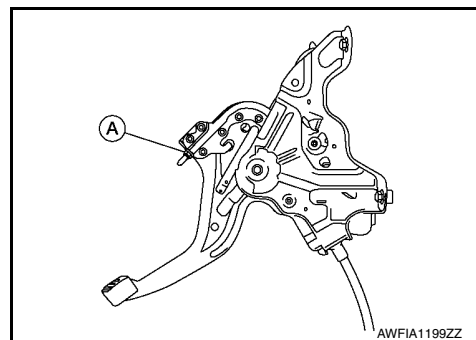

6. Remove parking brake control nuts and remove parking brake control.
7. Separate parking brake front cable from parking brake control.

INSTALLATION

Installation is in the reverse order of removal.

- Adjust parking brake. Refer to [PB-5, "Adjustment"](#).

CAUTION:

- **Do not reuse adjusting nut.**
- **The cables should be free from twists, damage, cracks, and corrosion.**

PARKING BRAKE FRONT CABLE

< REMOVAL AND INSTALLATION >

PARKING BRAKE FRONT CABLE

Removal and Installation

INFOID:000000012196538

REMOVAL

1. Remove parking brake control. Refer to [PB-7, "Removal and Installation"](#).
NOTE:
It is not necessary to remove parking brake switch.
2. Remove center console. Refer to [IP-20, "Removal and Installation"](#).
3. Place front floor trim (LH) aside. Refer to [INT-44, "Exploded View"](#).
4. Remove bolts from parking brake front cable. Refer to [PB-7, "Exploded View"](#).
5. Remove around view monitor control unit. Refer to [AV-273, "Removal and Installation"](#).
6. Remove spring from equalizer.
7. Pull equalizer (1) on parking brake front cable (2) in direction shown and separate parking brake rear cable (LH/RH) (3) from parking brake front cable.

CAUTION:

To prevent damage to parts, do not bend parking brake cables.

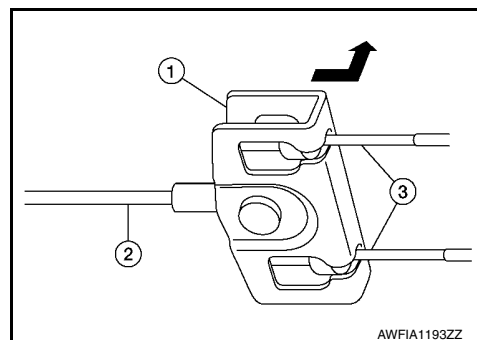

8. Remove parking brake front cable.

INSTALLATION

Installation is in the reverse order of removal.

CAUTION:

Do not reuse the adjusting nut.

- After installation, adjust parking brake pedal. Refer to [PB-5, "Adjustment"](#).

PARKING BRAKE REAR CABLE

< REMOVAL AND INSTALLATION >

PARKING BRAKE REAR CABLE

Removal and Installation

INFOID:000000012196539

REMOVAL

1. Remove center console assembly. Refer to [IP-20, "Removal and Installation"](#).
2. Loosen adjusting nut.
NOTE:
It is not necessary to remove parking brake front cable.
3. Pull equalizer (1) on parking brake front cable (2) in direction shown and separate parking brake rear cable (LH/RH) (3) from parking brake front cable.

CAUTION:

To prevent damage to parts, do not bend parking brake cables.

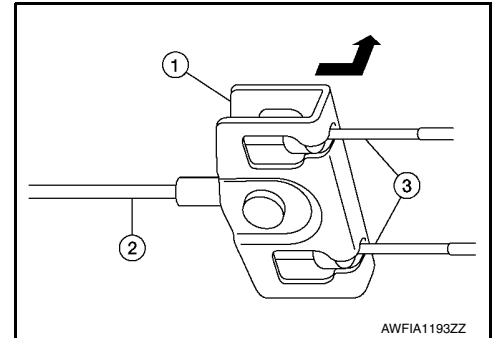

4. Remove center exhaust tube heat insulator.
5. Remove rear disc brake rotor. Refer to [BR-46, "DISC BRAKE ROTOR : Removal and Installation"](#).
6. Separate parking brake rear cable from toggle lever. Refer to [PB-12, "Exploded View"](#).
7. Remove bolts from rear parking brake cable.
8. Remove parking brake rear cable.

INSTALLATION

Installation is in the reverse order of removal.

CAUTION:

Do not reuse the adjusting nut if the nut is removed.

- After installation, adjust the parking brake shoes. Refer to [PB-13, "Break-In Procedure"](#).

PARKING BRAKE SWITCH

< REMOVAL AND INSTALLATION >

PARKING BRAKE SWITCH

Removal and Installation

INFOID:000000012196540

REMOVAL

1. Remove lower instrument panel LH. Refer to [IP-23, "Removal and Installation"](#).
2. Remove lower knee protector. Refer to [IP-14, "Exploded View"](#).
3. Remove parking brake control nuts and remove parking brake control.
4. Disconnect harness connector from parking brake switch.
5. Remove parking brake switch.

INSTALLATION

Installation is in the reverse order of removal.

CAUTION:

- **Replace parking brake switch if it has been dropped or sustained an impact.**
- **Do not reuse adjusting nut.**

A

B

C

D

E

PB

G

H

I

J

K

L

M

N

O

P

PARKING BRAKE SHOE

< REMOVAL AND INSTALLATION >

PARKING BRAKE SHOE

Exploded View

INFOID:000000011933993

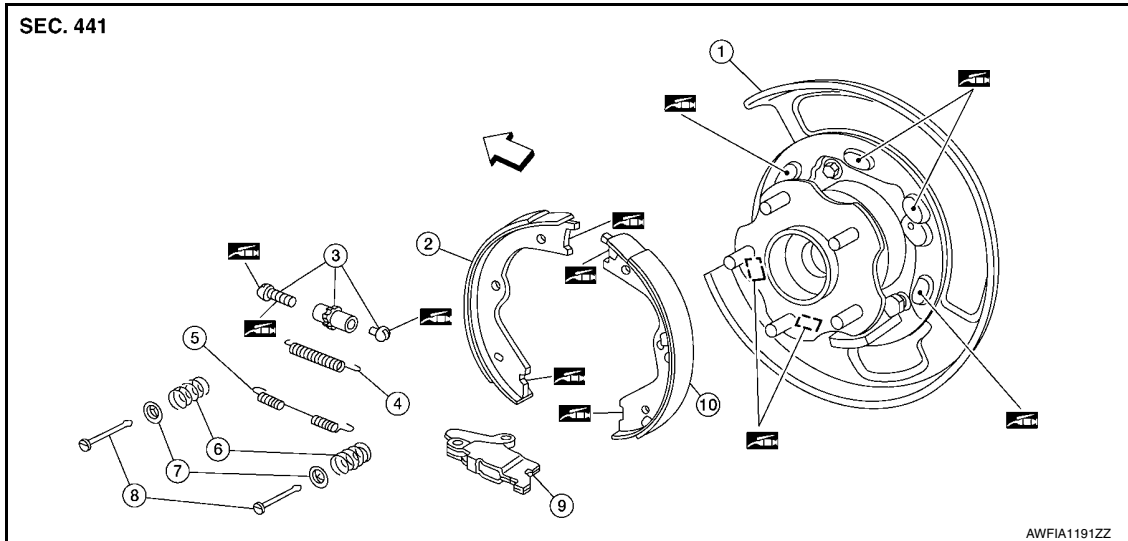

- | | | |
|-------------------------------|-------------------------------|-----------------------------------------------------------------|
| 1. Back plate | 2. Parking brake shoe (front) | 3. Adjuster |
| 4. Adjuster spring | 5. Return spring | 6. Anti-rattle spring |
| 7. Retainer | 8. Anti-rattle pin | 9. Toggle lever |
| 10. Parking brake shoe (rear) | ← Front | Apply PBC (Poly Butyl Cuprysil) grease or silicone based grease |

Removal and Installation

INFOID:000000011933994

REMOVAL

WARNING:

- Clean brakes with a vacuum dust collector to minimize the hazard of air borne particles or other materials.
- Clean dust on disc brake rotor and back plate using a vacuum dust collector. Do not blow with compressed air.

1. Remove rear wheels and tires using power tool. Refer to [WT-67, "Removal and Installation"](#).
2. Remove disc brake rotor. Refer to [BR-46, "DISC BRAKE ROTOR : Removal and Installation"](#).

CAUTION:

- Parking brake must be in the completely released position.
 - Put matching marks on both disc brake rotor and wheel hub when removing disc brake rotor.
3. If disc brake rotor cannot be removed, remove as follows:
 - a. Secure disc brake rotor with wheel nuts and remove adjuster hole plug.
 - b. Using suitable tool, rotate adjuster (1) in direction (B) to retract and loosen brake shoe as shown.

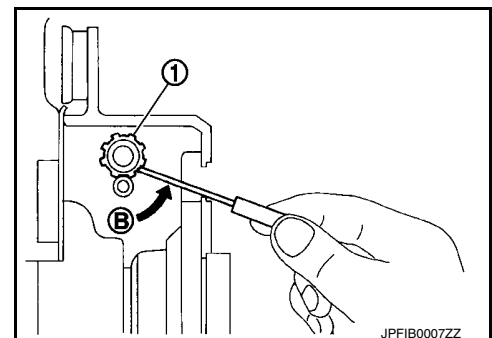

JPFIB0007ZZ

PARKING BRAKE SHOE

< REMOVAL AND INSTALLATION >

4. Remove anti-rattle pins, retainers, anti-rattle springs, return spring and adjuster spring.

CAUTION:

Do not drop the removed parts.

5. Remove parking brake shoes, adjuster, and toggle lever.

CAUTION:

- The parking brake shoes for the front side are made of different materials from those for the rear side. Do not misidentify them when removing.
- Do not drop the removed parts.

INSTALLATION

Installation is in the reverse order of removal.

- Assemble adjusters so that threaded part is expanded when rotating it in direction shown by arrow.

(A) : For LH brake

(B) : For RH brake

↶ : Front

← : Adjuster expanded

- Apply PBC (Poly Butyl Cuprysil) grease or silicone-based grease to back plate and brake shoe.

CAUTION:

The parking brake shoes for the front side are made of different materials from those for the rear side. Do not misidentify them when removing and replacing.

- Shorten adjuster by rotating it.
- When assembling the adjuster, apply PBC (Poly Butyl Cuprysil) grease or silicone-based grease to threads and pivot.
- Check parking brake shoe lining and drum inner surface for grease. Wipe off any grease on the surfaces.
- Inspect the parking brake shoes. Refer to [PB-4, "Inspection"](#).

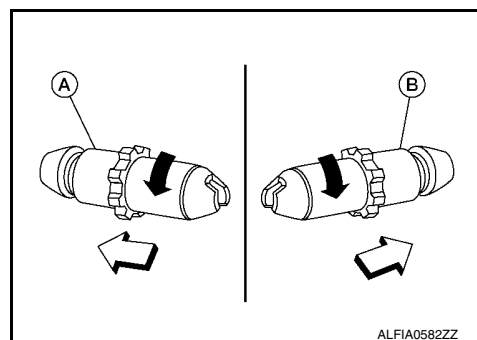

Break-In Procedure

INFOID:000000012196542

1. Perform parking brake break-in (drag on) operation by driving vehicle under the following conditions:
 - Drive forward.
 - Vehicle speed: Approx. 40 km/h (25 MPH) set (constant and forward)
 - Parking brake operating force: Approx. 200 +49.0, -0 N (20.4 +5, -0 kg-f, 45 +11, -0 lb-f)
 - Time: Approx. 5 +5, -0 seconds.

CAUTION:

To prevent lining from getting too hot, allow a cool off period of approximately 5 minutes after every break-in operation.

2. After break-in procedure, check parking brake pedal stroke.

CAUTION:

If it is out of specification, adjust again. Refer to [PB-5, "Adjustment"](#).

SERVICE DATA AND SPECIFICATIONS (SDS)

< SERVICE DATA AND SPECIFICATIONS (SDS)

SERVICE DATA AND SPECIFICATIONS (SDS)

SERVICE DATA AND SPECIFICATIONS (SDS)

Parking Drum Brake

INFOID:000000011933996

Unit: mm (in)

Brake lining	Standard thickness (new)	3.2 (0.126)
	Wear limit thickness	1.5 (0.059)
Drum (in disc)	Standard inner diameter (new)	172 (6.77)
	Wear limit of inner diameter	173 (6.81)

Parking Brake Control

INFOID:000000011933995

Control type	Foot pedal
Number of notches [under force of 196 N (20.0 kg-f, 44.1 lb-f)]	4 - 5
Number of notches when parking brake warning lamp turns on	1