

## 648H with Torque Converter—Grapple Skidder Dimensions

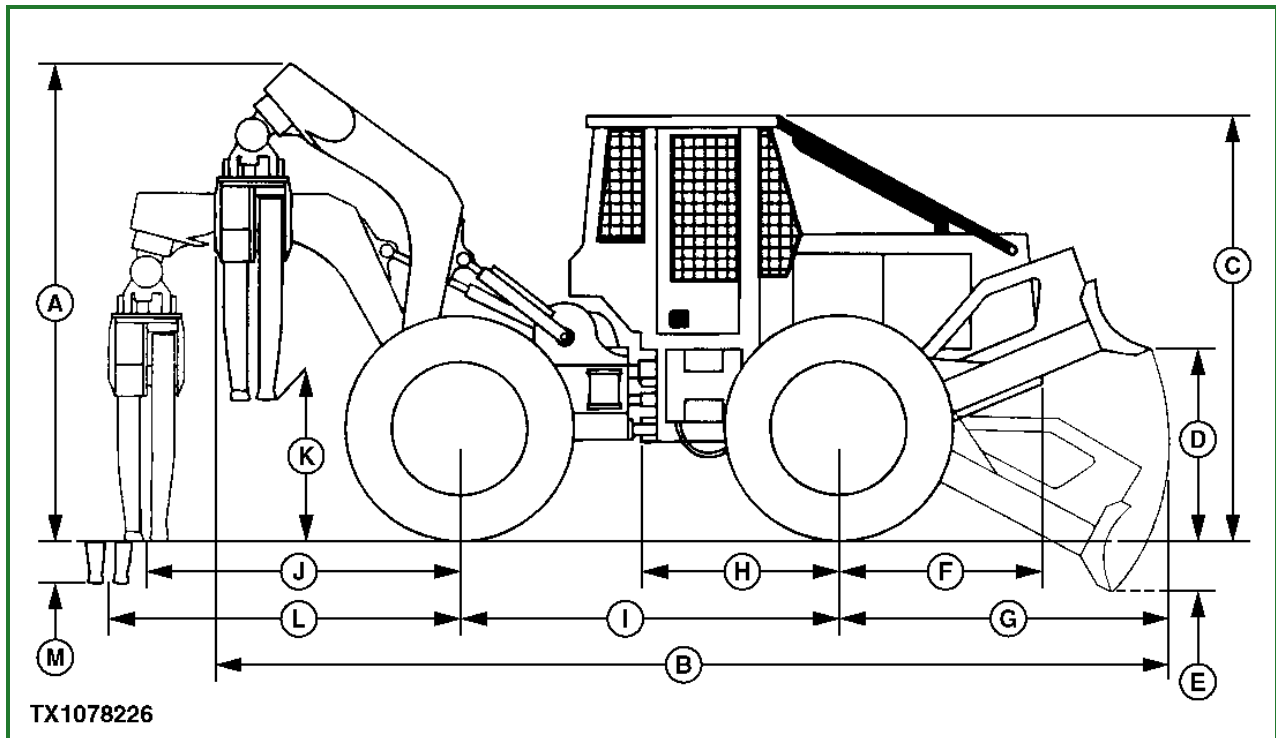

TX1078226-UN: Grapple Skidder Dimensions—Side View

**NOTE:**

Specifications and design subject to change without notice. Whenever applicable, specifications are in accordance with ISO and SAE standards. Except where otherwise noted, these specifications are based on a unit with roll-over protective structure, full fuel tank, 80 kg (175 lb) operator, and standard equipment.

**NOTE:**

Side view dimensions are for machine equipped with 30.5-32 12 PR LS2 tires and adjustable log arch.

Item	Measurement	Specification
A—Maximum Boom Height (Single Function)	Height	4188 mm 13 ft. 8.9 in.
A—Maximum Boom Height (Dual Function)	Height	4442 mm 14 ft. 6.9 in.
B—Overall Length (Single Function)	Length	7814 mm 25 ft. 7.6 in.
B—Overall Length (Dual Function)	Length	8068 mm 26 ft. 5.6 in.
C—Overall Height	Height	3127 mm 10 ft. 3.1 in.
C—Overall Height with Factory-Installed Water Tank	Height	3287 mm 10 ft. 9.4 in.
D—Maximum Blade Lift Above Ground	Height	1499 mm 5 ft. 11 in.
E—Maximum Blade Dig Below Ground	Depth	360 mm 1 ft. 2.2 in.
F—Front Axle to Front of Machine	Distance	1778 mm 5 ft. 10 in.
G—Front Axle To Blade Cutting Edge Arc	Distance	2558 mm 8 ft. 4.7 in.
H—Front Axle to Articulation Joint	Distance	1778 mm 5 ft. 10 in.
I—Wheelbase (Single Function)	Distance	3481 mm 11 ft. 5 in.
I—Wheelbase (Dual Function)	Distance	3735 mm 12 ft. 3 in.
J—Reach of Grapple at Ground Level (Single Function)	Distance	2961 mm 9 ft. 8.6 in.
J—Reach of Grapple at Ground Level (Dual Function)	Distance	3325 mm 10 ft. 10.9 in.
K—Height of Grapple from Ground Level (Single Function)	Height	1575 mm 5 ft. 2 in.
K—Height of Grapple from Ground Level (Dual Function)	Height	1829 mm 6 ft.
L—Reach of Grapple at Full Reach (Single Function)	Distance	2580 mm 8 ft. 5.6 in.
L—Reach of Grapple at Full Reach (Dual Function)	Distance	2834 mm 9 ft. 3.6 in.
M—Below Ground Reach of Grapple at Full Reach (Single Function)	Depth	907 mm 2 ft. 11.7 in.
M—Below Ground Reach of Grapple at Full Reach (Dual Function)	Depth	1161 mm 3 ft. 9.7 in.