

Standard Z-Bar Specifications

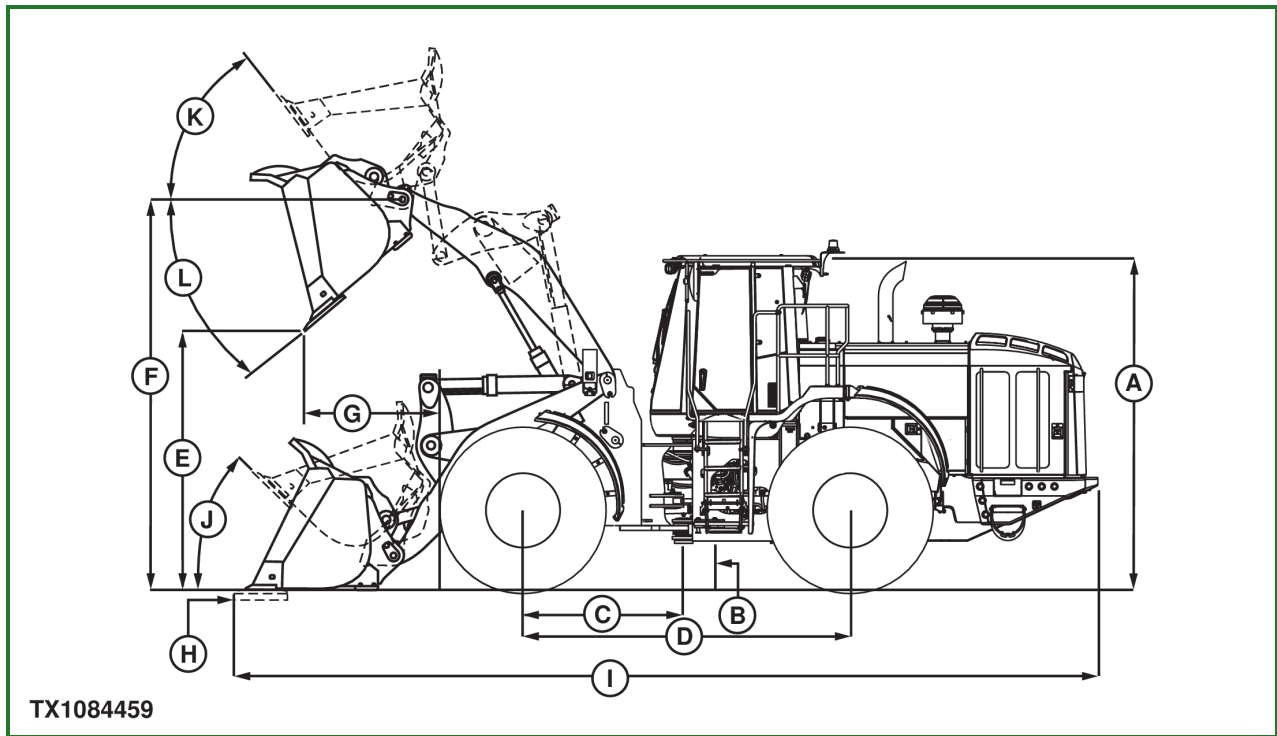

TX1084459-UN: Standard Z-Bar Specifications

LEGEND:

- A - Overall Machine Height
- B - Machine to Ground Clearance
- C - Centerline to Front Axle Length
- D - Wheelbase Length
- E - Dump Clearance Height
- F - Bucket Hinge Height
- G - Dump Reach
- H - Maximum Digging Depth
- I - Overall Machine Length
- J - Maximum Rollback at Ground Level
- K - Maximum Rollback at Full Height
- L - Bucket Dump at Full Height

NOTE:

Specifications and design subject to change without notice. Wherever applicable, specifications are in accordance with ISO standards. Loader operating information is based on machine with identified linkage and standard equipment, ROPS cab, rear cast bumper/counterweight, transmission side-frame guards, bottom guards, standard tires, full fuel tank, 5.25 cu. yd. (4.0 m³) general purpose bucket with bolt-on edge, and 175-lb. (79 kg) operator. This information is affected by changes in tires, ballast, and different attachments.

Item	Measurement	Specification
A—Overall Machine	Height	3.50 m 11 ft. 6 in.
B—Machine to Ground	Clearance	462 mm 1 ft. 6 in.
C—Centerline to Front Axle	Length	1.70 m 5 ft. 7 in.
D—Wheelbase	Length	3.46 m 11 ft. 4 in.
E—Dump Clearance	Height	3.04 m 10 ft. 0 in.
F—Bucket Hinge	Height	4.28 m 14 ft. 1 in.
G—Dump	Reach	1.23 m 4 ft. 0 in.
H—Maximum Digging Depth	Depth	80 mm 3.2 in.
I—Overall Machine	Length	9.01 m 29 ft. 7 in.
J—Maximum Rollback at Ground Level	Angle	40°
K—Maximum Rollback at Full Height	Angle	55°
L—Bucket Dump at Full Height	Angle	49°
Overall Machine	Weight	24 182 kg 53 312 lb

DP99999,0000165-19-20101111