

External Service Brake Inspection

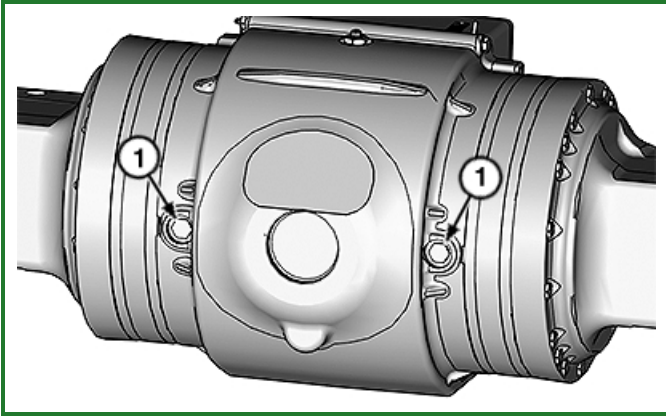

TX1162996A-UN: Brake Inspection Ports



TX1030355A-UN: Brake Disc Linings

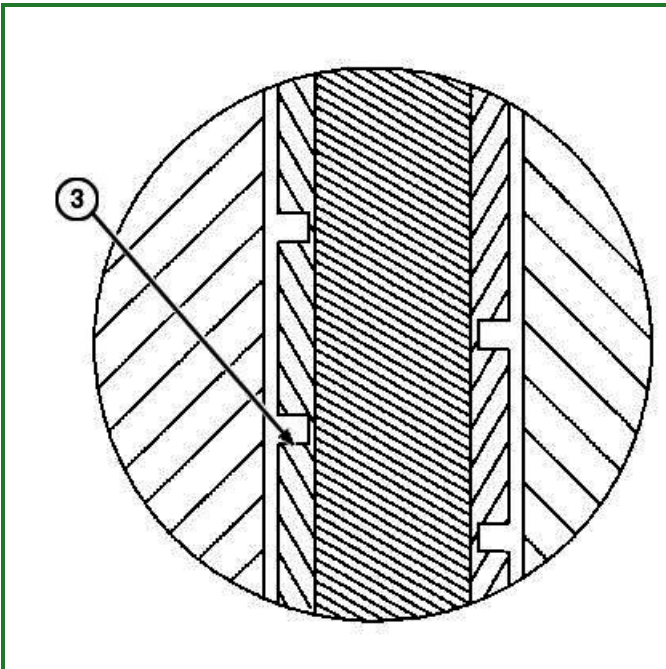

TX1015685A-UN: Brake Lining Oil Grooves

LEGEND:

- 1 - Inspection Port Plug (2 used)
- 2 - Brake Lining (2 used)
- 3 - Oil Groove

⚠ CAUTION:

Prevent possible injury from hot spraying oil. Slowly loosen plug to relieve any air pressure.

IMPORTANT:

Check both front and rear axle during each inspection.

Perform first inspection at 5000 hours followed by 1000 hour inspection intervals after the first 5000 hour inspection.

If the service brakes are subjected to severe duty, inspect more frequently.

1. Remove brake inspection port plugs (1).
2. Inspect the brake linings (2) on brake disc.
3. If oil grooves (3) on linings are no longer visible, brake discs must be replaced. See your John Deere dealer.

WC20922,0004F74-19-20140624