

Machine Specifications

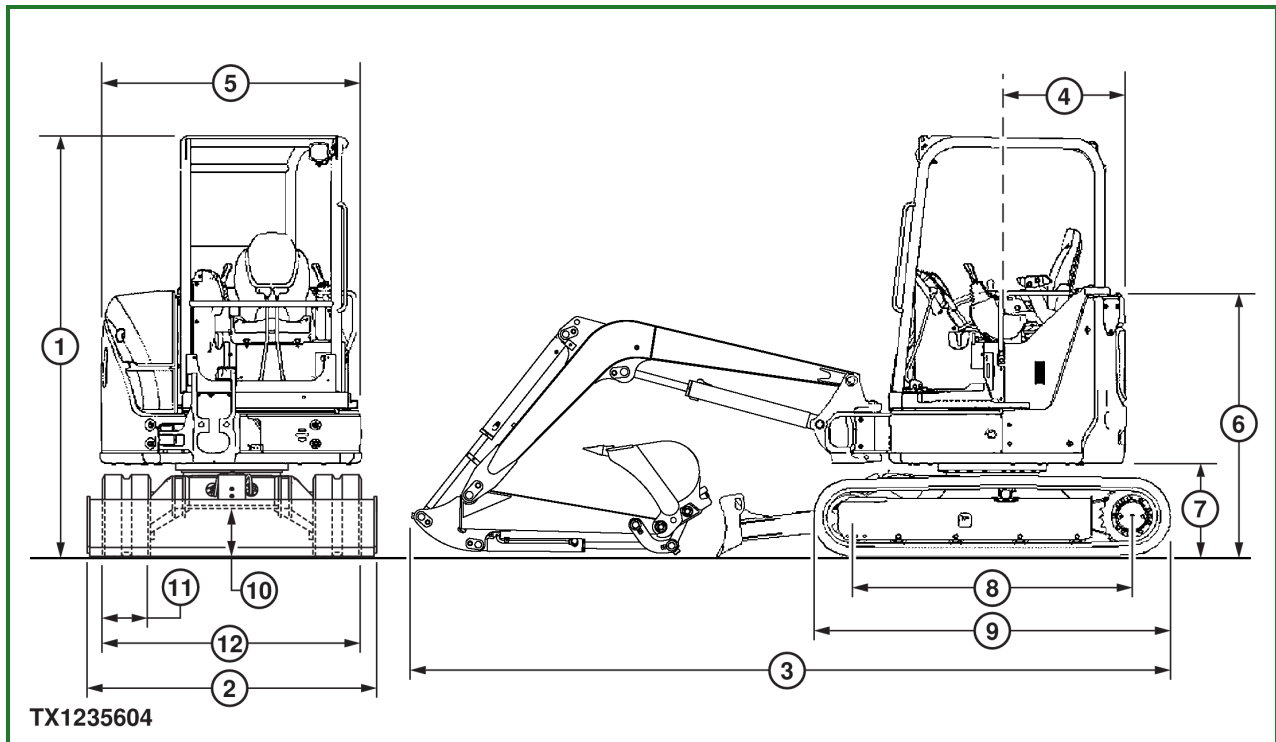

TX1235604-UN: Machine Specifications (canopy machine shown)

LEGEND:

- 1 - Machine Transport Height
- 2 - Machine Overall Width
- 3 - Machine Transport Length
- 4 - Rear End Swing Radius
- 5 - Upperstructure Width
- 6 - Engine Cover Height
- 7 - Counterweight Clearance
- 8 - Sprocket Center to Idler Center Distance
- 9 - Undercarriage Length
- 10 - Minimum Ground Clearance
- 11 - Track Width
- 12 - Undercarriage Width

NOTE:

Specifications and design are subject to change without notice. Wherever applicable, specifications are in accordance with PCSA and SAE standards. Except where otherwise noted, these specifications are based on a machine equipped with rubber track, 328 kg (723 lb) counterweight, 1.17 m (3 ft 10 in) arm, 81.5 kg (180 lb) bucket, full fuel tank, 79 kg (175 lb) operator, and standard equipment.

Item	Measurement	Specification
1—Machine Transport	Height	2480 mm 8 ft 2 in
2—Machine	Overall Width	1740 mm 5 ft 9 in
3—Machine Transport	Length	4450 mm 14 ft 7 in
4—Rear End Swing	Radius	775 mm 2 ft 7 in
5—Upperstructure	Width	1550 mm 5 ft 1 in
6—Engine Cover	Height	1530 mm 5 ft 0 in
7—Counterweight	Clearance	550 mm 1 ft 10 in
8—Sprocket Center to Idler Center	Distance	1660 mm 5 ft 5 in
9—Undercarriage	Length	2110 mm 6 ft 11 in
10—Minimum Ground	Clearance	280 mm 0 ft 11 in
11—Track	Width	300 mm 1 ft 0 in
12—Undercarriage	Width	1550 mm 5 ft 1 in
Blade	Height	373 mm 1 ft 3 in
Blade	Width	1740 mm 5 ft 9 in
Machine		
Canopy	Operating Weight (approximate)	3105 kg 6845 lb
Cab	Operating Weight (approximate)	3275 kg 7220 lb

KR46761,00014E8-19-20170329