





Pump Assembly

Special Tool(s)

 <p>ST1189-A</p>	<p>Installer, Front Pump Fluid Seal 307-014 (T63L-77837-A)</p>
 <p>ST1187-A</p>	<p>Slide Hammer 307-005 (T59L-100-B)</p>
 <p>ST1664-A</p>	<p>Banding Tool, Transmission Pump 307-D004 (D89L-77000-A) or equivalent</p>
 <p>ST1213-A</p>	<p>Remover, Bushing 307-001 (TOOL-1175-AC) or equivalent</p>
 <p>ST1274-A</p>	<p>Depth Micrometer 303-D026 (D80P-4201-A) or equivalent</p>

Material

Item	Specification
<p>Motorcraft MERCON® Multi-Purpose (ATF) Transmission Fluid XT-2-QDX</p>	<p>MERCON®</p>

Pump Assembly, Disassembled View

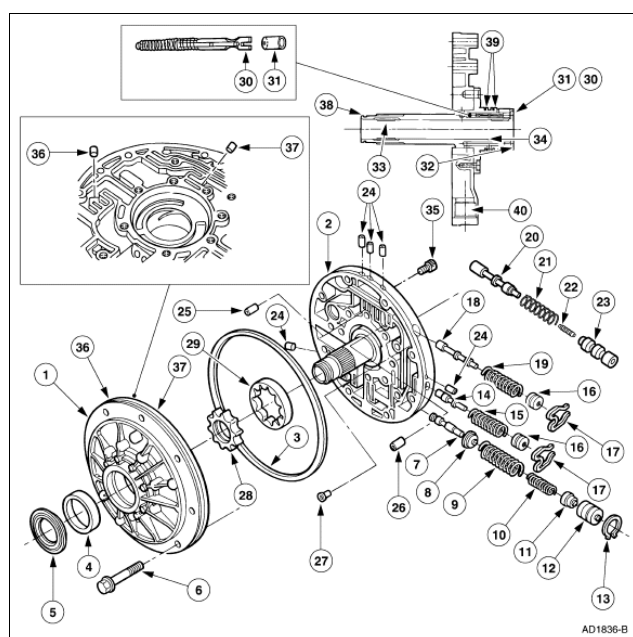

2003 E-Series Workshop Manual

Item	Part Number	Description
1		Pump body (part of 7A103)
2		Control body (part of 7A103)
3	7A248	Square-cut front pump seal
4		Converter hub bushing
5	7A248	Front pump seal
6	N805260-S	Bolt and washer assembly (9 req'd)
7		Main regulator valve (part of 7A103)
8		Spring retainer (part of 7A103)
9		Outer spring (part of 7A103)
10		Inner spring (part of 7A103)
11	7D003	Main regulator booster valve
12		Main regulator booster sleeve (part of 7D003)
13		Retainer clip (part of 7A103)
14		Converter regulator valve (part of 7A103)
15		Spring (part of 7A103)
16		End plug (part of 7A103)
17		Retainer clip (part of 7A103)
18		Converter clutch control valve (part of 7A103) (gasoline application)
19		Spring (part of 7A103) (gasoline application)
20		Converter clutch control valve (part of 7A103) (diesel application)
21		Spring (part of 7A103) (diesel application)
22		Valve (part of 7A103) (diesel application)
23		Main regulator valve (part of 7A103) (diesel application)
24		Solid cup plug (part of 7A103)
25		Orificed cup plug (part of 7A103)
26		Orificed cup plug (part of 7A103)
27		Air bleed check valve assembly (part of 7A103)
28		Inner gerotor gear (part of 7A103)
29		Outer gerotor gear (part of 7A103)
30		Orifice cup plug (part of 7H132)
31	7H132	Spring and stop assembly
32		Orifice cup plug (part of 7A103)
33		Front input shaft bushing (part of 7A103)
34		Rear input shaft bushing (part of 7A103) or bearing (model dependent)
35		Bolt, M8 (11 req'd) (part of 7A103)
36		Orificed cup plug (part of 7A103)
37		Orificed cup plug (part of 7A103)
38	7L323	Front pump stator support seal
39	7G402	Coast clutch seal (2 req'd)

40	Inlet tube bore (part of 7A103)
----	---------------------------------

Disassembly

⚠ CAUTION: The pump assembly is model dependent. Failure to use the correct pump may cause transmission assembly damage; refer to the parts catalog for the correct pump.

1. **NOTE:** Inspect and replace the front pump seal, if damaged.

Using the special tools, remove the front pump seal.

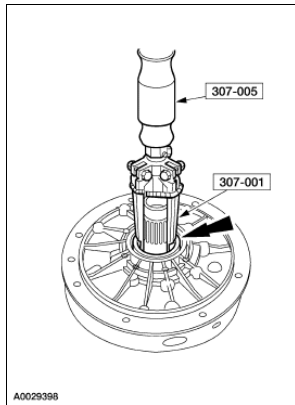

2. Remove the front pump stator support seal.

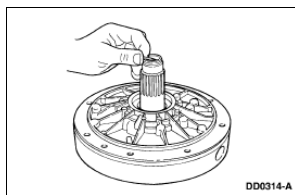

3. Remove the two Teflon® coast clutch seals.

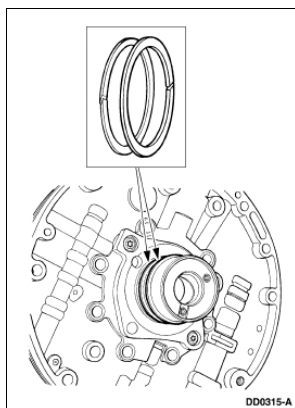

4. Remove the pump outer diameter square-cut front pump seal.

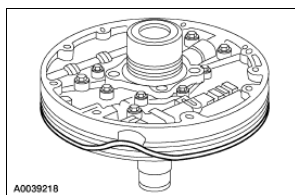

5. **⚠ CAUTION: Do not reuse the orifice cup plug or spring and stop assembly. Failure to replace these parts may cause repeat repairs. Make sure the old rubber stop is removed (it may become separated from the spring assembly).**

⚠ CAUTION: Use care not to damage any machined surfaces of the stator support.

Remove and discard the orifice cup plug and the spring and stop assembly. Clean and inspect the bore, making sure it is clean of any debris.

1. Remove the orifice cup plug.
2. Remove the spring and stop assembly.
3. Remove the old rubber stop.

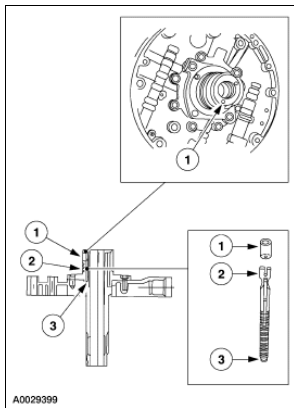

6. Remove 12 bolts and separate the pump control body from the pump body.

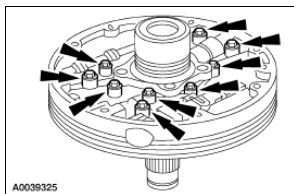

7. **⚠ CAUTION: Do not remove any of the remaining cup plugs unless directed to do so in other steps. Do not remove the stator support from the control body. This can distort the surface of the control body.**

NOTE: Inspect the main regulator booster valve and sleeve assembly. If the pump valve bore is not damaged but the valve and sleeve are worn, replace the valve and sleeve. For additional information, refer to Pump Assembly, Disassembled View.

Remove the converter clutch shift valve assembly, converter regulator valve assembly, and main regulator boost valve and sleeve assembly.

1. For diesel application, remove the retainer clip with a small screwdriver or tweezers then remove the converter clutch shift valve assembly.
2. For gasoline application, remove the retainer clip with a small screwdriver or tweezers then remove the converter clutch shift valve assembly.
3. Remove the retainer clip with a small screwdriver or tweezers then remove the converter regulator valve assembly.
4. Remove the retainer clip with a small screwdriver or tweezers then remove the main regulator valve assembly.

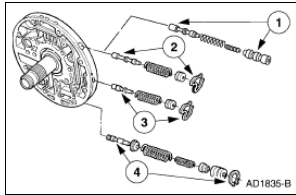

8. Remove and inspect the inner and the outer gerotor gears.

- Clean all pump parts in solvent.
- Dry the parts with compressed air.
- Inspect the pump gears, faces, gear teeth, pump housing and mating surfaces for damage or scoring.
- Replace the entire pump if any part is damaged or worn.

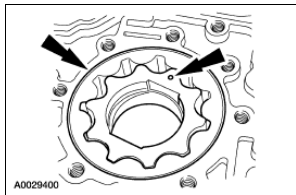

9. Inspect the converter hub bushing. If scored or excessively worn, replace the entire pump. Note the orientation of the lube groove.

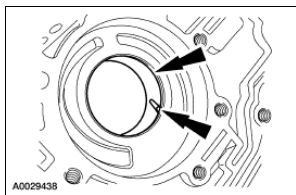

10. **NOTE:** The pump assemblies are model-dependent. Refer to the parts catalog for correct usage.

Inspect the front and the rear input shaft bushing. If the bushing is worn or scored install a new pump.

1. Front input shaft bushing.
2. Rear input shaft bushing.

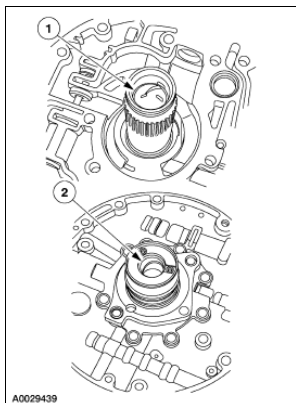

11. **NOTE:** The pump assemblies are model-dependent. Refer to the parts catalog for correct usage.

Remove the coast clutch seals and discard.

1. Inspect the bushing for wear. If scored or worn, replace the entire pump.
2. Remove the coast clutch seals.

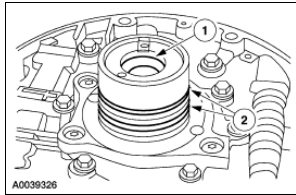

12. Measure and record the depth of the inner, then the outer, pump gerotor gear face-to-pump body machined surface.
1. Place the pump gerotor gearset into the pump gear pocket and center it to the pump bushing diameter.
 2. Using the special tool, measure and record the depth of the inner gerotor gear face to the pump body machined surface. Repeat measurement for a total of three readings in equally spaced locations on the gear face. If the reading is not within specification, replace the front pump assembly.
 3. Remove the inner gear and reinstall the outer gear. Repeat Substep 2 for the outer gerotor gear face.

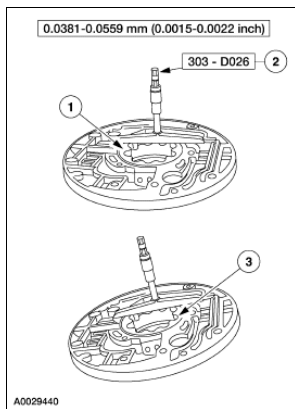

13. Inspect the following:
- All valve and plug bores for scoring or damage.
 - All passages for obstructions.
 - Mating surfaces for burrs and scoring.
 - All springs for distortion.
 - When dry, check all valves and plugs for free movement in their respective bores.

Assembly

1. Install the main regulator valve and sleeve assembly, converter clutch shift valve assembly, and the converter regulator valve assembly.
 1. For diesel application, install the converter clutch control valve assembly. Then apply pressure to the end plug and install the retainer, making sure it is correctly seated.
 2. For gasoline application, install the converter clutch control valve assembly. Then apply pressure to the end plug and install the retainer, making sure it is correctly seated.
 3. Install the converter regulator valve assembly. Then apply pressure to the end plug and install the retainer, making sure it is correctly seated.
 4. Install the main regulator boost valve and sleeve assembly. Then apply pressure to the main regulator booster sleeve and install the retainer, making sure it is correctly seated.

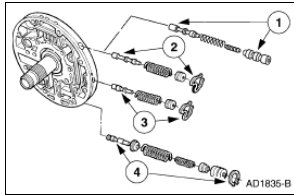

2. **NOTE:** Prior to installation, lightly lubricate the gerotor gears with clean automatic transmission fluid.

Install the gerotor gearset, with the dot facing the control body assembly.

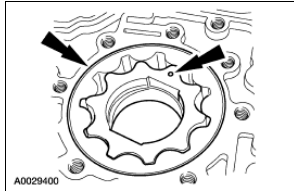

3. **⚠ CAUTION:** Prior to pump assembly, make sure all cup plugs are installed.

⚠ CAUTION: Inspect mating surfaces of the pump body and the control body to make sure they are clean and free of nicks and burrs.

Assemble the control body and stator assembly onto the pump body, aligning the 28 mm (1.12 in) hole in each body.

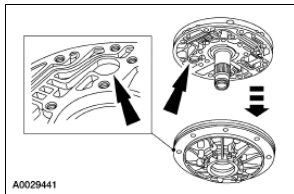

4. **NOTE:** Make sure that the outer edges of the pump body and the outer bolt holes are aligned during assembly.

Using the special tool, assemble the pump and loosely install 11 bolts.

1. Install the 10 mm (0.4 in) alignment bolt.
2. Tighten the bolts.

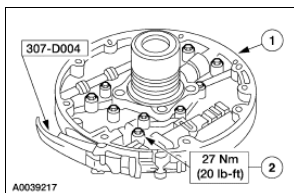

5. **⚠ CAUTION:** Make sure the seal grooves in the stator support are clean and free of burrs.

⚠ CAUTION: Make sure the seal ends are correctly positioned together and not separated.

Install the 2 coast clutch Teflon® seals. Make sure the seals are fully seated in the stator support seal grooves and the seal ends are oriented 180 degrees apart.

1. Correct position of the seal ends.

2. Incorrect position of the seal ends.
3. Seals need to be installed 180 degrees apart.

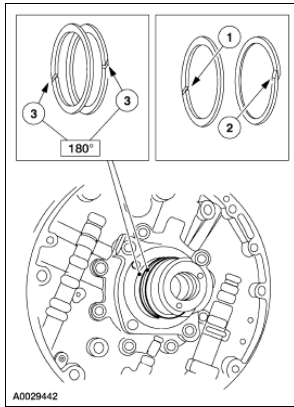

6. Install the pump outer diameter square-cut front pump seal.

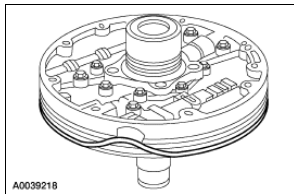

7. Install the front pump stator support seal.

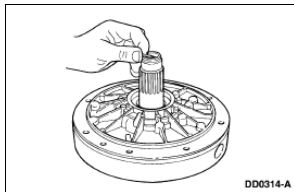

8. **⚠ CAUTION: Failure to replace these parts may cause repeat repairs.**

NOTE: Install the rubber stop end into the bore first.

Install the new spring and stop assembly.

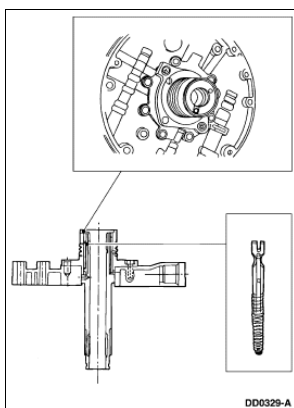

9. **NOTE:** Make sure the edge of the cup plug is seated just below the stator support surface that mates with the No. 2 needle bearing assembly.

Using a small drift and mallet, install the new orifice cup plug.

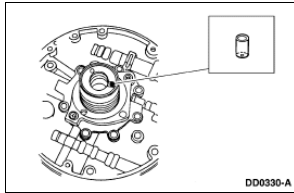

10. If removed, install the front pump seal, using the special tool.

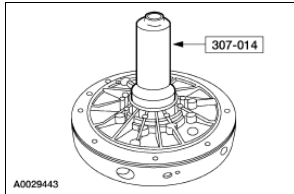

11. **NOTE:** The No. 1 pump thrust washer is model dependent.



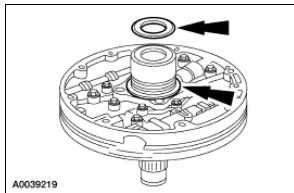

NOTE: Lightly lubricate the thrust washer and the bearing with petroleum jelly to hold them in place during assembly.

Install the No. 1 pump thrust washer and the No. 2A overdrive sun gear thrust bearing.

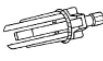

Front Case Bushings

Special Tool(s)

 ST1185-A	Slide Hammer 100-001 (T50T-100-A)
 ST1060-A	Drawbar, (Heavy Duty Threaded) 204-029 (T77F-1176-A)
 ST1213-A	Remover, Bushing 307-001 (TOOL-1175-AC) or equivalent
 ST1856-A	Installer, Transmission Extension Housing Bushings 307-258 (T92T-77110-AH)

Disassembly

- Using the special tools, remove the front case bushing.

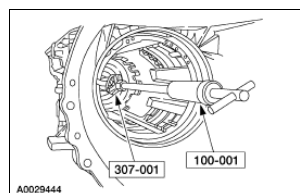

Assembly

- NOTE:** The front case bushing has three lube grooves. The rear case bushing has one lube groove.

Install the front case bushing onto the special tool.

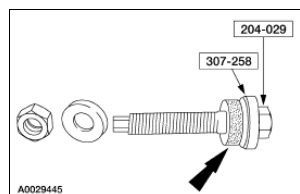

- Place the special tool with the front case bushing through the case and into the rear case bushing.

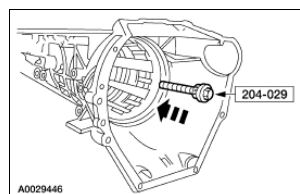

- CAUTION:** Make sure the bushing and tool are centered in the bore.

Install the special tool then, install the washer and the nut hand-tight.

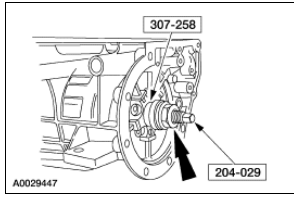

4. Hold the special tool while turning the nut until the front case bushing is fully seated. Remove the tools.

