

142. Remove the block heater.

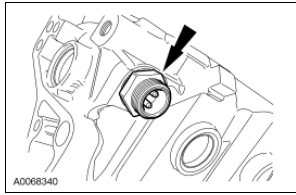

143. Remove the 20 lower crankcase bolts and the lower crankcase assembly.

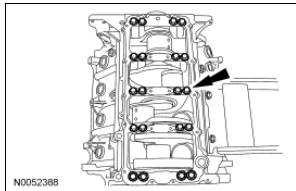

144. **NOTE:** Clean and inspect the gasket. Install a new gasket if necessary.

Remove the lower crankcase bearings and discard.

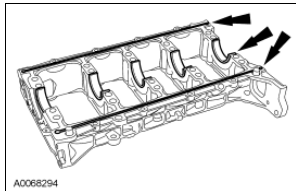

145. Using the appropriate lifting device, remove the crankshaft assembly.

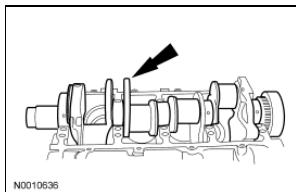

146. Remove and discard the crankshaft upper bearings and crankshaft upper thrust bearing.

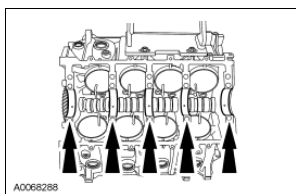

147. **⚠ CAUTION: Do not nick or scratch the camshaft bearings with the camshaft lobes or engine damage will occur.**

Remove the thrust plate mounting bolts and remove the camshaft and gear.

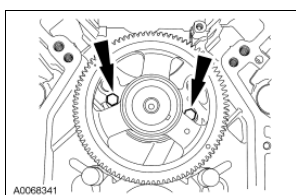

148. ⚠ **CAUTION:** This patch bolt is unique — do not substitute or engine damage can occur.

Remove the bolts and the 8 piston cooling tubes.

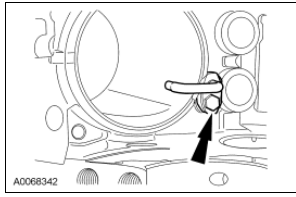

149. Using the special tool, remove the camshaft bearings and discard.

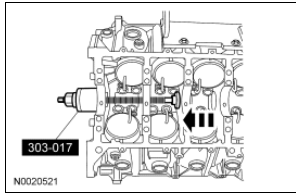

**Cylinder Head**  [Printable View \(274 KB\)](#)**Disassembly and Assembly**

1. Install the Valve Spring Compressor.

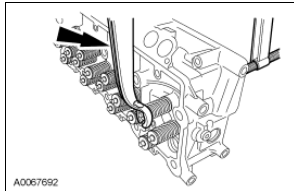

2. **NOTE:** If necessary, strike the valve stem end with a plastic-tipped hammer to loosen the valve spring retainer keys.

Remove the valve spring retainer keys.

1. Remove the valve spring retainer keys.
2. Remove the valve spring compressor.

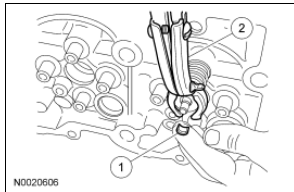

3. Remove the valve spring rotator.

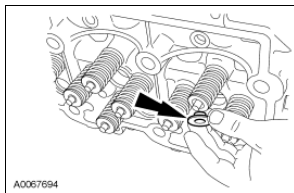

4. Remove the valve spring.

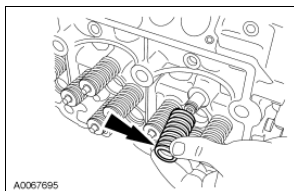

5. Remove the valve.

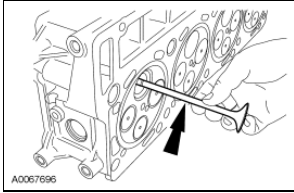

6. Remove the valve stem seal.

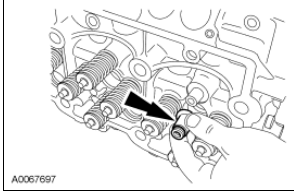

7. To assemble, reverse the disassembly procedure.

---

**Piston**  [Printable View \(112 KB\)](#)**Disassembly and Assembly**

1. **NOTE:** Mark the connecting rod and piston to make sure correct orientation on reassembly.

Remove the piston pin retainers.

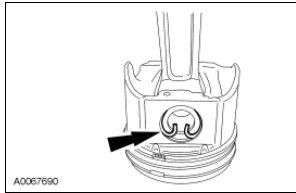

2. **NOTE:** The piston pins are a floating type piston pin and should not require a press to remove or install them.

Remove the connecting rod.

1. Remove the piston pin.
2. Remove the connecting rod.

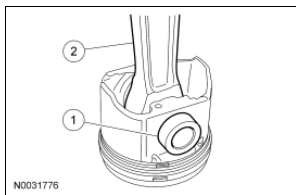









3. To assemble, reverse the disassembly procedure.
-



**Engine**  [Printable View \(5040 KB\)](#)

Special Tool(s)

 ST2697-A	Lifting Bracket, Cylinder Head 303-759
 ST2705-A	Installer, Crankshaft Front Seal and Wear Ring 303-761
 ST1214-A	Dial Indicator with Bracketry 100-002 (D78P-4201-B) or equivalent
 ST1381-A	Service Set, Camshaft 303-017 (T65L-6250-A)
 ST2696-A	Alignment Tool, Camshaft 303-772
 ST2691-A	Remover/Installer Glow Plug Connector 303-1114
 ST2859-A	Socket, Injection Pressure Regulator (IPR) Valve 303-1112
 ST2702-A	Installer, Crankshaft Rear Seal and Wear Ring 303-770
 ST1376-A	Piston Ring Compressor 303-D032 (D81L-6002-C)

Material

Item	Specification
SAE 15W-40 Super Duty Diesel Motor Oil XO-15W40-QSD (US); CXO-15W40-LSD12 (Canada); or equivalent	WSS-M2C171-D
RTV Silicone Sealant TA-31	—
Threadlock 262 TA-26	WSK-M2G351-A6
	ESE-M12A4-A

High Temperature Nickel Anti-Seize Lubricant XL-2 (US); CXG-2-B (Canada)	
--	--

**6.0L Crankshaft, Camshaft and Piston**

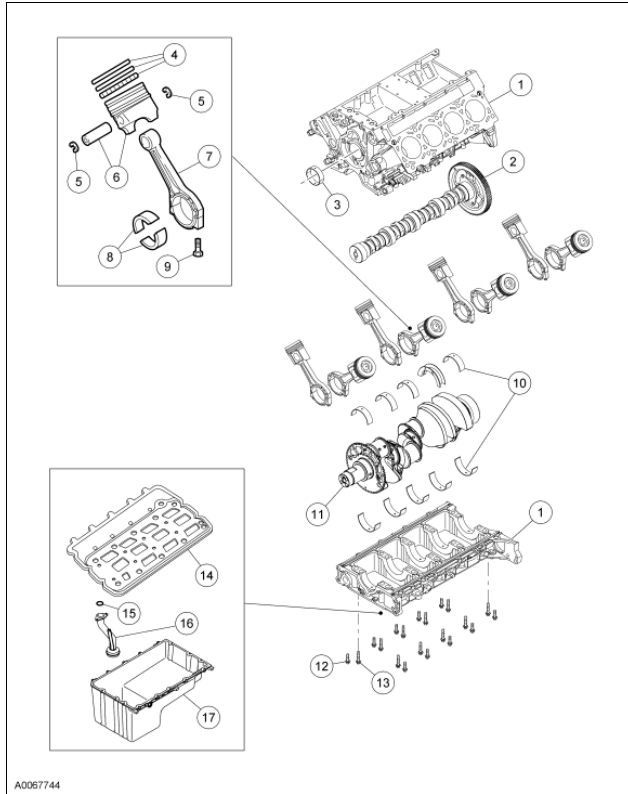

Item	Part Number	Description
1	6010	Cylinder block assembly
2	6250	Camshaft assembly
3	6A251	Camshaft bearing kit
4	6148	Piston ring kit
5	6140	Piston pin retaining rings
6	6102	Piston pin and piston
7	6200	Connecting rod and cap assembly
8	6B237	Connecting rod bearing kit
9	6214	Connecting rod bolt
10	6333	Crankshaft bearing kit
11	6303	Crankshaft assembly
12	6345	Main bearing bolt, M14 x 2 x 114.5
13	6345	Main bearing bolt, M14 x 2 x 127.5
14	6675	Upper oil pan assembly
15	6626	Oil pump cover-to-inlet tube flange
16	6622	Oil pump screen cover and tube
17	6676	Lower oil pan assembly



**6.0L Front Cover, Rear Cover and Oil Components**

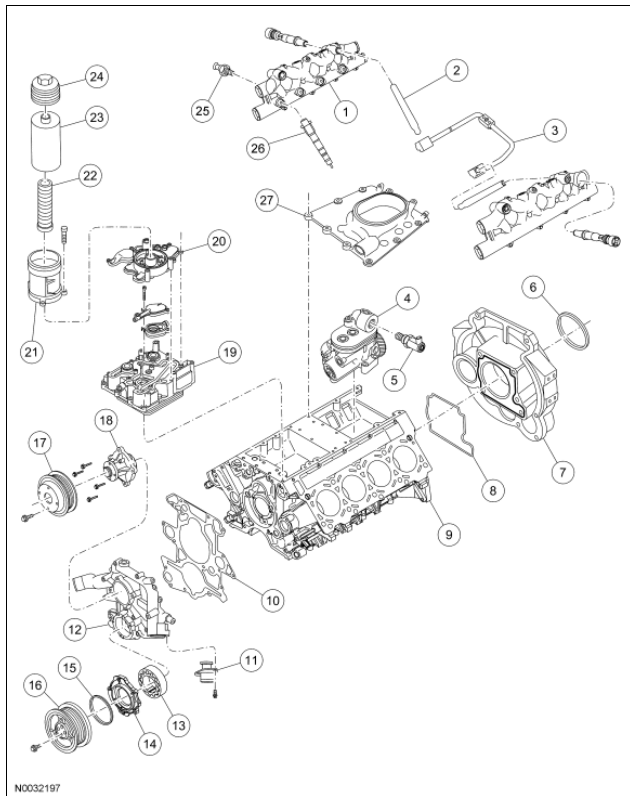

Item	Part Number	Description
1	9D280	Fuel injector manifold assembly
2	9A332	Crankcase-to-head tube assembly
3	9J332	Rear engine tube assembly
4	9A543	Fuel injector pump assembly
5	9C968	Injection pressure regulator valve
6	6701	Crankshaft rear oil seal assembly
7	6L080	Engine rear cover assembly
8	6D083	Engine rear cover gasket
9	6010	Cylinder block assembly
10	6020	Cylinder front cover gasket
11	8575	Water thermostat assembly
12	6019	Cylinder front cover assembly
13	6608	Oil pump drive rotor and shaft assembly
14	6616	Oil pump body
15	6700	Crankcase front oil seal
16	6316	Crankshaft vibration damper
17	8509	Water pump pulley assembly
18	8501	Water pump assembly
19	6A638	Crankcase oil cooler cover with oil cooler
20	6881	Oil filter adapter assembly
21	6L625	Engine oil filter and adapter assembly

22	6718	Oil filter outlet tube assembly
23	6714	Oil filter element
24	6C631	Oil filter cap
25	9F838	Injection control pressure (ICP) sensor
26	9E527	Fuel injector nozzle assembly
27	6095	Fuel pump cover

**6.0L Front Cylinder Head and Rocker Arm Carrier**

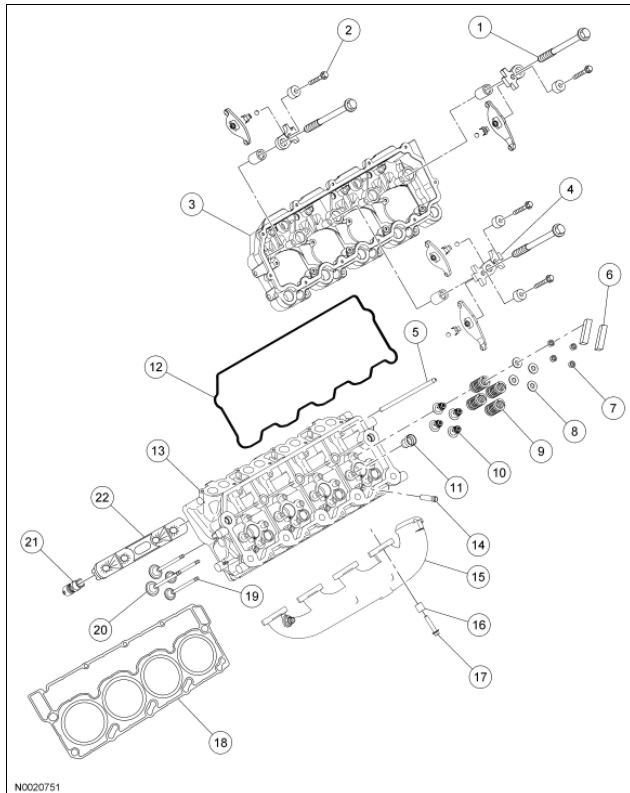

Item	Part Number	Description
1	6065	Cylinder head bolt
2	6A527	Valve rocker arm shaft support bolt
3	6C288	Engine rocker arm carrier
4	6A585	Valve rocker arm fulcrum assembly
5	6565	Valve push rod assembly
6	6C541	Valve rocker bridge
7	6518	Valve spring retainer key
8	6514	Valve spring retainer
9	6513	Valve spring
10	6571	Valve stem seal
11	9F538	Fuel injector nozzle sleeve
12	6584	Valve rocker arm cover gasket
13	6049	Cylinder head assembly
14	9F538	Fuel injector nozzle sleeve (glow plug)

15	9431	Exhaust manifold
16	9A461	Exhaust manifold-to-cylinder head spacer
17	W300013	Exhaust flange bolt
18	6051	Cylinder head gasket
19	6505	Exhaust valve
20	6507	Intake valve
21	6500	Valve tappet assembly
22	6C329	Crankcase cam guide

**6.0L Valve Cover**

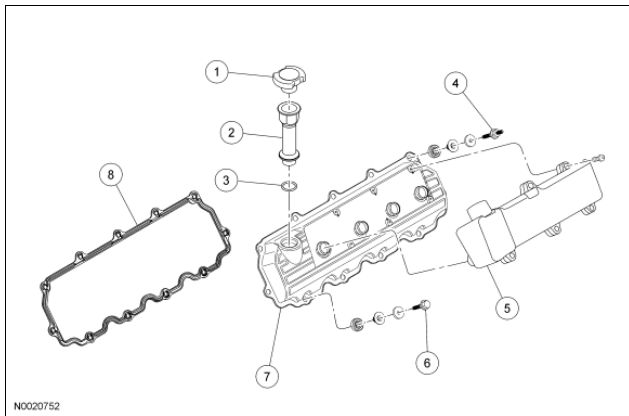

Item	Part Number	Description
1	6766	Oil fill cap assembly
2	6763	Oil fill extension assembly
3	6769	O-ring
4	W300035	Valve cover stud assembly
5	6A665	Crankcase breather
6	W300034	Valve cover bolt assembly
7	6A505	Valve cover assembly (LH)
8	6584	Rocker arm cover gasket

**Assembly**

**All vehicles**

1. **⚠ CAUTION:** Install new D-ring seals on the crankcase-to-head tube. It requires several hours after installation for the D-ring seals to relax back to their original size. If the tube assembly is installed before the D-ring seals have relaxed, damage to the D-ring seals can occur.

Install new D-ring seals on the crankcase-to-head tube assemblies.

