

DRIVE COMPONENTS

Description

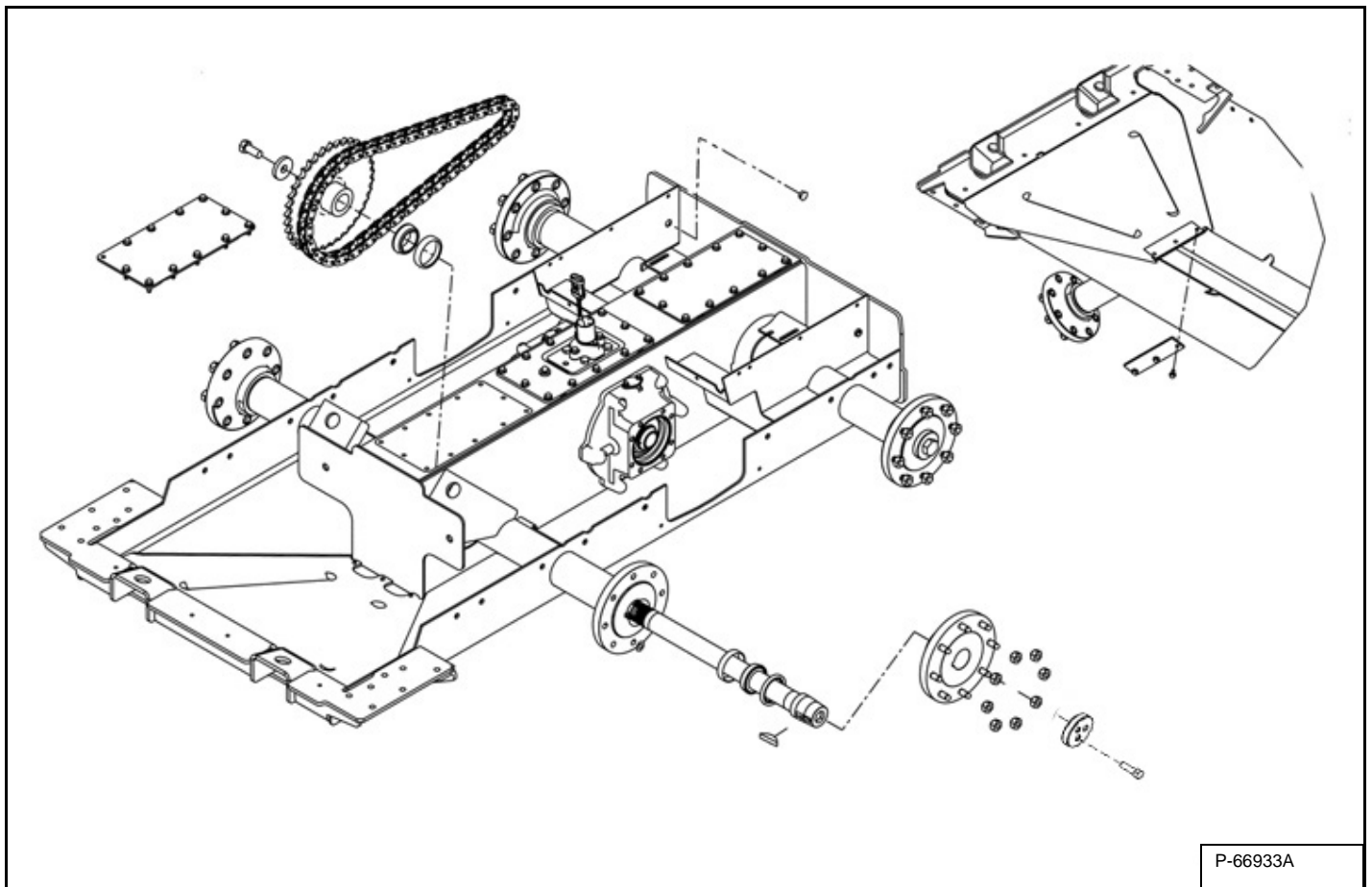

The drive components consist of the chaincase, drive chains, sprockets, axleshafts, hubs, drive motor carrier and a brake (Single speed only).

The two speed brake is part of the two speed drive motor.

The chaincase is partially filled with hydraulic fluid to lubricate the chains and bearings.

On the bottom of the chaincase, there is a cover for access to the fuel tank drain plug.

DRIVE COMPONENTS (CONT'D)

Axle Seal Removal And Installation

The tools listed are needed for the following procedure:

Axle Hub Puller Tool
MEL1407 - Seal Driver Tool
MEL1242 - Power Ram (may be used if desired)

Lift and block the loader. (See Procedure on Page 10-10-1.)

NOTE: If the axle and bearings are being replaced, also loosen the sprocket mounting bolt inside the chaincase before lifting and blocking the loader. (See Axle, Sprocket And Bearings Removal And Installation on Page 40-20-4.)

Remove the tire / wheel assembly. (See Mounting on Page 10-160-2.)

Remove the front chaincase cover. (See Front Cover Removal And Installation on Page 40-30-1.)

Remove the fluid from the chaincase. (See Removing And Replacing Oil on Page 10-130-1.)

Figure 40-20-1

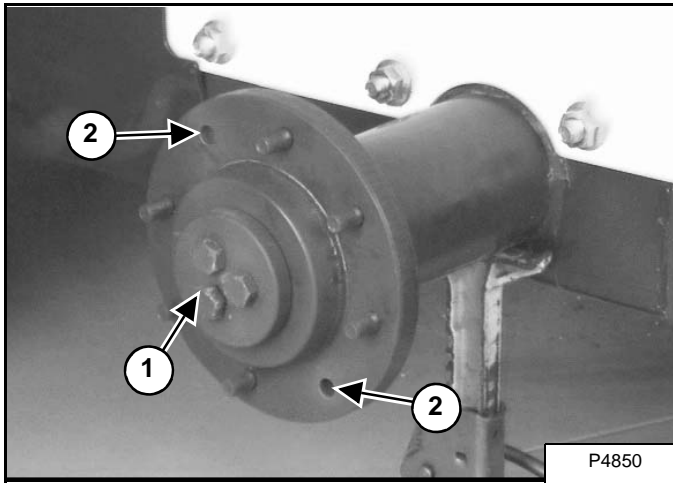

Remove the bolts (Item 1) [Figure 40-20-1] and plate.

Installation: Tighten the bolts to 175 - 190 ft.-lb. (240 - 260 N•m) torque.

Remove the two wheel studs (Item 2) [Figure 40-20-1] across from each other.

Figure 40-20-2

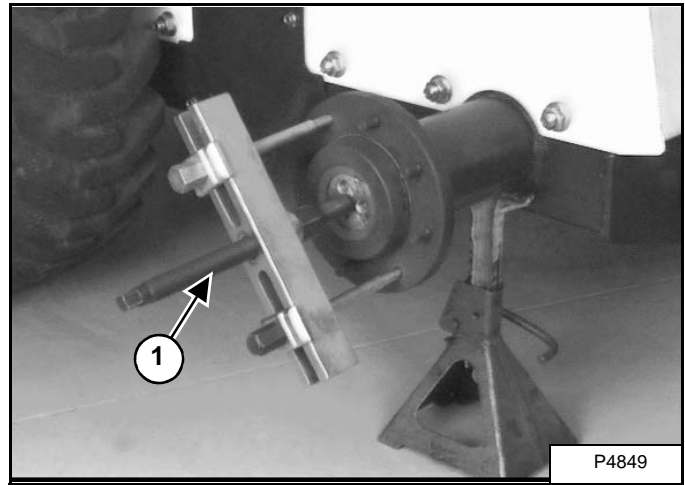

Install puller (Item 1) [Figure 40-20-2] on the wheel hub.

! WARNING

NEVER STAND IN-LINE OF THE HUB WHEN REMOVING A HUB FROM AN AXLE. The hub has a tapered fit on the axle end and can come off the axle with great force and cause serious injury.

W-2186-0395

Remove the hub from the axle.

Figure 40-20-3

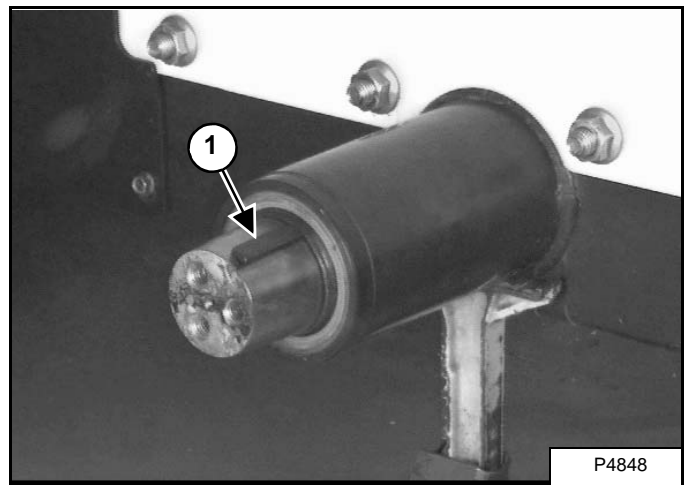

Remove the key (Item 1) [Figure 40-20-3] from the axle.

DRIVE COMPONENTS (CONT'D)

Axle Seal Removal And Installation (Cont'd)

Figure 40-20-4

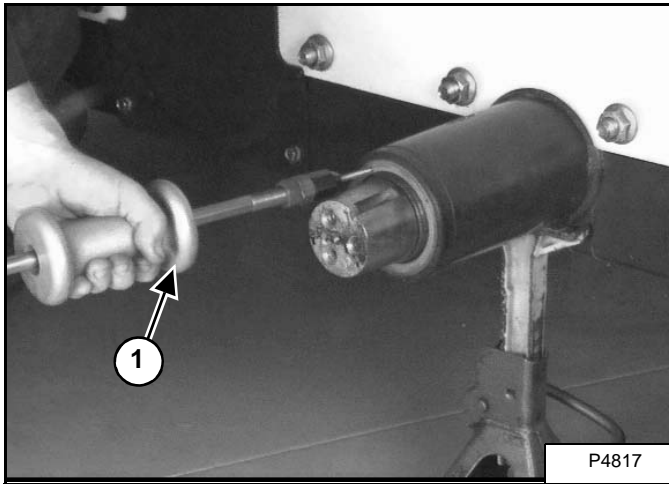

Install a slide hammer (Item 1) [Figure 40-20-4] with a screw tip end into the axle seal.

Remove the axle seal.

Figure 40-20-5

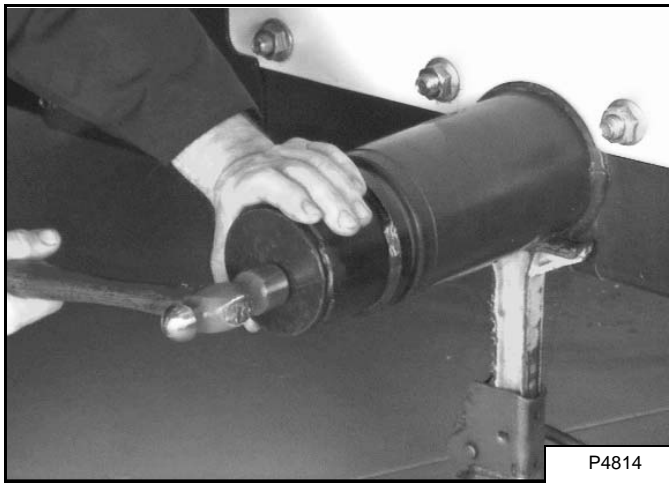

Installation: Place the seal with the lip facing in [Figure 40-20-5].

Installation: Use a hammer, install the new axle seal until the tool (MEL1407) is flush with the edge of the axle tube [Figure 40-20-5].

DRIVE COMPONENTS (CONT'D)

Axle, Sprocket And Bearings Removal And Installation

The tools listed will be needed to do the following procedure:

MEL1242 - Port-a-Power
MEL1202B - Axle Bearing Service Set

NOTE: The procedure shown for removal and installation of the axle, sprocket and bearings is for a front axle. This procedure will be the same for the rear axle.



P-90328

AVOID DEATH

- Disconnecting or loosening any hydraulic tubeline, hose, fitting, component or a part failure can cause lift arms to drop.
- Keep out of this area when lift arms are raised unless supported by an approved lift arm support. Replace if damaged.

D-1009-0409



Never work on a machine with the lift arms up unless the lift arms are secured by an approved lift arm support device. Failure to use an approved lift arm support device can allow the lift arms or attachment to fall and cause injury or death.

W-2059-0598

Raise the lift arms and install an approved lift arm support device. (See Installing on Page 10-20-1.)

Lift and block the loader. (See Procedure on Page 10-10-1.)

Raise the operator cab. (See Raising on Page 10-30-2.)

Remove the control panel. (See Removal And Installation on Page 50-100-2.)

Remove the front chaincase cover. (See Front Cover Removal And Installation on Page 40-30-1.)

Remove the fluid from the chaincase. (See Removing And Replacing Oil on Page 10-130-1.)

Figure 40-20-6

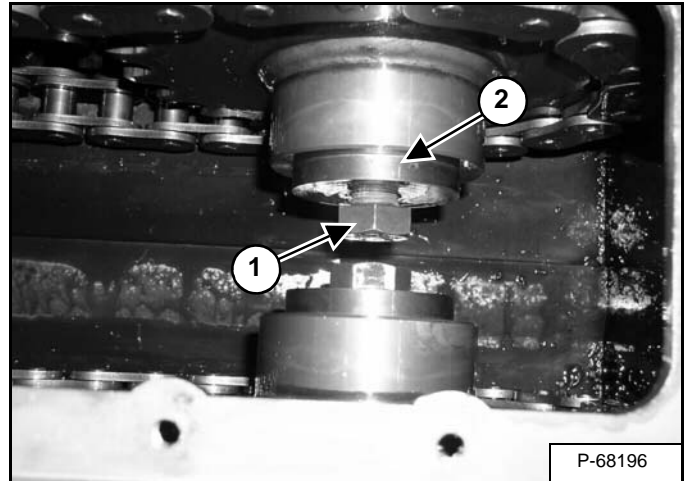

P-68196

Remove the axle sprocket bolt (Item 1) and backing washer (Item 2) [Figure 40-20-6].

Installation: Tighten the axle sprocket bolt to 515 - 535 ft.-lb. (699 - 726 N•m) torque.

Remove the axle hub. (See Axle Seal Removal And Installation on Page 40-20-2.)

Figure 40-20-7

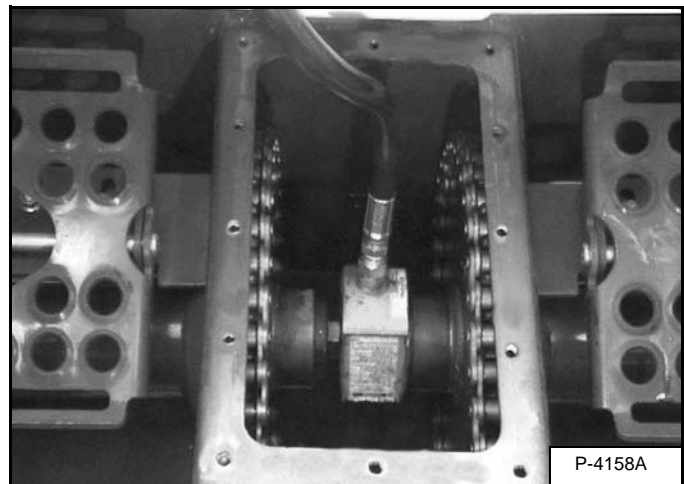

P-4158A

Install a Port-a-Power ram between the two sprockets [Figure 40-20-7].

DRIVE COMPONENTS (CONT'D)

Axle, Sprocket And Bearings Removal And Installation (Cont'd)

Figure 40-20-8

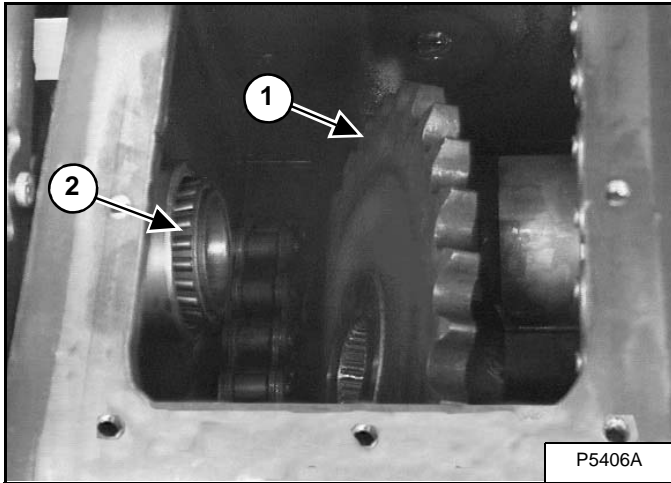

Push the axle out until the ram is at the end of the stroke. Add a spacer and push the axle out again. Repeat this procedure until the axle is out of the sprocket.

Remove the drive chain from the sprocket.

Remove the sprocket (Item 1) and inner bearing (Item 2) [Figure 40-20-8].

Installation: Pack the inner and outer bearing with grease before installing them.

Figure 40-20-9

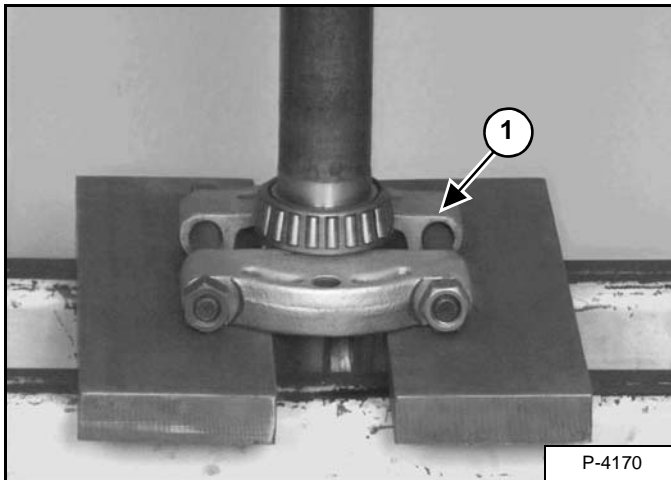

A bearing puller (Item 1) [Figure 40-20-9] is needed to do the following procedure:

Be sure the bearing puller makes good contact with the inner race and press the bearing off the mounting surface of the axle [Figure 40-20-9].

NOTE: Hold the axle during removal because it will slide freely after the bearing is removed from the mounting surface.

Figure 40-20-10

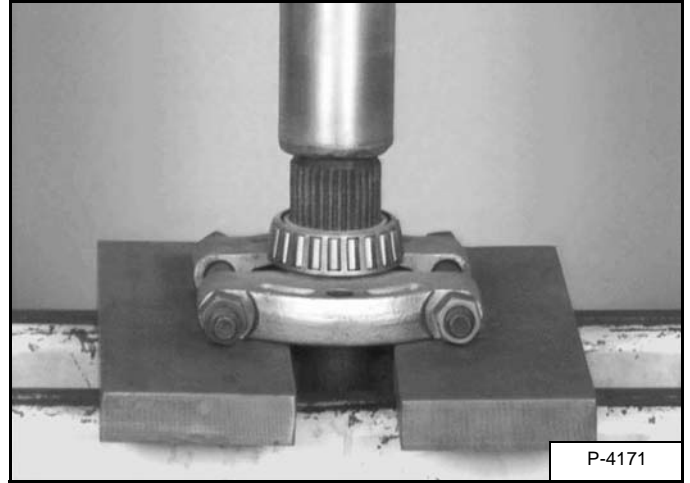

Press the splined end of the axle free from the bearing [Figure 40-20-10].

DRIVE COMPONENTS (CONT'D)

Axle, Sprocket And Bearings Removal And Installation (Cont'd)

Figure 40-20-11

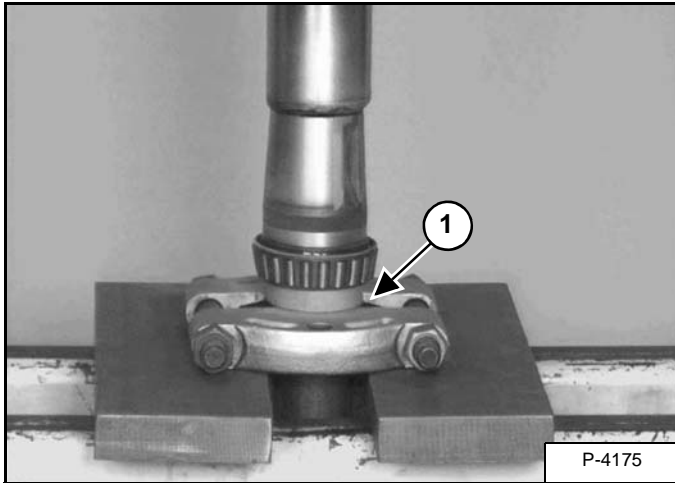

Installation: Put the spline end of the axle shaft into the bearing and press the bearing onto the axle.

NOTE: Hold the axle during installation because it will slide freely after the bearing is pressed over the splined end of the shaft.

Put a piece of tubing over the axle (Item 1) [Figure 40-20-11] that contacts inner race of the bearing only.

Press the bearing onto the mounting surface until the bearing is fully seated [Figure 40-20-11].

Figure 40-20-12

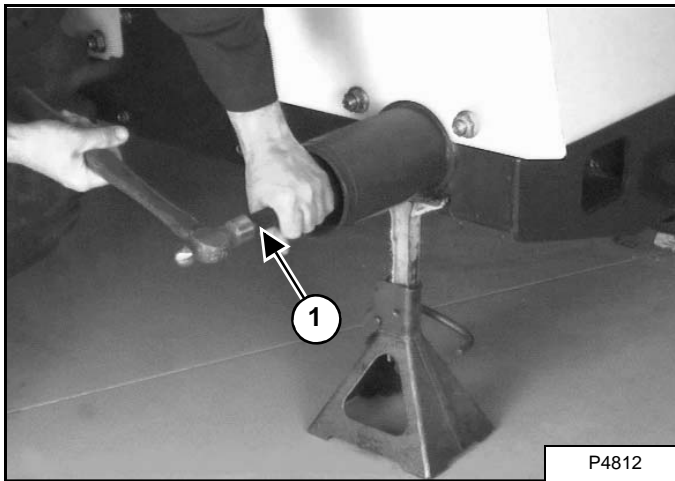

Use the tools provided in the MEL1202B Axle Bearing Service Set. A slide hammer is also needed.

Use the long driver handle (Item 1) [Figure 40-20-12] and the bearing cup removal tool to remove the inner bearing cup.

The bearing cup removal tool must fall into the recess behind the bearing cup, drive the cup out of the axle tube [Figure 40-20-13].

Figure 40-20-13

