

## HYDROSTATIC PUMP (SJC)

### Description

The SJC hydrostatic pump is a fully proportional dual piston pump in one pump casing. The endcaps are removable to gain access to the rotating assemblies.

The hydraulic controllers are fed charge pressure from an external charge pump. 12 volt electrical solenoids shift a spool in the hydraulic controller that directs flow to a servo piston.

The servo piston strokes the swash plate in the rotating group. The rotating group generates flow to the A or B ports on the hydrostatic pump. The flow from the A and B ports is sent to the hydrostatic drive motors where forward or reverse drive motor rotation is obtained.

There are swash plate angle sensors on the bottom of the pump that monitor swash plate movement.

Ports are labeled on the hydrostatic pump casting.

Figure 30-41-1

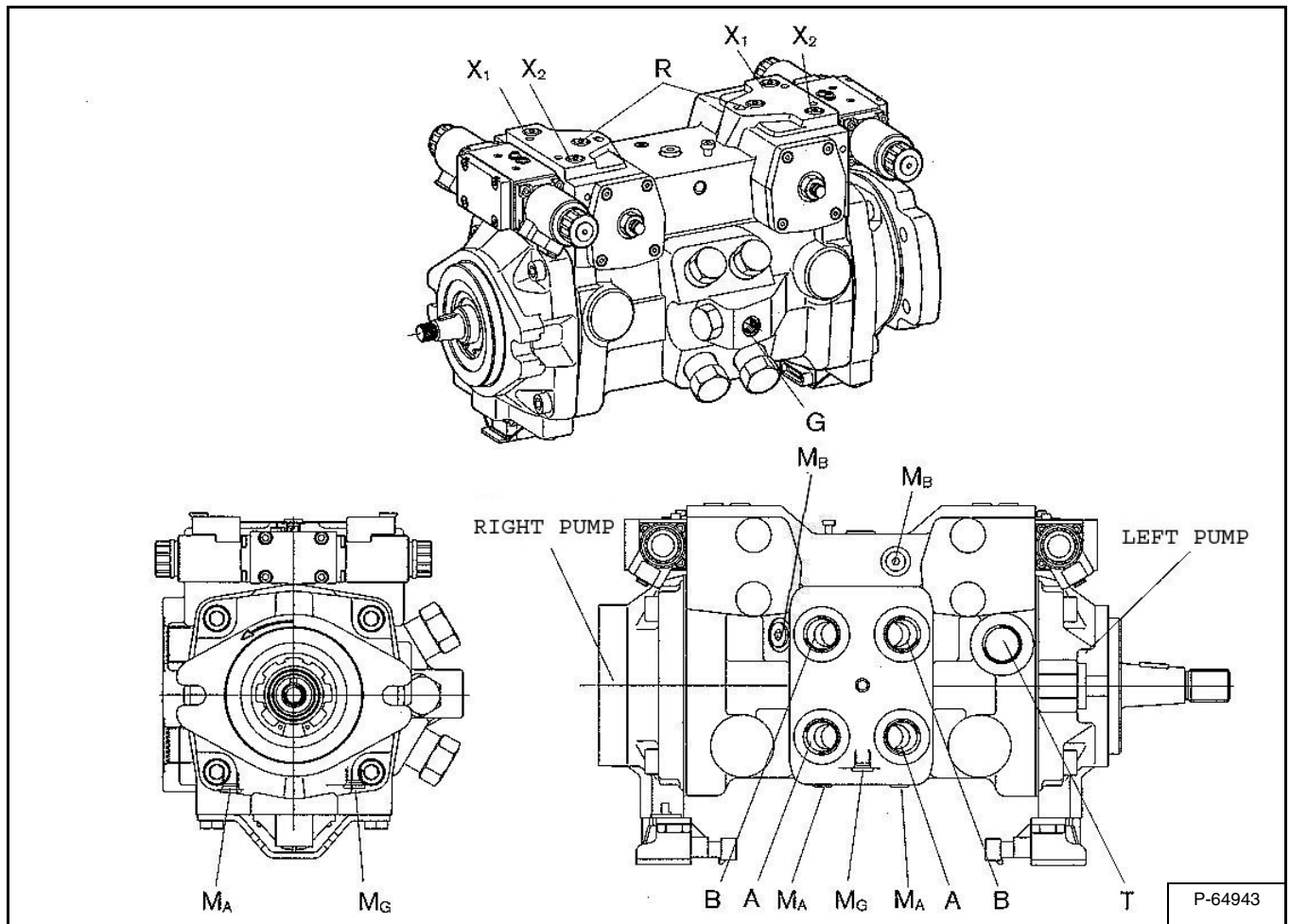

- A,B** Service Line Ports (High Pressure Outlet Ports to Drive Motors)
- T1** Case Drain Port
- MA** Operating Pressure of "A" Port
- MB** Operating Pressure of "B" Port
- R** Air Bleed Port
- X1,X2** Control Pressure Gauge Port
- G** Charge Pressure Inlet Port
- MG** Gauge Port For Charge Pressure

## HYDROSTATIC PUMP (SJC) (CONT'D)

### Hydraulic Controller Removal And Installation

The loader's right hand side hydraulic controller can be removed with the hydrostatic pump still in the loader. The loader's left hand side hydraulic controller can only be removed when the hydrostatic pump is separated from the engine/hydrostatic pump cast mount.

Controller solenoids can be bled of trapped air in the controller. This should be performed when hydraulic controllers are replaced, removed or uncommanded oscillations in the controls are present.

Raise the lift arms and install an approved lift arm support device. (See Installing on Page 10-20-1.)

Place the loader on jack stands. (See Procedure on Page 10-10-1.)



Put jackstands under the front axles and rear corners of the frame before running the engine for service. Failure to use jackstands can allow the machine to fall or move and cause injury or death.

W-2017-0286

Raise the operator cab. (See Raising on Page 10-30-2.)

Figure 30-41-2

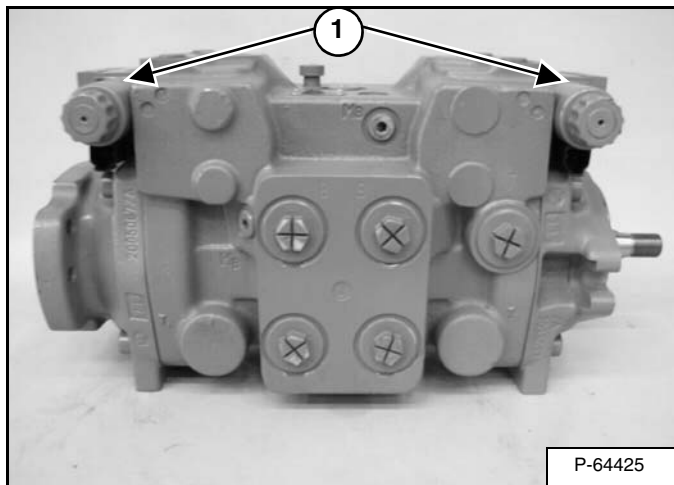

Locate the two hydraulic controllers (Item 1) [Figure 30-41-2] on the hydrostatic pumps.

Figure 30-41-3

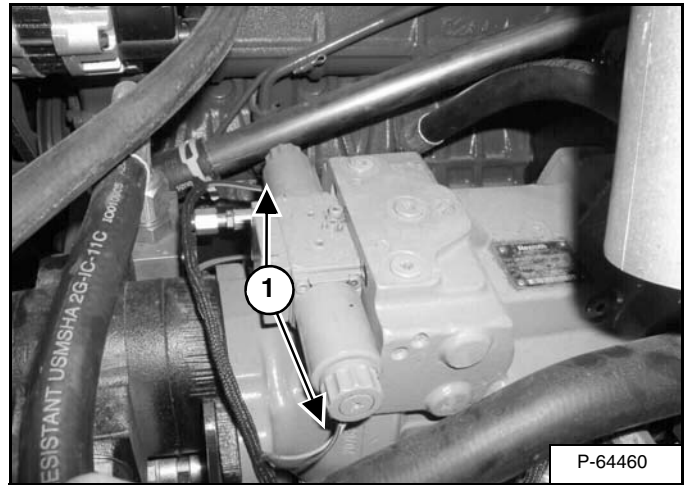

Disconnect all of the electrical harness connectors (Item 1) [Figure 30-41-3] from the loader harness.

### Removal:



When repairing hydrostatic and hydraulic systems, clean the work area before disassembly and keep all parts clean. Always use caps and plugs on hoses, tubelines and ports to keep dirt out. Dirt can quickly damage the system.

I-2003-0888

Figure 30-41-4

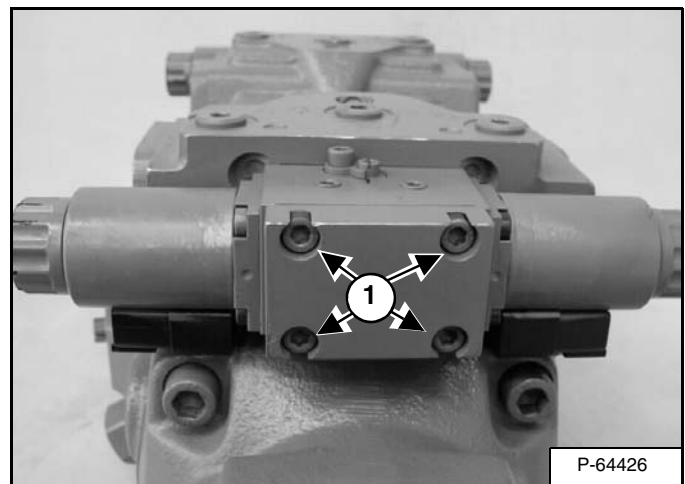

Remove the four mount bolts (Item 1) [Figure 30-41-4] from the hydraulic controller.

## HYDROSTATIC PUMP (SJC) (CONT'D)

### Hydraulic Controller Removal And Installation (Cont'd)

Figure 30-41-5

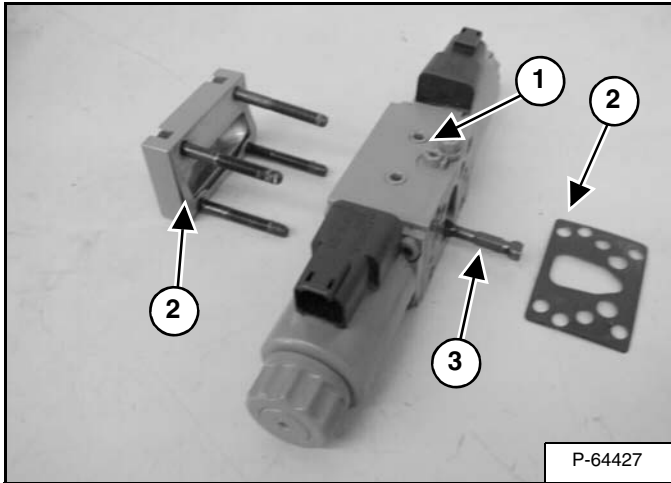

Remove the controller (Item 1) [Figure 30-41-5] from the pump.

Remove the controller gaskets (Item 2) [Figure 30-41-5] from the pump.

#### **Installation:**

Figure 30-41-6

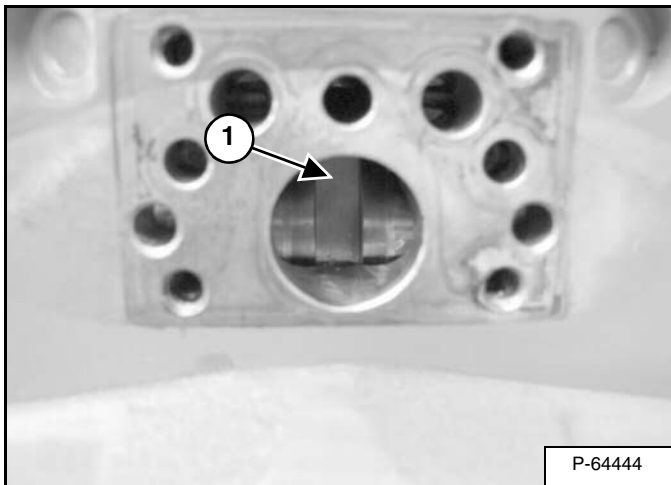

Be sure the feedback lever (Item 3) [Figure 30-41-5] is in the center of the servo piston groove (Item 1) [Figure 30-41-6].

Use a small amount of grease on a new gasket and install the gasket on the hydraulic controller (Item 1) [Figure 30-41-5].

Be sure the pump surface is clean.

Figure 30-41-7

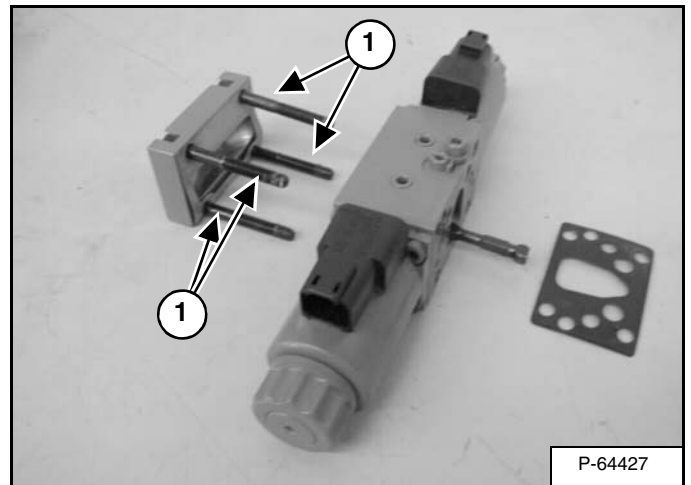

Alternately tighten bolts (Item 1) [Figure 30-41-7] to 7.7 ft.-lb. (10,4 N•m) torque. Ensure bolts are tight to specifications.

**NOTE: When a hydraulic controller is replaced, the hydrostatic pumps must be calibrated. (See Hydraulic Controller Neutral Adjustment on Page 30-41-29.)**

Figure 30-41-8

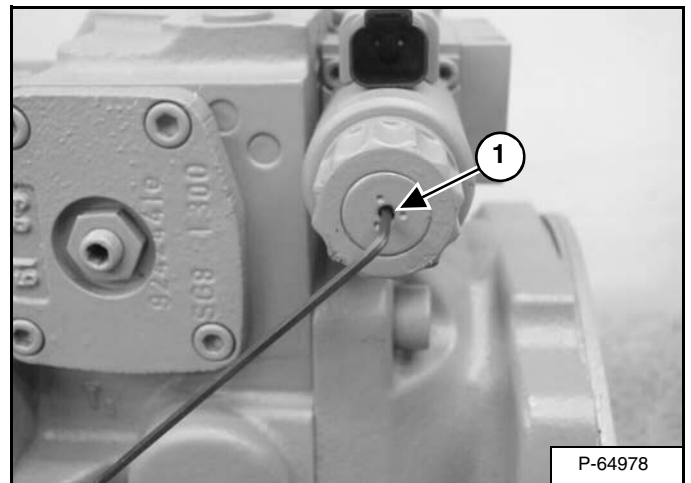

With the engine running and the loader on jack stands: Bleed the trapped air in the controller by loosening the small set screw (Item 1) [Figure 30-41-8] a maximum of 2 turns. Leave the screw loose until oil comes dripping out of the set screw. Tighten set screw to 18 in.-lb. (2 N•m) torque.

Repeat the bleeding procedure for all of the solenoids.

## HYDROSTATIC PUMP (SJC) (CONT'D)

### Removal And Installation

Remove the hydrostatic pump/engine assembly from the loader. (See Removal And Installation on Page 70-10-8.)

# IMPORTANT

When repairing hydrostatic and hydraulic systems, clean the work area before disassembly and keep all parts clean. Always use caps and plugs on hoses, tubelines and ports to keep dirt out. Dirt can quickly damage the system.

I-2003-0888

Figure 30-41-9

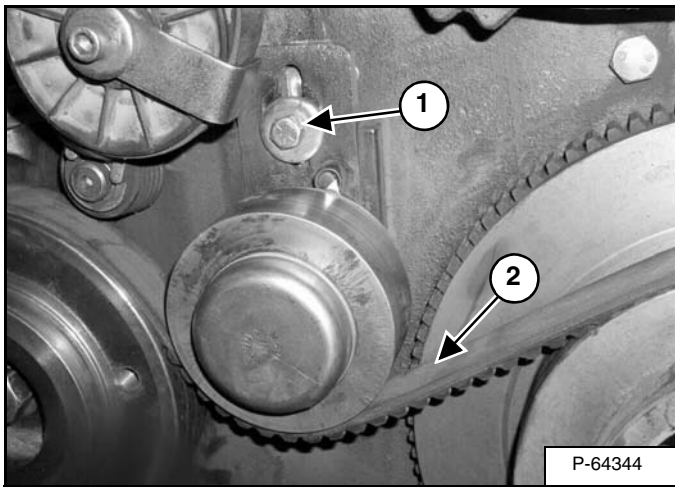

Loosen the tensioner mount bolt (Item 1) [Figure 30-41-9].

Remove the drive belt (Item 2) [Figure 30-41-9].

**Installation:** (See Belt Removal And Installation on Page 30-50-3.)

Figure 30-41-10

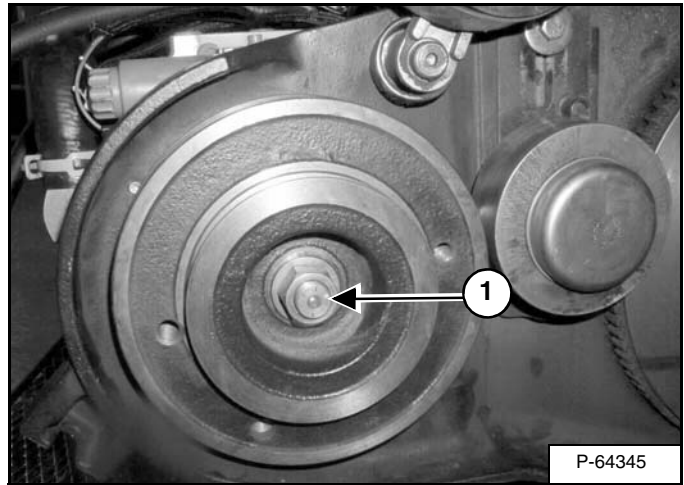

Loosen the washer and nut (Item 1) [Figure 30-41-10] on the hydrostatic pump drive shaft.

**Installation:** Tighten the nut to 175 - 200 ft.-lb. (237 - 271 N•m) torque

Figure 30-41-11

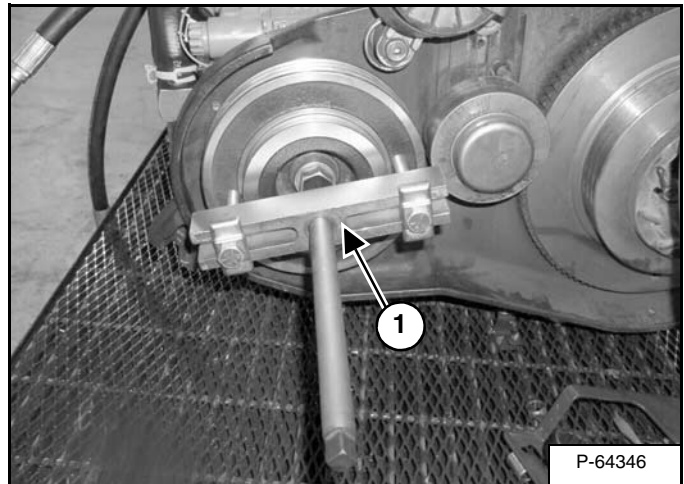

Use a puller (Item 1) [Figure 30-41-11] to loosen the pulley from the pump drive shaft.

**NOTE: DO NOT strike puller or pump shaft with a hammer. Internal pump damage may result.**

Remove the nut and washer from the pump drive shaft.

Remove the pump pulley from the pump drive shaft.

## HYDROSTATIC PUMP (SJC) (CONT'D)

### Removal And Installation (Cont'd)

Figure 30-41-12

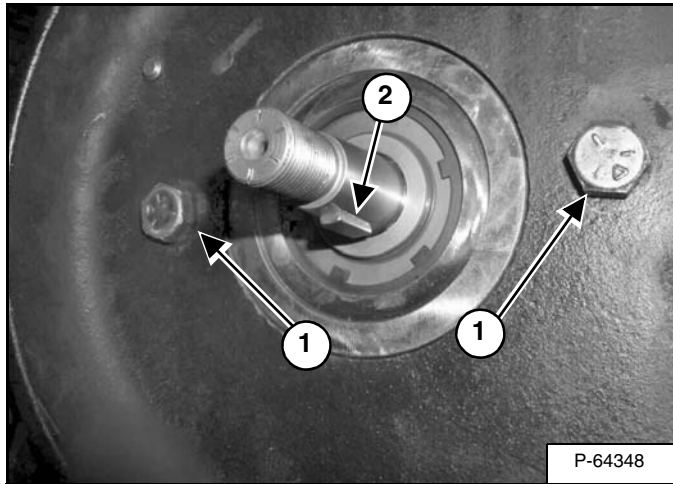
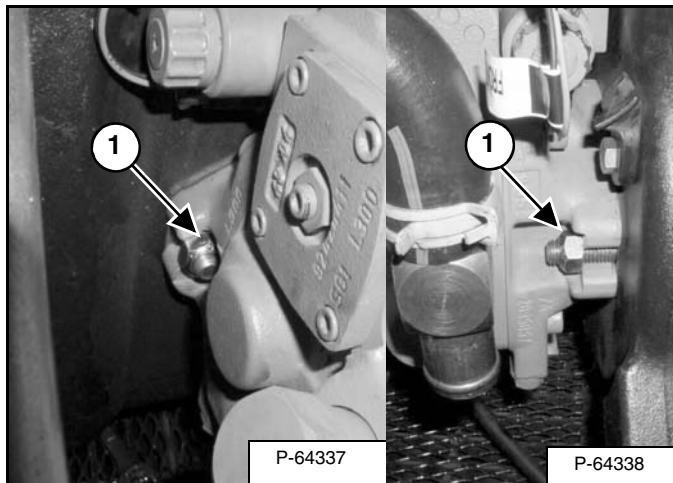

Figure 30-41-13



Remove the two mounting bolts (Item 1) [Figure 30-41-12] and nuts (Item 1) [Figure 30-41-13].

**Installation:** Tighten the mounting bolts and nuts to 65 - 70 ft.-lb. (88 - 95 N•m) torque.

Make sure the key (Item 2) [Figure 30-41-12] is installed.

Figure 30-41-14

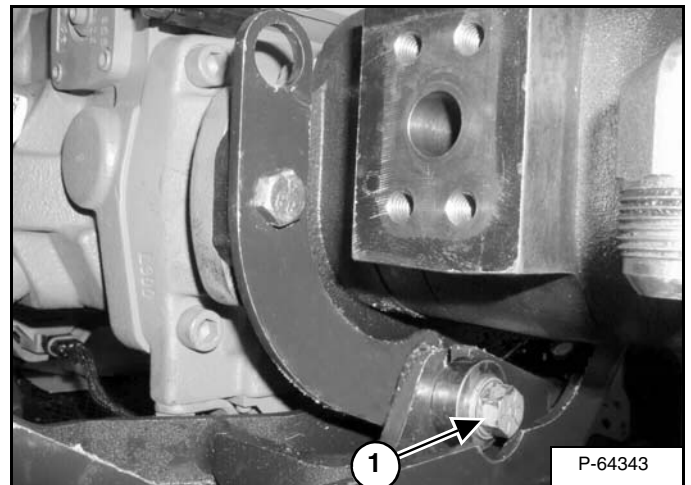

Remove the mounting bolt (Item 1) [Figure 30-41-14] at the hydraulic pump mounting bracket.

**Installation:** Tighten mounting bolt to 90 - 100 ft.-lb. (125 - 135 N•m)

**NOTE: The mounting bolt is a special purpose bolt. Only replace with original Bobcat Parts.**

Remove the hydrostatic pump from the mounting bracket and drive belt housing.

**BEFORE START UP:** Fill the hydrostatic pump with hydraulic oil. This will remove trapped air in the hydrostatic pumps before start up. (See Hydrostatic Pump Startup on Page 30-41-6.)