

HYDROSTATIC PUMP (SJC AND SCPA) (CONT'D)

Mechanical Neutral Adjustment (Cont'd)

Figure 30-50-70

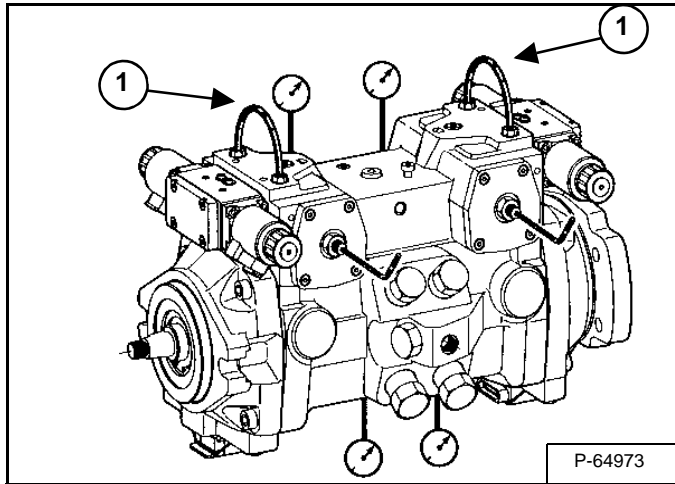

Connect a hydraulic hose (Item 1) [Figure 30-50-70] between port X1 and port X2 on each side of the hydrostatic pump, to equalize the pressures on both ends of the servo pistons.

Figure 30-50-71

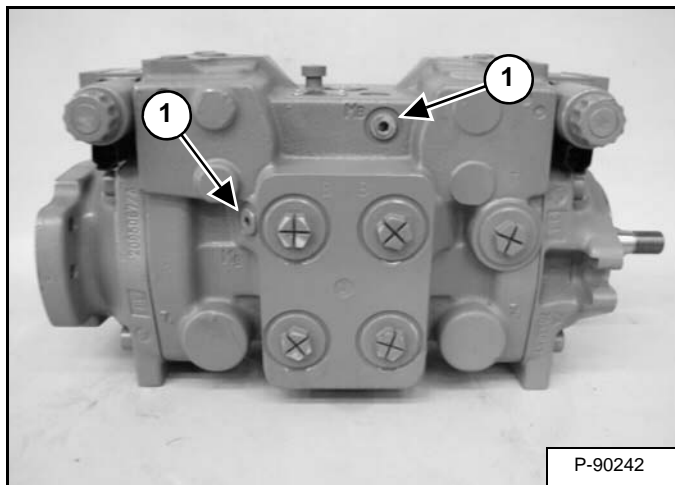

Remove the plugs (Item 1) [Figure 30-50-71] from the MB ports on the front side of the pump, and install 51710,7 kPa (517 bar) (7500 psi) pressure gauges.

Figure 30-50-72

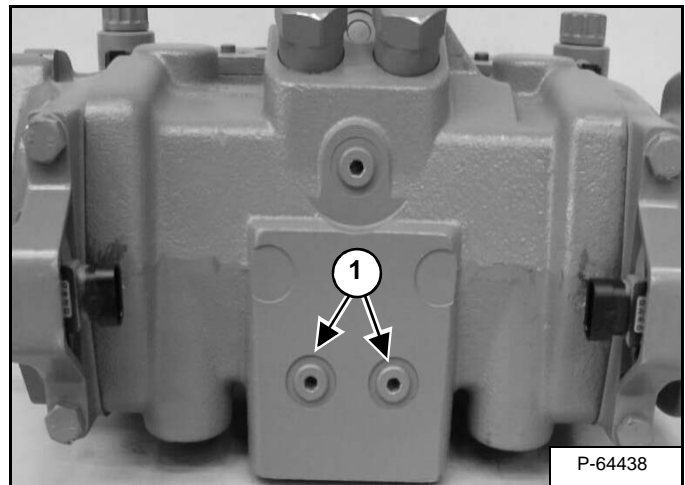

Remove the plugs (Item 1) [Figure 30-50-72] from the MA ports on the bottom of the pump, and install 51710,7 kPa (517 bar) (7500 psi) pressure gauges.

Figure 30-50-73

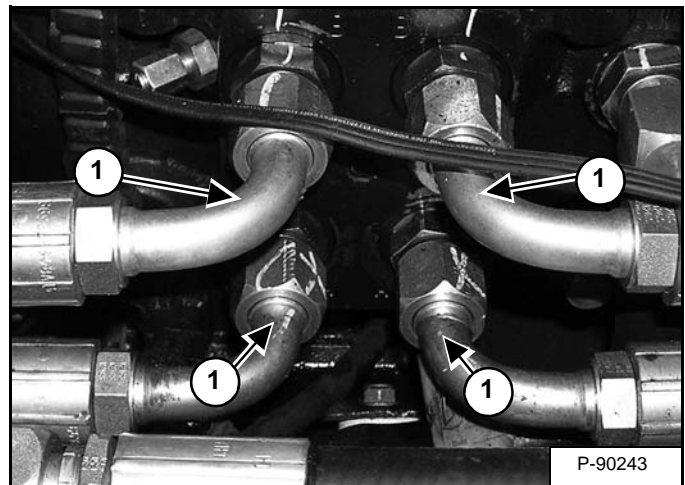

Remove drive hoses from the A and B ports (Item 1) [Figure 30-50-73]. Plug the ports with metal caps. The caps must be able to handle at least 51710,7 kPa (517 bar) (7500 psi). Plugging the A and B ports eliminates leakage at the drive motors from causing errors in the pump mechanical neutral setting.

HYDROSTATIC PUMP (SJC AND SCPA) (CONT'D)

Mechanical Neutral Adjustment (Cont'd)

Figure 30-50-74

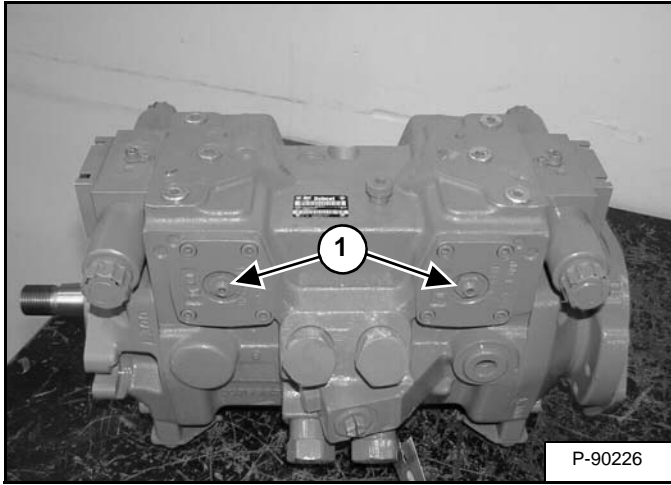

Loosen the pump neutral adjustment lock nut (Item 1) [Figure 30-50-74].

Start the loader using the remote start tool and run at idle.

WARNING

Stay clear of the loader wheels. They will turn whenever the pump is not centered.

W-2276-1297

Figure 30-50-75

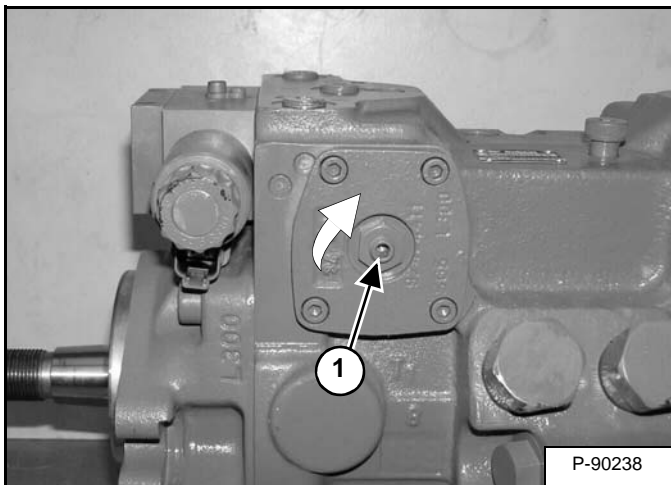

Turn the adjustment screw (Item 1) [Figure 30-50-75] clockwise, until one of the gauges registers an increase in system pressure. Mark the position of the adjustment screw.

Figure 30-50-76

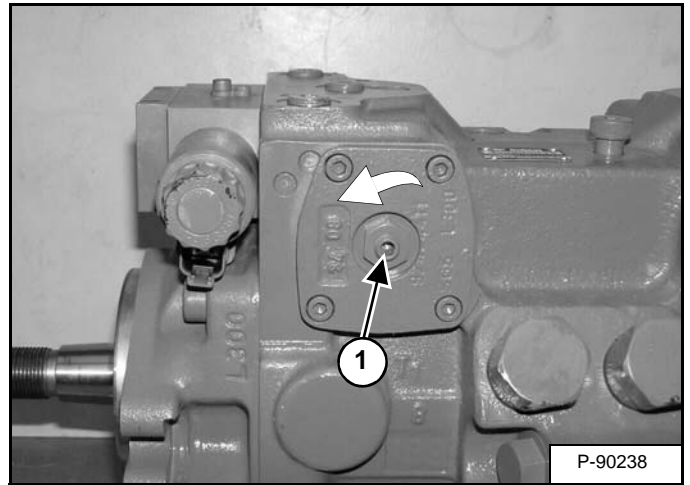

Turn the adjustment screw (Item 1) [Figure 30-50-76] counterclockwise, until the other gauge registers an increase in system pressure. Mark the position of the adjustment screw.

Figure 30-50-77

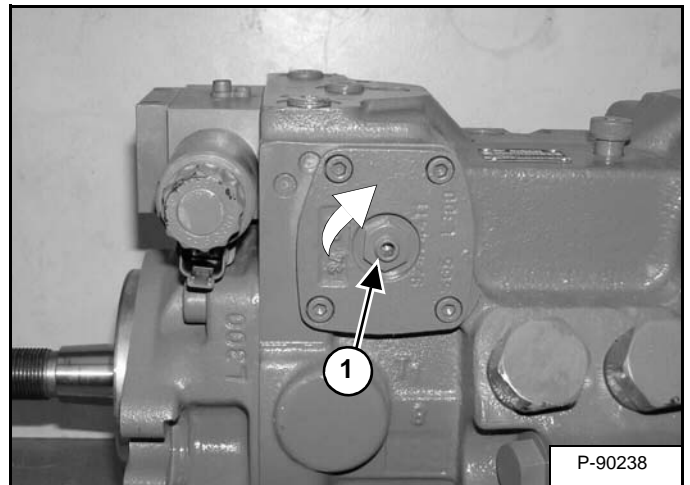

Turn the adjustment screw (Item 1) [Figure 30-50-77] clockwise, to a position halfway between the recorded positions. The pressure gauges should read equal pressures.

HYDROSTATIC PUMP (SJC AND SCPA) (CONT'D)

Mechanical Neutral Adjustment (Cont'd)

Figure 30-50-78

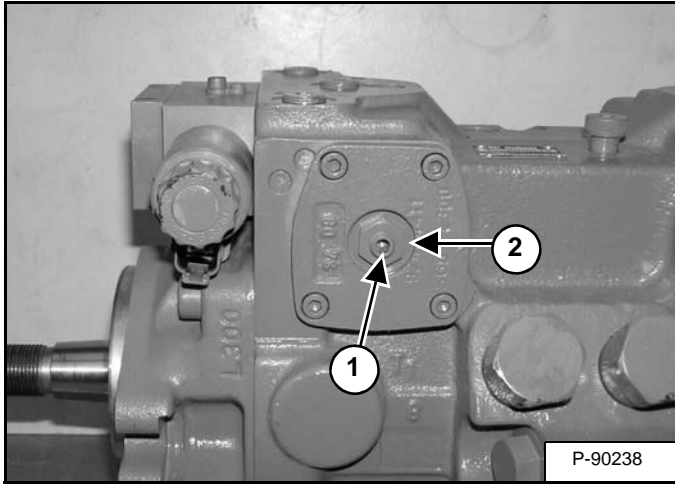

While holding the adjustment screw (Item 1) in position, tighten the lock nut (Item 2) [Figure 30-50-78] to 30 N•m (22 ft-lb) torque.

Shut loader OFF.

Remove the hydraulic hose from the X1 and X2 ports on the pump. Install the plugs and tighten to 25 N•m (18 ft-lb) torque.

Remove the pressure gauges from the MA and MB ports on the pump. Install the plugs and tighten to 25 N•m (18 ft-lb) torque.

NOTE: The Hydraulic Controller Neutral Adjustment must be performed whenever the Mechanical Neutral Adjustment is done. (See Hydraulic Controller Neutral Adjustment on Page 30-51-26.)

Hydraulic Controller Neutral Adjustment

The hydraulic controller neutral adjustment, aligns the pump swash plate and the control spool so that a zero angle control setting provides a zero degree swash plate setting. This adjustment should be performed whenever any part of the control or swash plate mechanisms are adjusted or removed or after the pump mechanical neutral setting is adjusted. Ensure the pump mechanical neutral setting is correct before performing hydraulic controller neutral adjustments.

NOTE: Procedure is shown for the left side hydraulic controller. Procedure is the same for the right side hydraulic controller, except you disconnect the electrical connectors for the right side hydraulic controller and connect pressure gauges in the X1 and X2 ports on the right side of the pump.

Place the loader on jackstands. (See Procedure on Page 10-10-1.)

WARNING

Put jackstands under the front axles and rear corners of the frame before running the engine for service. Failure to use jackstands can allow the machine to fall or move and cause injury or death.

W-2017-0286

Raise the lift arms, and install an approved lift arm support device. (See Installing on Page 10-20-1.)

Raise the operator cab. (See Raising on Page 10-30-2.)

Connect the remote start tool. (See REMOTE START TOOL KIT-MEL1563 on Page 10-60-1.) or (See REMOTE START TOOL (SERVICE TOOL) KIT - 7003031 on Page 10-61-1.)

WARNING

Hydraulic fluid escaping under pressure can have sufficient force to enter a person's body by penetrating the skin. This can cause serious injury and possible death if proper medical treatment by a physician familiar with this injury is not received immediately.

W-2145-0290

HYDROSTATIC PUMP (SJC AND SCPA) (CONT'D)

Hydraulic Controller Neutral Adjustment (Cont'd)

Figure 30-50-79

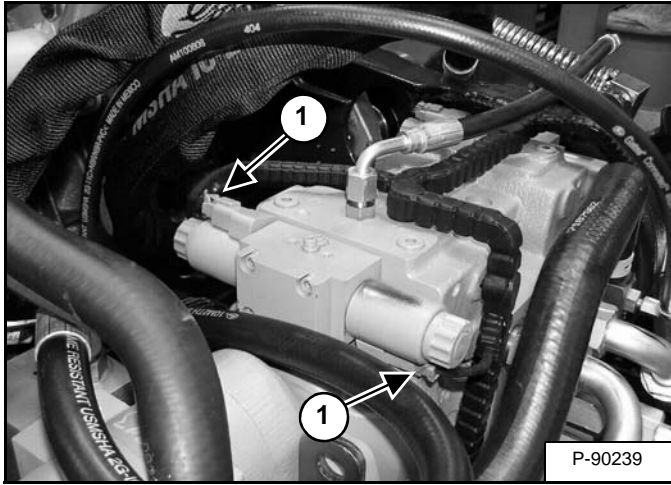

Disconnect the hydraulic controller connectors (Item 1) [Figure 30-50-79] from the loader wiring harness for the hydraulic controller you are adjusting.

Figure 30-50-80

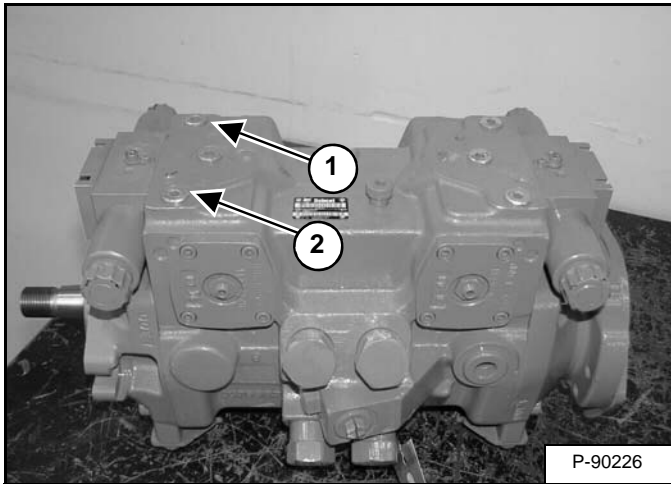

Remove the X1 plug (Item 1) and X2 plug (Item 2) [Figure 30-50-80] pertaining to the side of the hydrostatic pump you are adjusting.

Figure 30-50-81

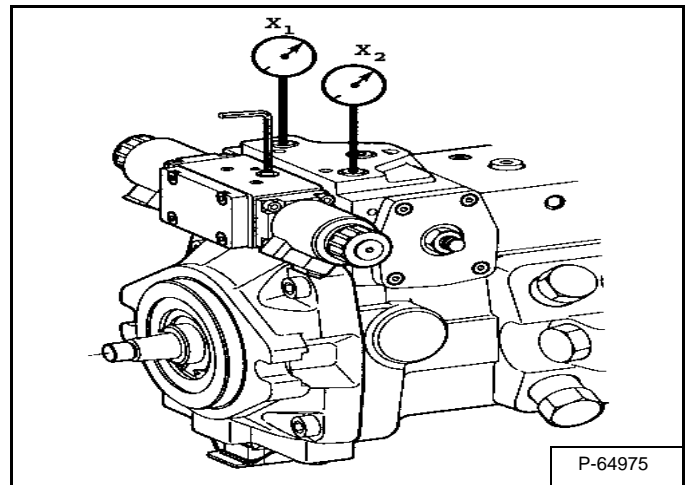

Install 3447,4 kPa (34,5 bar) (500 psi) pressure gauges in the X1 and X2 ports pertaining to the side of the hydrostatic pump you are adjusting.

Figure 30-50-82

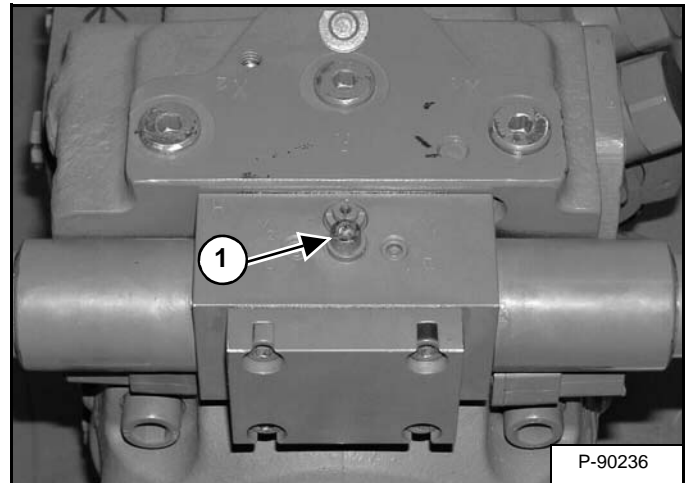

Loosen the locking screw (Item 1) [Figure 30-50-82].

Start the loader using the remote start tool and run at an idle.

WARNING

Stay clear of the loader wheels. They will turn whenever the pump is not centered.

W-2276-1297