

3.5. Electrical System

3.5.1. Electrical parts

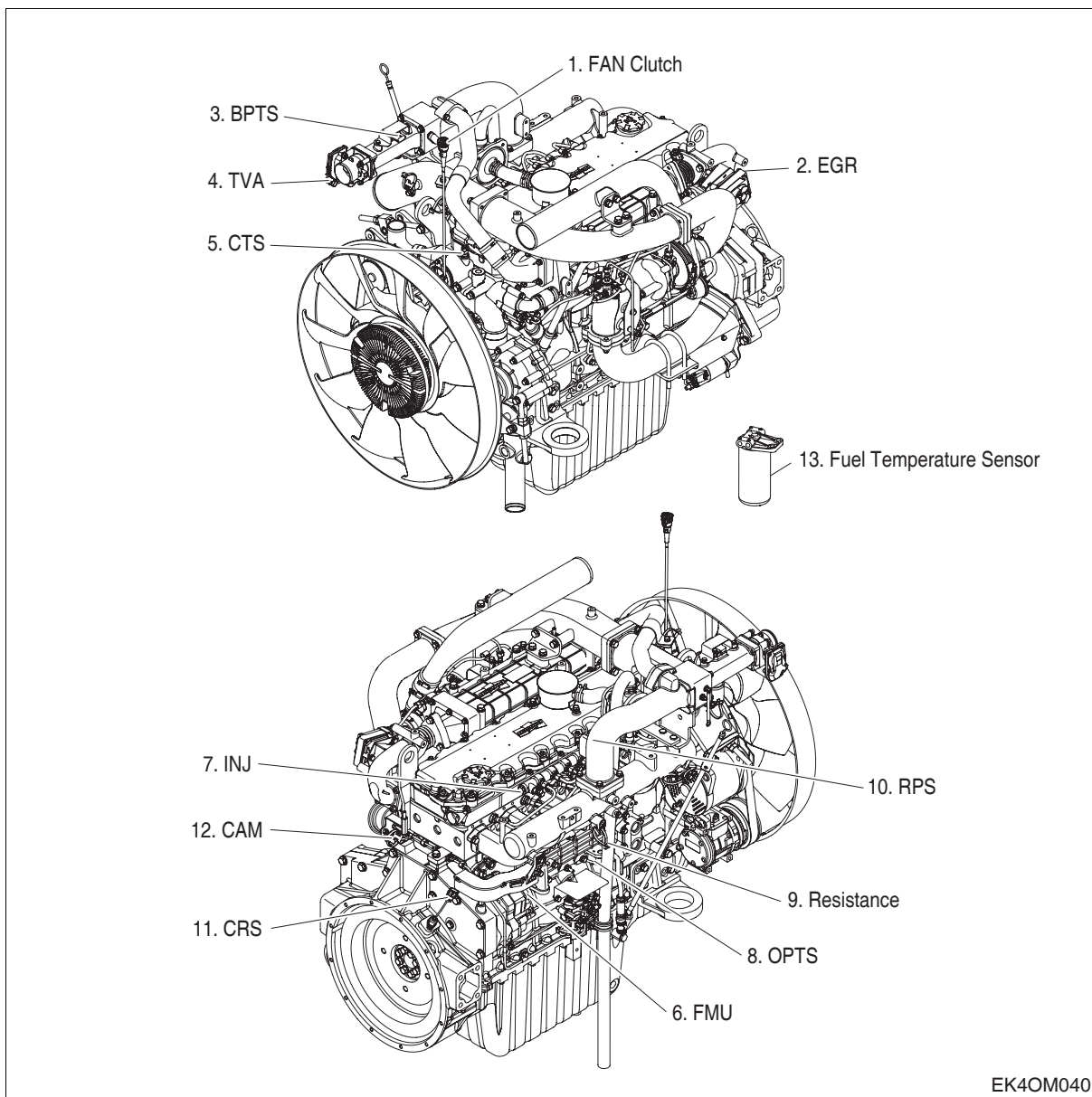

- | | |
|--|---|
| 1. Fan clutch sensor (FAN Clutch) | 8. Oil pressure temperature sensor (OPTS) |
| 2. Exhaust gas recirculation actuator sensor (EGR) | 9. Resistance connector (Resistance) |
| 3. Boost pressure temperature sensor (BPTS) | 10. Commonrail pressure sensor (RPS) |
| 4. Throttle valve actuator/position sensor (TVA) | 11. Crankshaft speed sensor (CRS) |
| 5. Cooling water temperature sensor (CTS) | 12. Camshaft speed sensor (CAM) |
| 6. Fuel pressure sensor (FMU) | 13. Fuel temperature sensor (FTS) |
| 7. Injector sensor (INJ) | |

3.5.2. Harness of electric control unit

1) Vehicle connector

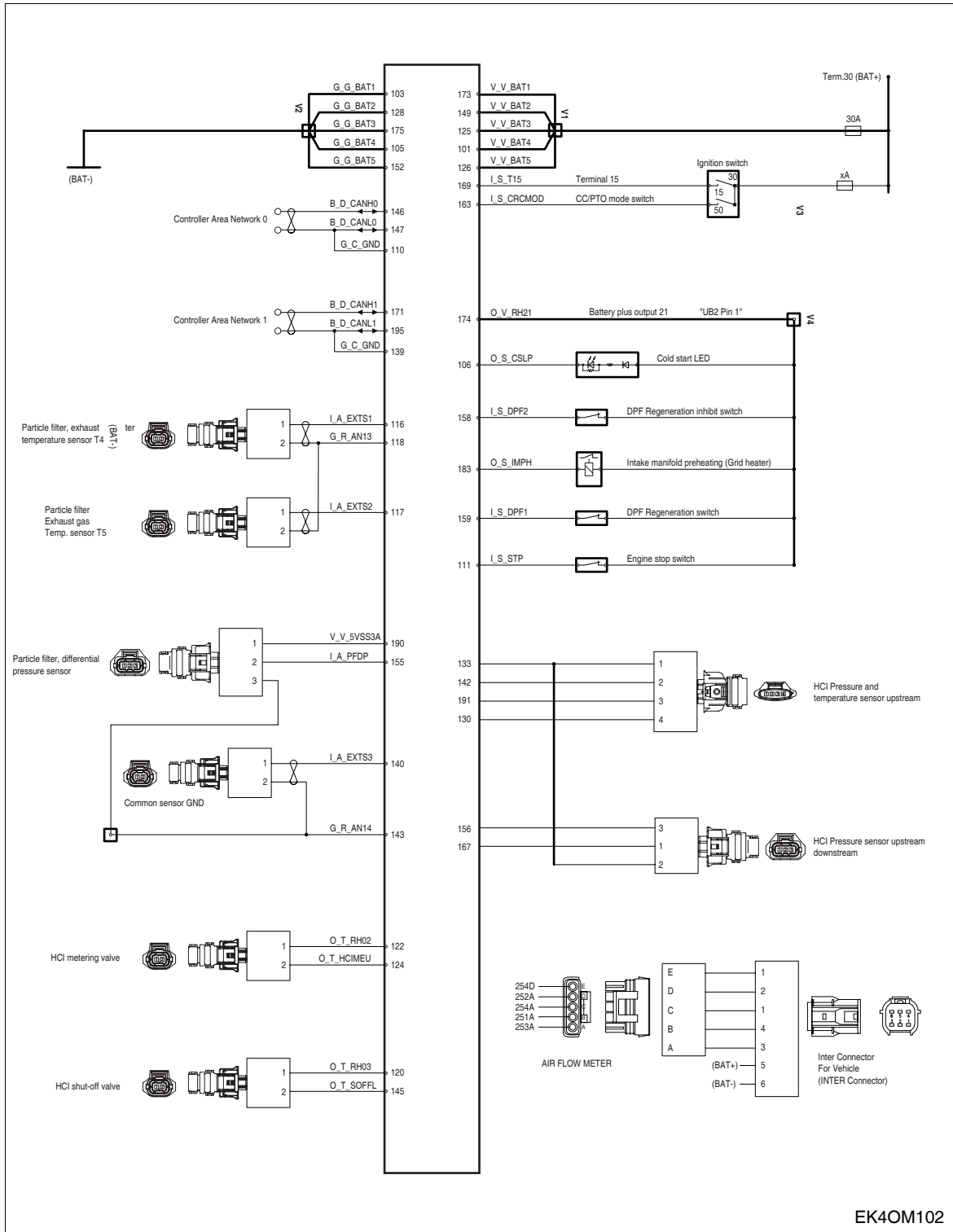

EK4OM102

2) Engine connector

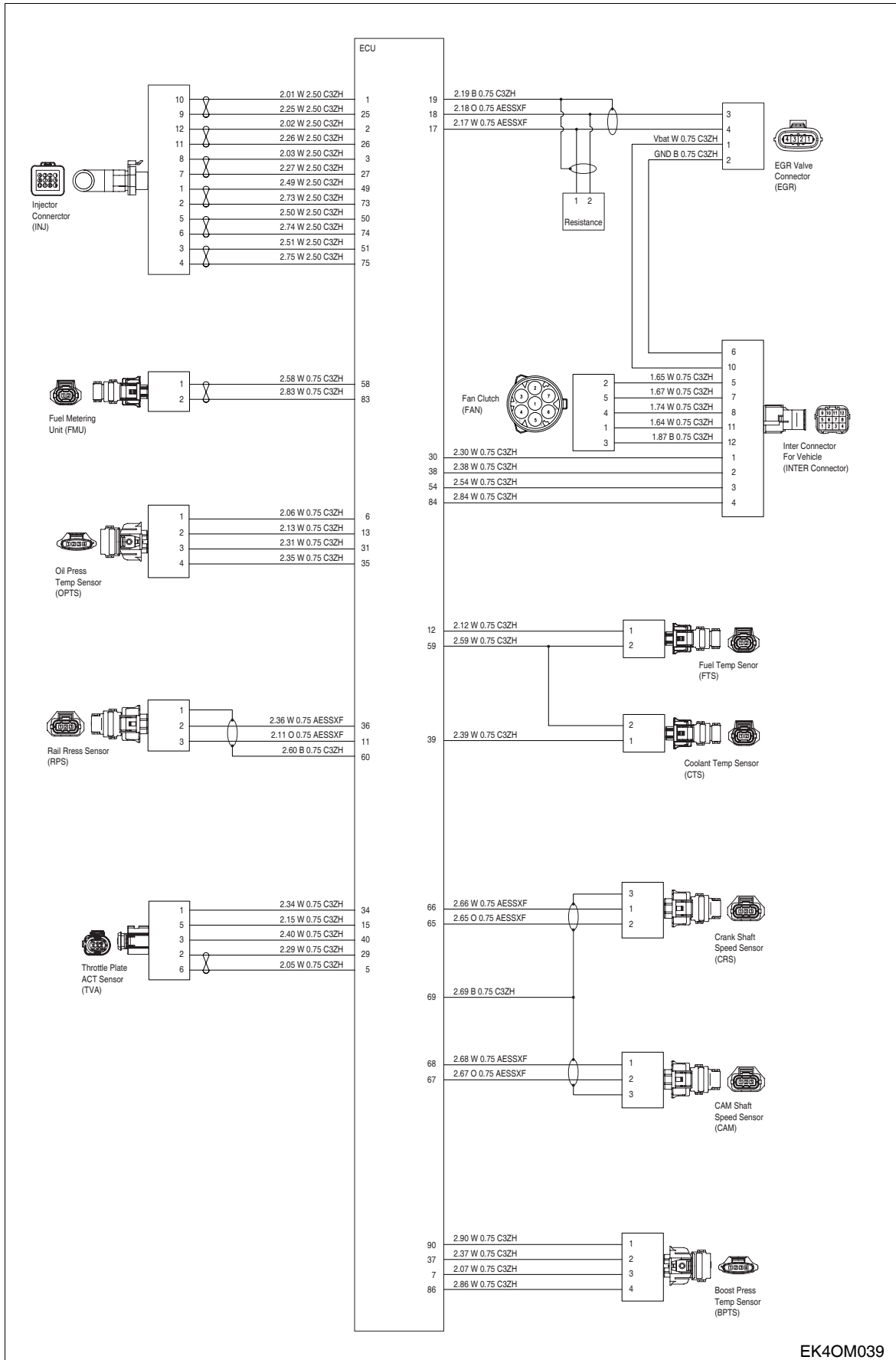

EK40M039