

Vehicle Identification

GROUP

1

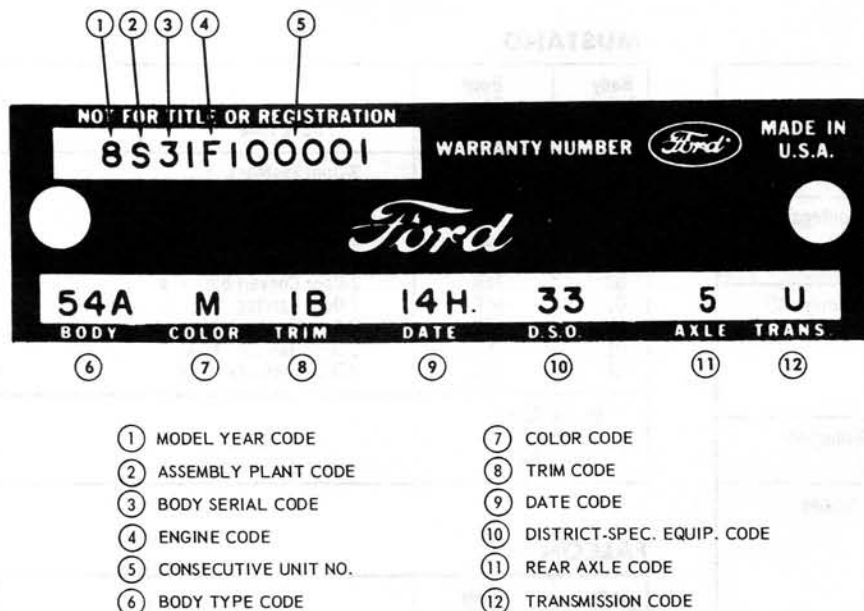

N 1672-A

FIG. 1—Typical Warranty Plate — Fairlane Shown



N 1673-A

FIG. 2—Typical Vehicle Identification Number (VIN) Tab—Fairlane Shown

VEHICLE WARRANTY NUMBER

The vehicle warranty number is the first line of numbers and letters appearing on the Warranty Plate (Fig. 1). The Warranty Plate is riveted to the left front door lock face panel. The first number indicates the model year. The letter following the model year number indicates the manufacturing assembly plant. The next two numbers designate the Body Serial Code followed by a letter expressing the Engine Code. The group of six digits remaining on the first line indicate the Consecutive Unit Number.

VEHICLE DATA

The vehicle data appears on the second or lower line on the Warranty Plate. The first two numbers and a letter identify the Body Style. A letter or a number appears next indicating the Exterior Paint Color followed by a number-letter combination designating the Interior Trim. To the right of this code ap-

pears the Date Code indicating the date the vehicle was manufactured. A two-digit number next designates the district in which the car was ordered and may appear in conjunction with a Domestic Special Order or Foreign Special Order number when applicable. The final two spaces indicate the Rear Axle Ratio (numbers for regular axles, letters for locking-types) and the Transmission type (numbers for manual, letters for automatic).

OFFICIAL VEHICLE IDENTIFICATION NUMBER

The official Vehicle Identification Number (VIN) for title and registration purposes will be stamped on an aluminum tab that will be riveted to the instrument panel close to the windshield on the passenger side of the vehicle and will be visible from outside (Fig. 2).

MODEL YEAR CODE

The number 8 designates 1968.

BODY SERIAL AND STYLE CODES

The two-digit numeral which follows the assembly plant code identifies the body series. This two-digit number is used in conjunction with the Body Style Code, in the Vehicle Date, which consists of a two-digit number with a letter suffix. The following charts list the Body Serial Codes, Body Style Codes and the models.

MONTEGO

Body Serial Code	Body Style Code	Body Type	Model
01	65A	Sports Coupe ¹⁾	Comet
02 06 07	54A 54B 65B	Sports Sedan ¹⁾ 4-Door Sedan ¹⁾ 2-Door Hardtop ¹⁾ ³⁾	Montego
10 11 12 11 12	54D 65D 76D 65E 76B	4-Door Sedan ¹⁾ 2-Door Hardtop ¹⁾ ³⁾ 2-Door Convertible ¹⁾ 2-Door Hardtop ²⁾ ³⁾ 2-Door Convertible ²⁾	Montego MX
10 11	54C 65C	4-Door Sedan 2-Door Hardtop ³⁾	Brougham
15 17 15 17 15 17	63A 65F 63C 65G 63H 65H	2-Door Hardtop ¹⁾ 2-Door Hardtop ¹⁾ ³⁾ 2-Door Hardtop ²⁾ 2-Door Hardtop ²⁾ ³⁾ 2-Door Hardtop GT ²⁾ 2-Door Hardtop GT ²⁾ ³⁾	Cyclone
03 08	71B 71C	4-Door Wagon ¹⁾ 4-Door Wagon ¹⁾	Montego MX

¹⁾ Bench Seat
²⁾ Bucket Seat
³⁾ Formal Roof

FAIRLANE

Body Serial Code	Body Style Code	Body Type	Model
31 30	54A 65A	4-Door Sedan ¹⁾ 2-Door Hardtop ¹⁾ ³⁾	Fairlane
34 33 35 36 35 33 36	54B 65B 63B 76B 63E 65E 76E	4-Door Sedan ¹⁾ 2-Door Hardtop ¹⁾ ³⁾ 2-Door Hardtop ¹⁾ 2-Door Convertible ¹⁾ ³⁾ 2-Door Hardtop ²⁾ 2-Door Hardtop ²⁾ ³⁾ 2-Door Convertible ²⁾	Fairlane 500
40 41	65C 54C	2-Door Hardtop ¹⁾ ³⁾ 4-Door Sedan ¹⁾	Torino
42 44 43	63D 65D 76D	2-Door Hardtop ²⁾ 2-Door Hardtop ²⁾ ³⁾ 2-Door Convertible ²⁾	Torino GT
32 37 38	71D 71B 71E	4-Door Wagon ¹⁾ 4-Door Wagon ¹⁾ 4-Door Wagon ³⁾	Fairlane Fairlane 500 Torina Squire
47 48 48 49	66A 66B 66B 66D	2-Door ¹⁾ 2-Door ¹⁾ 2-Door ²⁾ 2-Door ²⁾	Ranchero

¹⁾ Bench Seat ²⁾ Bucket Seat ³⁾ Formal Roof

COUGAR

Body Serial Code	Body Style Code	Body Type
91 91 91	65A 65B 65C	2-Door Hardtop (Bucket Seat) 2-Door Hardtop (Bucket Seat) 2-Door Hardtop (Bench Seat)

¹⁾ Luxury Model

MUSTANG

Body Serial Code	Body Style Code	Body Type
02 01 03 02 01 03 01 02 01 02	63A 65A 76A 63B 65B 76B 65C 63C 65D 63D	2-Door Fastback ¹⁾ 2-Door Hardtop ¹⁾ 2-Door Convertible ¹⁾ 2-Door Fastback ¹⁾ ²⁾ 2-Door Hardtop ¹⁾ ³⁾ 2-Door Convertible ¹⁾ ³⁾ 2-Door Hardtop ²⁾ 2-Door Fastback ²⁾ 2-Door Hardtop ²⁾ ³⁾ 2-Door Fastback ²⁾ ³⁾

¹⁾ Bucket Seat
²⁾ Bench Seat
³⁾ Luxury Model

FALCON

Body Serial Code	Body Style Code	Body Type	Model
10 11	62A 54A	2-Door Club Coupe ¹⁾ 4-Door Sedan ¹⁾	Standard
20 21	62B 54B	2-Door Club Coupe ¹⁾ 4-Door Sedan ¹⁾	Futura
22	62C	2-Door Sports Coupe ²⁾	
12	71A	4-Door	Wagon (Std.)
23	71B	4-Door	Wagon (Deluxe)

¹⁾ Bench Seat
²⁾ Bucket Seat

CONSECUTIVE UNIT NUMBER

Each model year, each assembly plant begins production with number 500001 (Montego or Cougar) or 100001 (Fairlane, Falcon, Mustang) and continues on for each unit built.

ENGINE CODES

Code	Type
U	6 Cyl. 170 Cu. In. (1V)
T	6 Cyl. 200 Cu. In. (1V)
Z	6 Cyl. 200 Cu. In. (1V)
C	8 Cyl. 289 Cu. In. (2V)
F	8 Cyl. 302 Cu. In. (2V)
6	8 Cyl. 302 Cu. In. (2V)
J	8 Cyl. 302 Cu. In. (4V)
Y	8 Cyl. 390 Cu. In. (2V)
X	8 Cyl. 390 Cu. In. (2V) Prem. Fuel
S	8 Cyl. 390 Cu. In. (4V) GT
W	8 Cyl. 427 Cu. In. (4V) Hi-Perf.

¹⁾ Low Compression

TRANSMISSION CODES

Code	Type
1	3-Speed Manual
5	4-Speed Manual
W	Automatic (C-4)
U	Automatic (C-6)

REAR AXLE RATIO CODES

A number designates a conventional axle, while a letter designates a locking differential.

Code	Ratio	Code	Ratio
1	2.75:1		
2	2.79:1		
4	2.83:1		
5	3.00:1	E	3.00:1
6	3.20:1	F	3.20:1
7	3.25:1	G	3.25:1
8	3.50:1	H	3.50:1
9	3.10:1		

DATE CODES

A number signifying the date precedes the month code letter. A second-year code letter will be used if the model exceeds 12 months.

Month	Code First Year	Code Second Year
January	A	N
February	B	P
March	C	Q
April	D	R
May	E	S
June	F	T
July	G	U
August	H	V
September	J	W
October	K	X
November	L	Y
December	M	Z

ASSEMBLY PLANT CODES

Code Letter	Code Letter
A	L
B	N
C	P
D	R
E	S
F	T
G	U
H	W
J	X
K	Y
	Z

DISTRICT CODES (DSO)

Units built on a Domestic Special Order, Foreign Special Order, or other special orders will have the complete order number in this space. Also to appear in this space is the two-digit code number of the District which ordered the unit. If the unit is a regular production unit, only the District code number will appear.

FORD

Code	District
11	Boston
13	New York
15	Newark
16	Philadelphia
17	Washington
21	Atlanta
22	Charlotte
24	Jacksonville
25	Richmond
27	Cincinnati
28	Louisville
32	Cleveland
33	Detroit
34	Indianapolis
35	Lansing
37	Buffalo
38	Pittsburgh
41	Chicago
42	Fargo
43	Milwaukee
44	Twin Cities
45	Davenport
51	Denver
52	Des Moines
53	Kansas City
54	Omaha
55	St. Louis
61	Dallas
62	Houston
63	Memphis
64	New Orleans
65	Oklahoma City
71	Los Angeles
72	San Jose
73	Salt Lake City
74	Seattle
75	Phoenix
81	Ford of Canada
83	Government
84	Home Office Reserve
85	American Red Cross
89	Transportation Services
90-99	Export

MERCURY

Code	District	Code	District
11	Boston	34	Detroit
15	New York	41	Chicago
16	Philadelphia	42	St. Louis
17	Washington	46	Twin Cities
21	Atlanta	51	Denver
22	Dallas	52	Los Angeles
23	Jacksonville	53	Oakland
26	Memphis	54	Seattle
31	Buffalo	84	Home Office Reserve
32	Cincinnati		
33	Cleveland	90	Export

FORD OF CANADA

Code	District	Code	District
B1	Central	B4	Midwestern
B2	Eastern	B6	Western
B3	Atlantic	B7	Pacific
I1 thru I7	Export		

Note: Lincoln-Mercury units will use suffix "A" in place of "B".

EXTERIOR PAINT COLOR CODES

CODE	M-30-J M-32-J	Color
A	1724-A	Black
B	3059-A	Maroon
D	3077-A	Bright Blue Met.
F	3065-A	Bright Aqua Met.
I	2041-A	Lime Green Met.
M	1619-A	White
N	921-A	Diamond Blue
O	2040-A	Light Green
Q	1624-A	Med. Blue Met.
R	3067-A	Dk. Green Met.
T	2008-A	Red
U	1070-A	Med. Aqua Met.
W	3120-A	Yellow
X	3061-A	Dark Blue Met.
Y	3073-A	Gold Met.
3	1730-A	Vermillion
5	1724-G	Low Gloss Black
6	1631-A	Lt. Beige

INTERIOR TRIM CODES

Code	Trim Scheme
1A	Black Cloth and Black Vinyl
1B	Med. Blue Cloth and Lt. Blue Vinyl
1G	Med. Ivy Gold Cloth and Lt. Ivy Gold Vinyl
1K	Lt. Aqua Vinyl
1U	Lt. Parchment Cloth and Pastel Parchment Vinyl
1Y	Lt. Nugget Gold Vinyl
2A	Black Vinyl
2B	Dk. & Lt. Blue Vinyl
2D	Red Vinyl
2F	Med. Saddle Vinyl
2G	Lt. Ivy Gold Vinyl
2K	Lt. Aqua Vinyl
2U	Pastel Parchment Vinyl
2Y	Lt. Nugget Gold Vinyl
3A	Black Vinyl (Montego)
3A	Black Cloth and Black Vinyl (Fairlane)
3B	Lt. Blue Vinyl (Montego)
3B	Med. Blue Cloth and Lt. Blue Vinyl (Falcon, Fairlane)
3D	Dk. Red Vinyl
3G	Med. Ivy Gold Cloth and Lt. Ivy Gold Vinyl
3K	Med. Aqua Cloth and Lt. Aqua Vinyl
3U	Pastel Parchment Vinyl (Montego)
3U	Lt. Parchment Cloth and Pastel Parchment Vinyl (Falcon)
3Y	Lt. Nugget Cloth and Lt. Nugget Vinyl
4A	Black Vinyl
4B	Lt. Blue Vinyl
4D	Dk. Red Vinyl
4G	Lt. Ivy Gold Vinyl
4K	Lt. Aqua Vinyl
4U	Pastel Parchment Vinyl
4Y	Lt. Nugget Gold Vinyl
5A	Black Cloth and Black Vinyl (Montego)
5A	Black Vinyl (Fairlane)
5B	Med. Blue Cloth and Lt. Blue Vinyl (Montego)
5B	Dk. & Lt. Blue Vinyl (Fairlane)
5D	Dk. Red Cloth and Dk. Red Vinyl (Montego)
5D	Dk. Red Vinyl (Fairlane)
5G	Lt. Ivy Gold Cloth and Lt. Ivy Gold Vinyl
5K	Med. Aqua Cloth and Lt. Aqua Vinyl (Montego)
5K	Dk. & Lt. Aqua Vinyl (Fairlane)
5U	Lt. Parchment Cloth and Pastel Parchment Vinyl (Montego)
5U	Pastel Parchment Vinyl (Fairlane)
5Y	Lt. Nugget Gold Cloth and Lt. Nugget Gold Vinyl (Montego)
5Y	Lt. Nugget Gold Vinyl (Fairlane)
6A	Black Vinyl
6B	Dk. & Lt. Blue Vinyl
6D	Dk. Red Vinyl
6F	Med. Saddle Vinyl
6G	Med. & Lt. Ivy Gold Vinyl
6K	Dk. & Lt. Aqua Vinyl
6U	Pastel Parchment Vinyl
6Y	Lt. Nugget Gold Vinyl
7A	Black Vinyl (Cougar)
7A	Black Cloth and Black Vinyl (Fairlane, Montego)

INTERIOR TRIM CODES—(continued)

Code	Trim Scheme
7B	Lt. Blue Vinyl (Cougar)
7B	Med. Blue Cloth and Lt. Blue Vinyl (Fairlane)
7B	Dk. Blue Cloth and Dk. Blue Vinyl (Montego)
7D	Dk. Red Cloth and Dk. Red Vinyl
7G	Med. Ivy Gold Cloth and Lt. Ivy Gold Vinyl
7K	Med. Aqua Cloth and Lt. Aqua Vinyl
7Y	Nugget Gold Cloth and Nugget Gold Vinyl
8A	Black Vinyl
8B	Dk. Blue Vinyl
8D	Dk. Red Vinyl
8F	Med. Saddle Vinyl with Black
8G	Med. & Lt. Ivy Gold Vinyl
8K	Dk. & Lt. Aqua Vinyl
8U	Pastel Parchment Vinyl
8Y	Nugget Gold Vinyl
9A	Black Vinyl
9B	Dk. Blue Vinyl
9D	Dk. Red Vinyl
9U	Parchment Vinyl
9Y	Lt. Nugget Gold Vinyl
AA	Pastel Parchment Vinyl with Black
AB	Pastel Parchment Vinyl with Blue
AD	Pastel Parchment Vinyl with Red
AF	Pastel Parchment Vinyl with Saddle
AG	Pastel Parchment Vinyl with Ivy Gold
AK	Pastel Parchment Vinyl with Aqua
AY	Pastel Parchment Vinyl with Nugget Gold
BU	Pastel Parchment Vinyl
CU	Pastel Parchment Vinyl
DU	Pastel Parchment Vinyl
EU	Pastel Parchment Vinyl
FA	Pastel Parchment Vinyl with Black
FB	Pastel Parchment Vinyl with Blue
FD	Pastel Parchment Vinyl with Red
FF	Pastel Parchment Vinyl with Saddle
FG	Pastel Parchment Vinyl with Ivy Gold
FK	Pastel Parchment Vinyl with Aqua
FU	Pastel Parchment Vinyl
FY	Pastel Parchment Vinyl with Nugget Gold
HA	Black Vinyl
HB	Dk. & Lt. Blue Vinyl
HD	Dk. Red Vinyl
HG	Med. & Lt. Ivy Gold Vinyl
HK	Dk. & Lt. Aqua Vinyl
HU	Pastel Parchment Vinyl
HY	Lt. Nugget Gold Vinyl
JU	Pastel Parchment Vinyl
KB	Med. Blue Cloth and Lt. Blue Vinyl
KG	Med. Ivy Gold Cloth and Lt. Ivy Gold Vinyl
KU	Lt. Parchment Cloth and Pastel Parchment Vinyl (Montego)
KU	Pastel Parchment Vinyl (Fairlane)
LA	Black Vinyl
LB	Lt. Blue Vinyl
LD	Dk. Red Vinyl
LU	Pastel Parchment Vinyl
MA	Black Vinyl
MB	Dk. & Lt. Blue Vinyl
MD	Dk. Red Vinyl
MU	Pastel Parchment Vinyl
OU	Pastel Parchment Vinyl
QA	Black Vinyl
QB	Dk. & Lt. Blue Vinyl
QU	Pastel Parchment Vinyl
RA	Black Vinyl
RB	Lt. Blue Vinyl
RD	Dk. Red Vinyl
RU	Pastel Parchment Vinyl
TU	Pastel Parchment Vinyl
UA	Parchment Vinyl with Black
UB	Parchment Vinyl with Blue
UD	Parchment Vinyl with Red
UF	Parchment Vinyl with Saddle
UG	Parchment Vinyl with Ivy Gold
UK	Parchment Vinyl with Aqua
UU	Pastel Parchment Vinyl
UY	Parchment Vinyl with Nugget Gold
YU	Pastel Parchment Vinyl
ZU	Pastel Parchment Vinyl

Brakes

GROUP

2

PART 2-1	PAGE	PART 2-3	PAGE
General Brake Service	2-1	Specifications	2-34
PART 2-2			
Brake System	2-9		

PART 2-1—General Brake Service

Section	Page	Section	Page
1 Diagnosis and Testing	2-1	Hydraulic System Bleeding and Centralizing of the Differential Valve.....	2-4
Brake System Tests	2-1	3 Cleaning and Inspection.....	2-5
Road Test	2-3	Disc (Front) Brakes	2-5
2 Common Adjustments and Repairs	2-3	Rear Brakes	2-6
Parking Brake Linkage Adjustment	2-3		
Power Brake Master Cylinder Push Rod Adjustment.....	2-4		

1 DIAGNOSIS AND TESTING

BRAKE SYSTEM TESTS

BRAKE FLUID LEVEL AND HYDRAULIC SYSTEM

1. Always check the fluid level in the brake master cylinder reservoirs before performing the test procedures. If the fluid level is not within 1/4 inch of the top of the master cylinder reservoirs, add the specified brake fluid. Add Ford Brake Fluid—Extra Heavy Duty—Part Number C6AZ-19542-A (ESA-M6C25-A) equivalent for all brake applications. **The extra heavy duty brake fluid is colored blue for identification purposes. Do not mix low temperature brake fluids with the specified brake fluid.**

DUAL MASTER CYLINDER BRAKE SYSTEM

1. Turn the ignition switch to the ACC or ON position. If the light on the brake warning lamp remains on, the condition may be caused by a defective switch, grounded switch wires or the differential pressure valve is not centered. Centralize the differential pressure valve as outlined under Hydraulic System Bleeding and Centralizing of the Differential Valve in this section of the manual. If the warning light remains on, check the switch connector and wire for a grounded condition and repair or replace the wire assembly.

If the condition of the wire is good, replace the brake warning lamp switch.

2. Turn the ignition switch to the start position. If the brake warning lamp does not light, check the light and wiring for defects and replace or repair wiring.

3. If the brake warning lamp does not light when a pressure differential condition exists in the brake system, the warning lamp may be burned out, the warning lamp switch is inoperative or the switch to lamp wiring has an open circuit. Check the bulb and replace it, if required. Check the switch to lamp wires for an open circuit and repair or replace them, if required. If the warning lamp still does not light, replace the switch.

BRAKE PEDAL FREE HEIGHT AND TRAVEL MEASUREMENTS

With the engine running for full power brake operation, measure the brake pedal free height, and check the brake pedal travel with the use of the Brake Pedal Pressure Gauge, Tool WRE-500-50 as follows:

Brake Pedal Free Height Measurement

1. Insert a slender, sharp pointed prod through the carpet and sound

deadner to the dash panel metal and measure the distance to the brake pedal (Fig. 1).

2. If the position of the pedal is not within specification, check the brake pedal linkage for missing, worn or damaged bushings or loose attaching bolts and replace them, if required.

3. If the pedal free height is still out of specification, check the brake pedal booster push rod (if so equipped) or master cylinder to be sure the correct parts are installed. Replace the defective parts as necessary.

Brake Pedal Travel Measurement

1. Install a Brake Pedal Pressure Gauge on the brake pedal pad (Fig. 2).

2. Hook a steel measuring tape to the brake pedal as shown in Fig. 1. Measure and record the distance from the brake pedal free height position to the reference point, which is at the six o'clock position on the steering wheel rim.

3. With the steel tape still hooked to the brake pedal depress the brake by pressing downward on the brake pedal effort gauge. Apply a 50 pound load to the center of the pedal by observing the pressure gauge, and measure the distance from the brake pedal to the fixed reference point on the steering wheel rim, par-

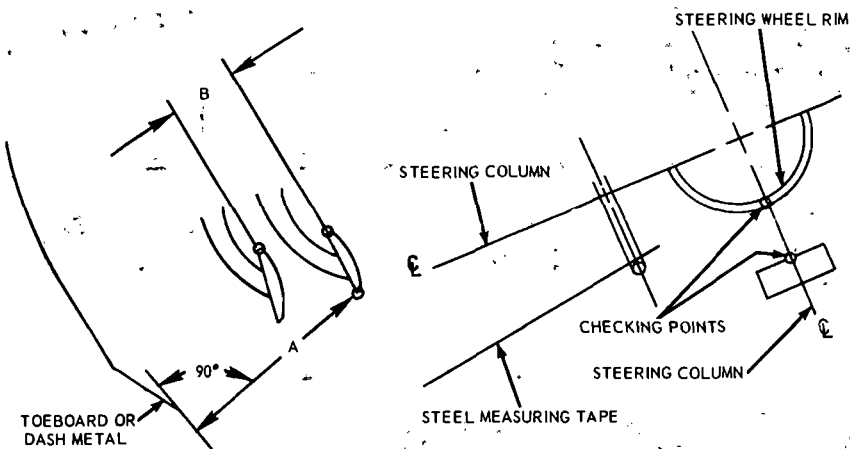

VEHICLE	TYPE	PEDAL FREE HEIGHT A	PEDAL TRAVEL B
FALCON— MONTEGO —FAIRLANE	NON-POWER DRUM	8.13 6.91	2.73
FALCON— MONTEGO —FAIRLANE	POWER DISC	7.20 5.82	2.10
MUSTANG—COUGAR	NON-POWER DRUM	7.32 6.37	2.68
MUSTANG—COUGAR	POWER DISC	6.20 5.33	1.85

NOTE: A DIMENSION TO BE MEASURED TO SHEET METAL

B DIMENSION TO BE MEASURED PARALLEL TO THE VERTICAL CENTERLINE OF THE STEERING COLUMN WITH A 50 POUND LOAD APPLIED TO THE CENTERLINE OF THE BRAKE PEDAL PAD. (CHECKS ON POWER BRAKE VEHICLES MADE WITH ENGINE RUNNING) H 1551 - B

FIG. 1—Brake Pedal Height and Travel Measurements

Tool—WRE-500-50

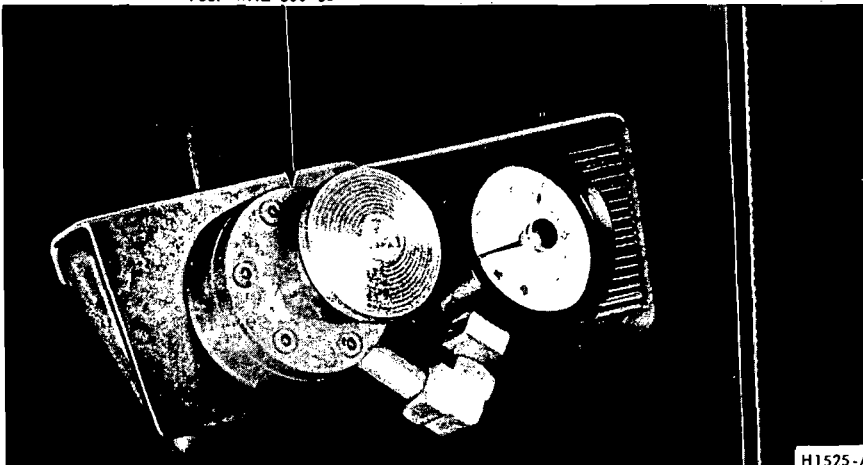

FIG. 2—Brake Pedal Effort Gauge Installed—Typical

allel to the centerline of the steering column.

4. The difference between the brake pedal free height and the depressed pedal measurement under a 50 pound load should be within the specified maximum pedal travel service specification B in Fig. 1.

5. If the pedal travel is more than the specified maximum shown in Fig. 1, dimension B, make several sharp reverse stops (equivalent to 50 pounds pedal pressure) with a forward stop before each. Move the car in reverse and forward for a dis-

tance of approximately ten feet; then apply the brakes sharply and hold the brake pedal down until the car is completely stopped. This will actuate the brake self-adjusters. If these stops do not bring the brake pedal travel within specification, make several additional forward and reverse stops as outlined above.

6. If the second series of stops do not bring the brake pedal travel within specification, remove the brake drums and check the brake adjusters to make sure they are functioning. Check the brake linings for

wear or damage. Repair or replace all worn or damaged parts and non-functioning adjusters. Adjust the brake lining outside diameter to the approximate inside diameter of the brake drum with Rotunda Tool HRE 8650 (Figs. 11 and 12, Part 2-2).

7. If all the brake adjusters, brake drums and linings are functional and the brake pedal travel is not within specifications, check the pedal linkage for missing, worn or damaged bushings, or loose attachments. Bleed the brake and centralize the differential valve.

POWER BRAKE FUNCTIONAL TEST

1. With the transmission in neutral, stop the engine and apply the parking brake. Depress the brake pedal several times to exhaust all vacuum in the system.

2. With the engine shut off, depress the brake pedal and hold it in the applied position. If the pedal gradually falls away under this pressure, the hydraulic system is leaking. Check all tubing, hoses, calipers (if so equipped), wheel cylinders and connections for leaks.

If the brake pedal movement feels spongy, bleed the hydraulic system to remove air from the system. Refer to Hydraulic System Bleeding, Part 1, Section 2. Also, check for leaks or insufficient fluid.

3. With the engine shut off and all vacuum in the system exhausted, depress the pedal and hold it in the applied position. Start the engine. If the vacuum system is operating, the pedal will tend to fall away under foot pressure and less pressure will be required to hold the pedal in the applied position. If no action is felt, the vacuum booster system is not functioning.

LOCKED WHEEL BRAKE

Should one of the wheel brakes be locked and the vehicle must be moved, open the bleeder screw long enough to let out a few drops of brake fluid. This bleeding operation will release the brakes but will not correct the cause of trouble.

PARKING BRAKE

Visually check the operation of the parking brake linkage as the parking brake controls are moved to the applied position. Then, check the operation of the brake linkage when the parking brake controls are moved to

the released position. These checks should indicate whether the manual parking brake control linkage is operating properly or requires repair or adjustment due to inability of the parking brake to hold against moderate vehicle movement.

ROAD TEST

A road test should only be con-

ducted when the operator is sure the brakes will stop the vehicle.

During a road test, apply the vehicle's brakes at a road speed of 20 mph for all problem conditions listed in Figs. 11 and 12 with the exception of those resolved in the Brake System Tests and brake chatter. To check for brake chatter or surge, apply the brakes lightly at 50 mph. For each of the symptoms encountered, check and

eliminate the causes which are listed in Figs. 11 and 12.

If the road test reveals one or more problem conditions listed in Figs. 11 and 12, correct all malfunctions of the vacuum system, brake booster and hydraulic system prior to removing brake drums, brake calipers (if so equipped), brake shoes and linings or backing plates.

2 COMMON ADJUSTMENTS AND REPAIRS

PARKING BRAKE LINKAGE ADJUSTMENT

MUSTANG—COUGAR

Check the parking brake cables when the parking brakes are fully released. If the cables are loose, adjust them as follows:

1. Fully release the parking brake by turning the handle counterclockwise and pushing it inward.

2. Pull the parking brake handle outward to third notch from its normal released position.

3. Raise the vehicle. Remove the wheel cover. Install Tool T66L-4204-L on the rear wheel (Fig. 3).

4. Turn the locking adjustment nut forward against the cable guide on the equalizer (Fig. 4) until there is 100 ft-lbs break-away torque at the rear wheel when turning the rear wheels in the direction of forward rotation with a torque wrench (Fig. 3). The torque measurement must be made relative to the centerline of the wheel.

5. Release the parking brake and make sure the brake shoes return to the fully released position and no drag is felt when turning the rear wheels.

6. Remove Tool T66L-4204-L. Install the wheel attaching bolts and torque them to specification. Install the wheel cover. Lower the vehicle.

MONTEGO—FALCON—FAIRLANE

Check the parking brake cables when the brakes are fully released.

If the cables are loose, adjust them as follows:

1. Fully release the parking brake pedal.

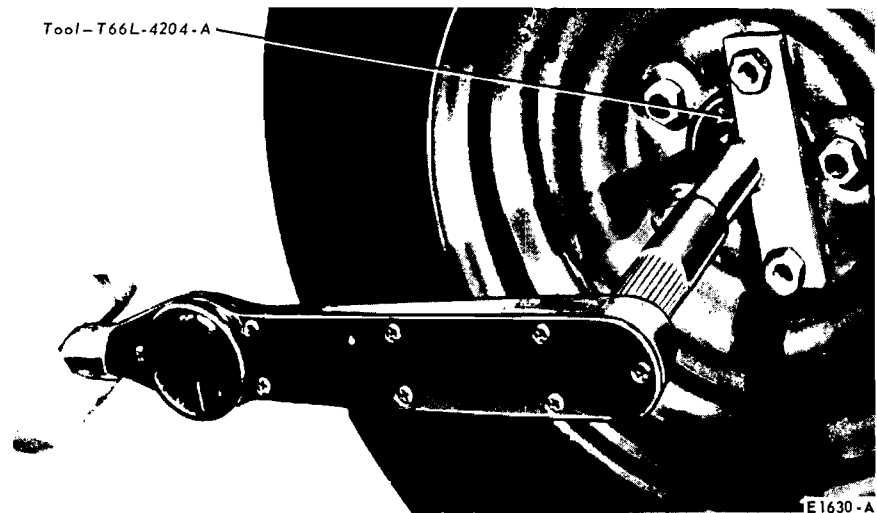

FIG. 3—Checking Parking Brake Break-Away Torque

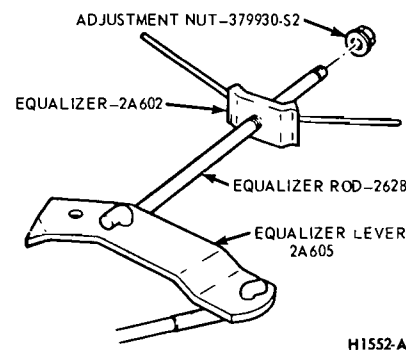

FIG. 4—Parking Brake Linkage Adjustment—Mustang and Cougar

2. Push the parking brake pedal to the first notch from the normal released position.

3. Raise the vehicle. Loosen the equalizer lock nut (Fig. 5) and turn the nut forward against the cable guide on the equalizer until there is 75-100 pounds tension on the left rear cable or there is 100 ft-lbs break-away torque when turning the rear

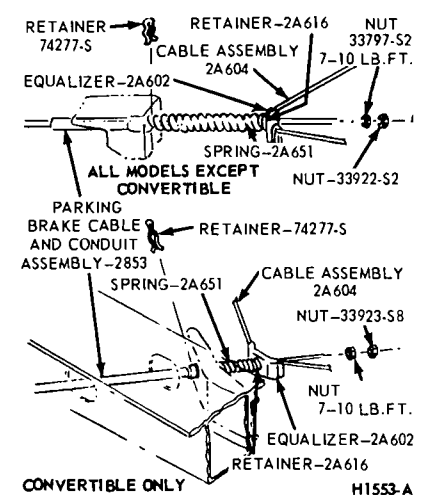

FIG. 5—Parking Brake Linkage Adjustment—Montego, Fairlane and Falcon

wheels in the direction of forward rotation with a torque wrench and Tool T66L-4204-L as shown in Fig. 3.

The torque measurement must be made relative to the centerline of the wheel. Tighten the lock nut.

4. Make sure there is no drag when turning the rear wheels.

5. Lower the vehicle. Remove the torque wrench and Tool T66L-4204-L, if required. Install the wheel attaching nuts and torque them to specification. Install the wheel cover.

POWER BRAKE MASTER CYLINDER PUSH ROD ADJUSTMENT

The push rod is provided with an adjustment screw to maintain the correct relationship between the booster control valve plunger and the master cylinder pistons. Failure to maintain this relationship will prevent the master cylinder piston from completely releasing hydraulic pressure and can cause the brakes to drag, or cause excessive brake pedal travel.

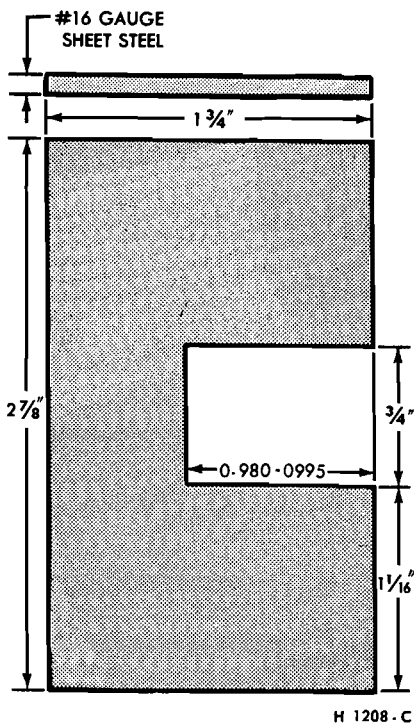

FIG. 6—Push Rod Gauge Dimensions

To check the adjustment of the screw, fabricate a gauge of the dimension shown in Fig. 6. Then place the gauge against the master cylinder mounting surface of the booster body as shown in Figs. 7 or 8. The push rod screw should be adjusted so that the end of the screw just touches the inner edge of the slot in the gauge. Do not set up side forces on the push rod. Side forces may break

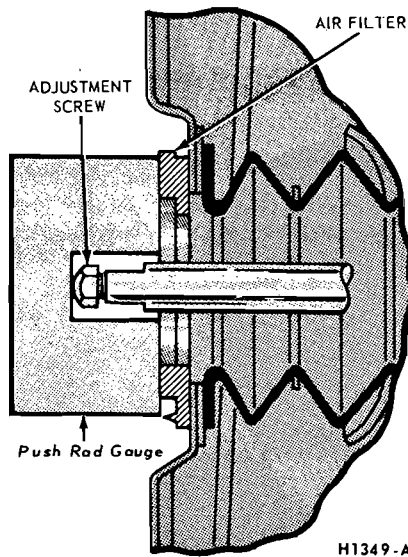

FIG. 7—Push Rod Adjustment—Midland-Ross

the valve plunger.

This is an approximate adjustment only. The push rod should not move more than 0.015 inch as it contacts the master cylinder piston. No movement (exact contact) is ideal.

HYDRAULIC SYSTEM BLEEDING AND CENTRALIZING OF THE DIFFERENTIAL VALVE

When any part of the hydraulic system has been disconnected for repair or replacement, air may enter the system and cause spongy pedal action. Bleed the hydraulic system after it has been properly connected, to be sure that all air is expelled.

MANUAL BLEEDING

The primary and secondary (front and rear) hydraulic brake systems are individual systems and are bled separately. Bleed the longest line first on the individual system being serviced. During the complete bleeding operation, **DO NOT allow the reservoir to run dry.** Keep the master cylinder reservoirs filled with Rotunda Fluid—Extra Heavy Duty—Part Number C6AZ-19542-A. The extra heavy duty brake fluid is colored blue for identification purposes. Do not mix low temperature brake fluids with the specified fluid during the bleeding operations. Never re-use brake fluid which has been drained from the hydraulic system.

1. Loosen the bleed screw located on the side of the master cylinder. Do not use the secondary piston stop screw, located on the bottom of the master cylinder to bleed the brake

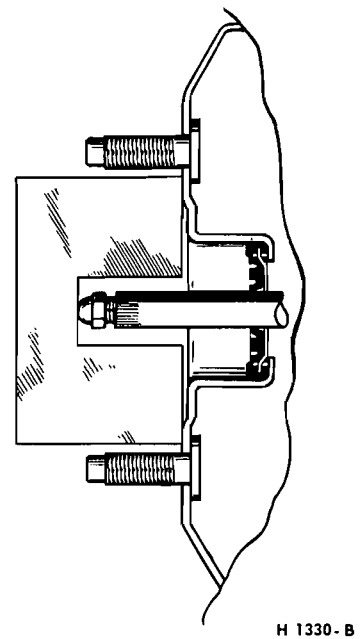

FIG. 8—Push Rod Adjustment—Bendix

system. Loosening or removing this screw could result in damage to the secondary piston or stop screw.

2. To bleed the secondary (rear) brake system, position a suitable 3/8 inch box wrench (Fig. 9) on the bleeder fitting on the brake wheel cylinder. Attach a rubber drain tube to the bleeder fitting. The end of the tube should fit snugly around the bleeder fitting.

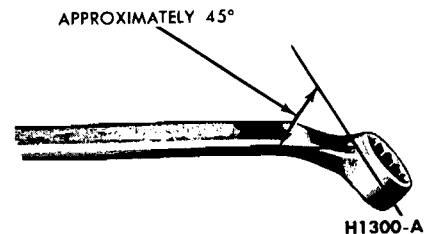

FIG. 9—Wrench for Bleeding Brake Hydraulic System

3. Submerge the free end of the tube in a container partially filled with clean brake fluid, and loosen the bleeder fitting approximately 3/4 turn.

4. Push the brake pedal down slowly through its full travel. Close the bleeder fitting, then return the pedal to the fully-released position. Repeat this operation until air bubbles cease to appear at the submerged end of the bleeder tube.

5. When the fluid is completely free of air bubbles, close the bleeder fitting and remove the bleeder tube.

6. Repeat this procedure at the brake wheel cylinder on the opposite side. Refill the master cylinder reservoir after each wheel cylinder is bled

and install the master cylinder cover and gasket. **Be sure the diaphragm type gasket is properly positioned in the master cylinder cover. When the bleeding operation is completed, the fluid level should be filled to within 1/4 inch from the top of the reservoirs.**

7. If the primary (front brake) system is to be bled, repeat steps 2 through 6 at the right front brake caliper or cylinder and ending at the left front brake caliper or cylinder.

8. On disc brake equipped vehicles be sure that the front brake pistons are returned to their normal positions and that the shoe and lining assemblies are properly seated by depressing the brake pedal several times until normal pedal travel is established.

9. Centralize the pressure differential valve. Refer to the Centralizing the Pressure Differential Valve Procedures which follow.

PRESSURE BLEEDING

Bleed the longest lines first. The bleeder tank should contain enough new Ford Brake Fluid to complete the bleeding operation. Use Ford brake fluid—Extra Heavy Duty · Part Number C6AZ-19542-A or equivalent for all brake applications. **The brake fluid is colored blue for identification purposes. Do not mix low temperature brake fluid with specified brake fluid during the bleeding operations. Never re-use brake fluid that has been drained from the hydraulic system.** The tank should be charged with approximately 10 to 30 pounds of air pressure. **Never exceed 50 pounds pressure.**

1. Clean all dirt from the master cylinder reservoir cover.

2. Remove the master cylinder reservoir cover and rubber gasket, and fill the master cylinder reservoir with the specified brake fluid. Install the pressure bleeder adapter tool to the master cylinder, and attach the bleeder tank hose to the fitting on the adapter.

Master cylinder pressure bleeder adapter tools can be obtained from the various manufacturers of pressure

bleeding equipment. Follow the instructions of the manufacturer when installing the adapter.

3. Loosen the primary and secondary tube nuts at the master cylinder and bleed the master cylinder until the fluid flow is free of air bubbles, then tighten the tube nuts to the specified torque. Refer to Figs. 20 and 21, Part 2-2. **Do not overtighten the nuts.**

4. If the rear wheel cylinders, secondary brake system, are to be bled, position a 3/8 inch box wrench (Fig. 9) on the bleeder fitting on the right rear brake wheel cylinder. Attach a bleeder tube to the bleeder fitting. **The end of the tube should fit snugly around the bleeder fitting.**

5. Open the valve on the bleeder tank to admit pressurized brake fluid to the master cylinder reservoir.

6. Submerge the free end of the tube in a container partially filled with clean brake fluid, and loosen the bleeder fitting.

7. When air bubbles cease to appear in the fluid at the submerged end of the bleeder tube, close the bleeder fitting and remove the tube.

8. Repeat steps 3 through 7 at the left rear wheel cylinder.

9. If the vehicle is equipped with disc brakes, repeat steps 4 through 7, starting at the right front disc caliper and ending at the left front disc caliper.

10. If the vehicle contains drum-type front brakes and the primary (front) brake system is to be bled, repeat steps 4 through 7, starting at the right front wheel cylinder and ending at the left wheel cylinder.

11. When the bleeding operation is completed, close the bleeder tank valve and remove the tank hose from the adapter fitting.

12. On disc brake equipped vehicles, be sure that the front brake pistons are returned to their normal positions and that the shoe and lining assemblies are properly seated by depressing the brake pedal several times until normal pedal travel is obtained.

13. Remove the Pressure Bleeder Adapter Tool. Fill the master cylinder

reservoirs to within 1/4 inch from the top. Install the master cylinder cover and gasket. **Be sure the diaphragm-type gasket is properly positioned in the master cylinder cover.**

14. Centralize the pressure differential valve as follows:

CENTRALIZING THE PRESSURE DIFFERENTIAL VALVE

After a failure of the primary (front brake) or secondary (rear brake) system has been repaired and bled, the dual-brake warning light will usually continue to be illuminated due to the pressure differential valve remaining in an off-center position.

To centralize the pressure differential valve and turn off the warning light after a repair operation, a pressure differential or unbalance condition must be created in the opposite brake system from the one that was repaired and bled last.

1. Turn the ignition switch to the ACC or ON position. Loosen the differential valve assembly brake tube nut at the outlet port on the **opposite side of the brake system that was repaired and/or bled last.** Depress the brake pedal slowly to build line pressure until the pressure differential valve is moved to a centralized position and the brake warning light goes out; then, immediately tighten the outlet port tube nut to the specified torque. Refer to Fig. 18 and 19.

2. Check the fluid level in the master cylinder reservoirs and fill them to within 1/4 inch of the top with the specified brake fluid, if necessary.

3. Turn the ignition switch to the OFF position.

4. Before driving the vehicle, check the operation of the brakes and be sure that a firm pedal is obtained.

3 CLEANING AND INSPECTION

DISC (FRONT) BRAKES

1. Remove the wheel and tire and the shoe and lining assemblies as outlined in Part 2-2, Section 2.

2. Make a thickness measurement with a micrometer across the

thinnest section of the shoe and lining. If the assembly has worn to a thickness of 0.230 inch (shoe and lining together) or 0.030 inch (lining material only) at the thinnest point or if the brake lining shows evidence of brake fluid contamination, replace all four

shoe and lining assemblies on both front wheels.

3. Check the caliper to spindle attaching bolt and torque. Tighten them to the specified torque, if required.

4. To check rotor runout, first