

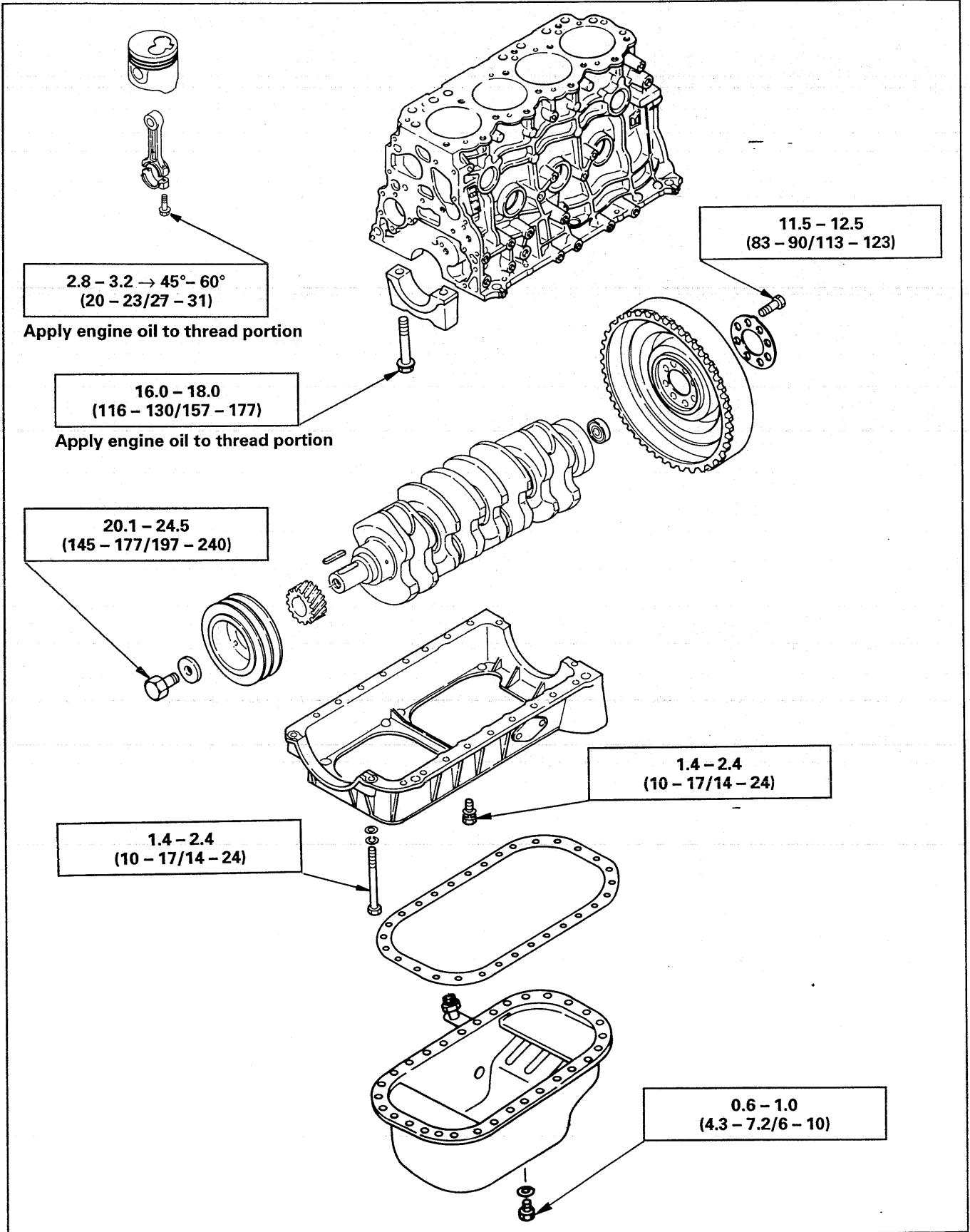

Crankshaft Bearing Cap, Connecting Rod Bearing Cap, Crankshaft Damper Pulley, Flywheel, and Oil Pan

kg·m(lb.ft./N·m)





Timing Gear Case, Flywheel Housing, Camshaft, and Timing Gear

kg·m(lb.ft./N·m)

M10 x 1.25	3.6 – 4.6 (26 – 33/35 – 45)
M12 x 1.5	7.5 – 9.3 (54 – 67/74–91)

1.4 – 2.4
(10 – 17/14 – 24)

1.4 – 2.4
(10 – 17/14 – 24)

10.0 – 12.0
(72 – 87/98 – 118)

1.4 – 2.4
(10 – 17/14 – 24)

2.1 – 3.1
(15 – 22/21 – 30)

1.0 – 1.5
(7 – 11/10 – 15)

9.5 – 11.5
(69 – 83/93 – 113)

(PKL)

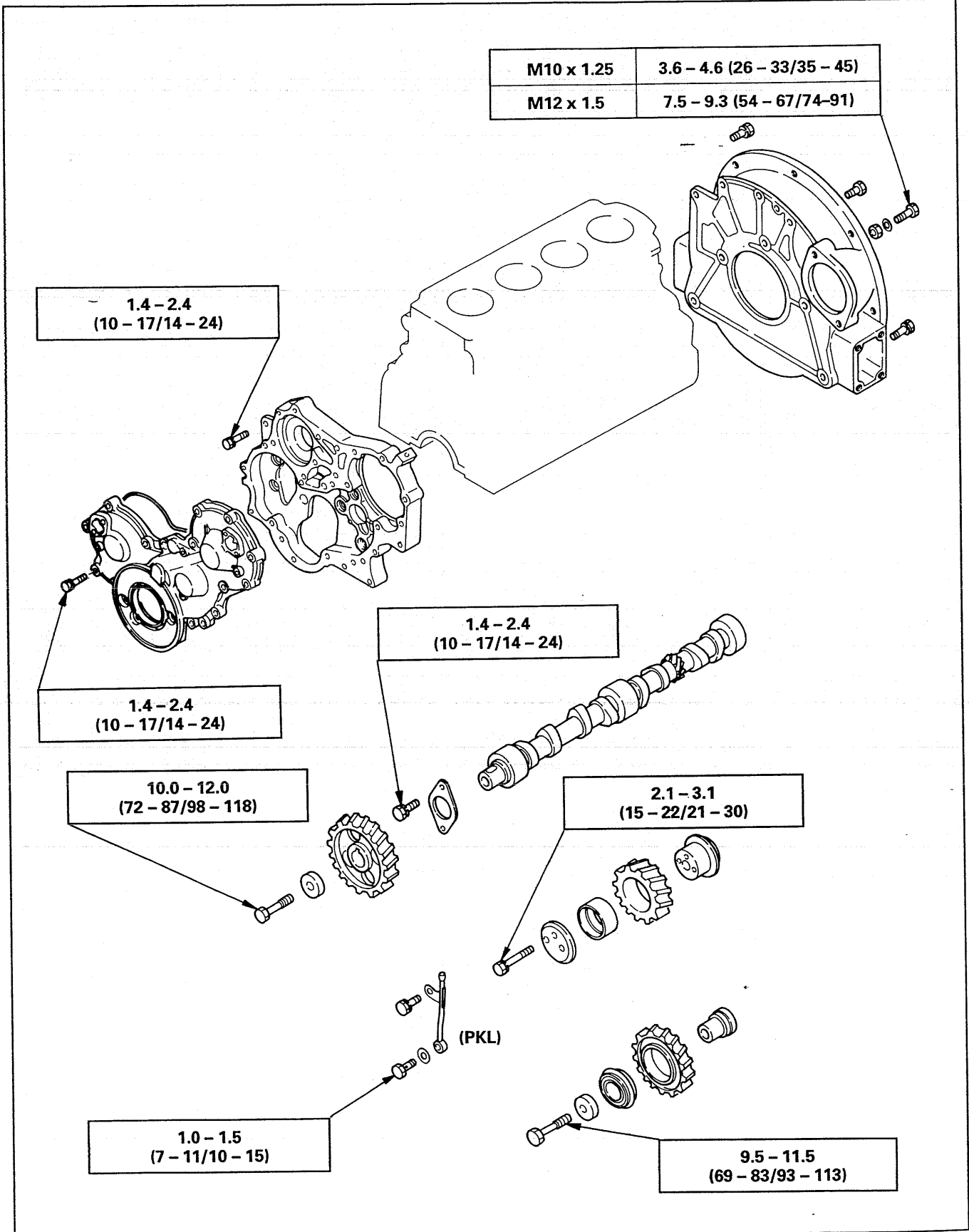



Cooling and Lubricating System

kg·m(lb.ft./N·m)

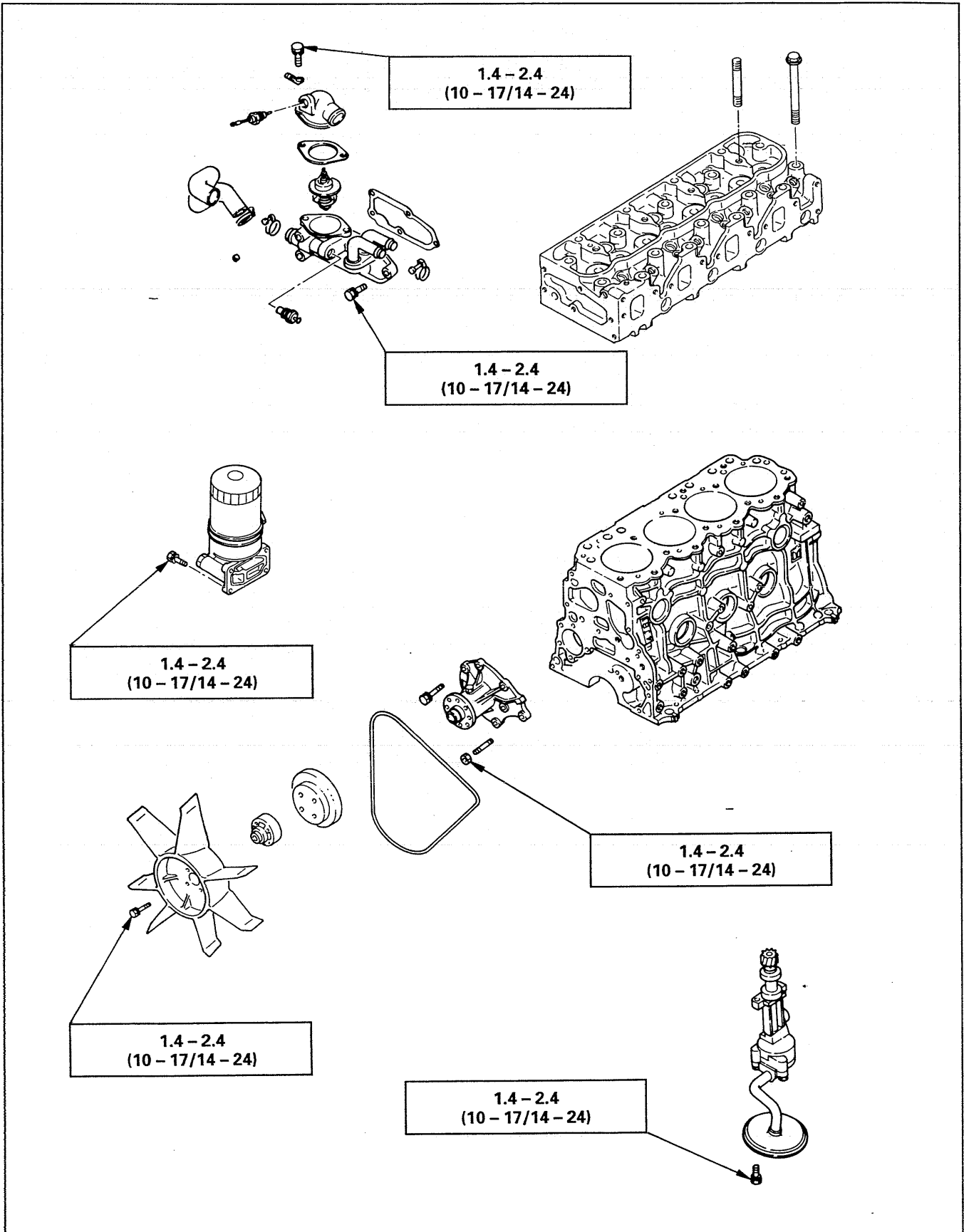



Intake and Exhaust Manifold

kg·m(lb.ft./N·m)

1.4 - 2.4
(10 - 17/14 - 24)

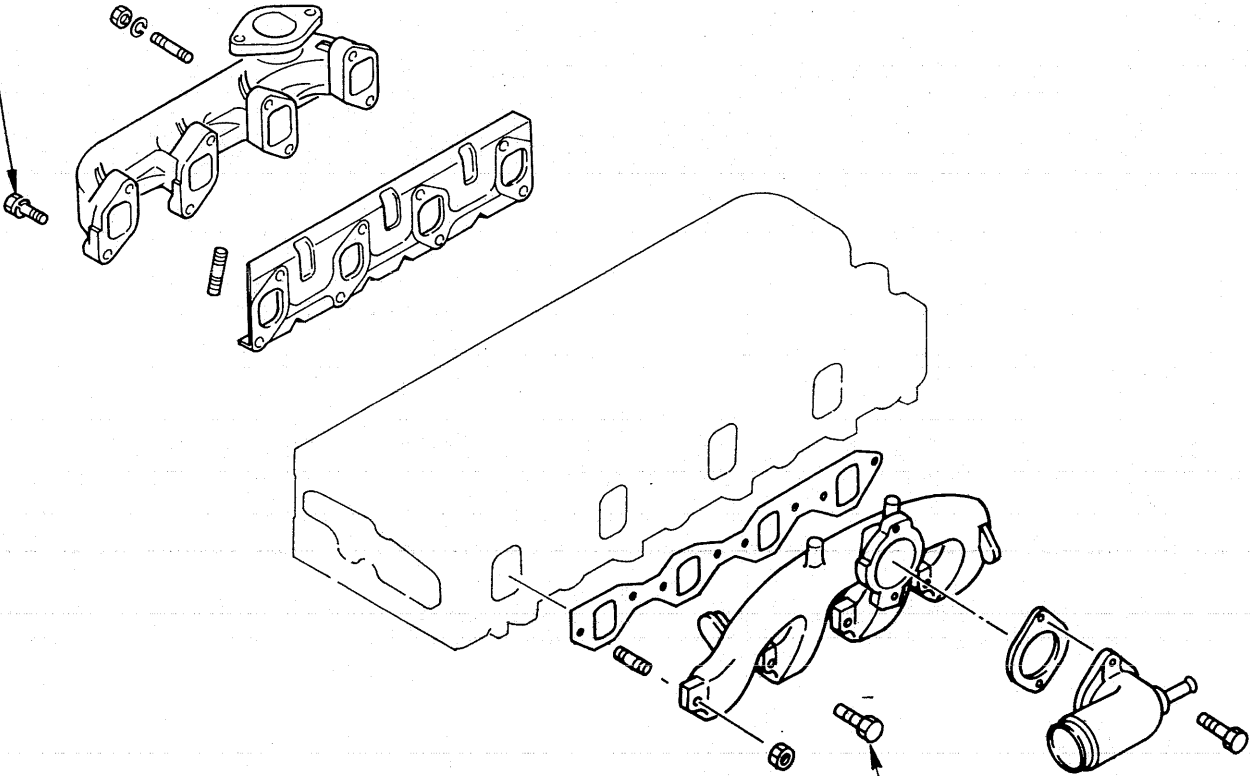

1.4 - 2.4
(10 - 17/14 - 24)