

Dump Body Remove and Install

-: Specifications

SPECIFICATIONS	
260E Dump Body Weight (approximate)	3800 kg 8377 lb
310E Dump Body Weight (approximate)	4200 kg 9259 lb
Cap Screw (2) Torque	320 N·m 236 lb·ft

MACHINE PREPARATION

1. Park and prepare machine for service safely. [See Park and Prepare for Service Safely](#) . (Group 0001.)
2. Turn battery disconnect switch to the OFF position. [See Battery Disconnect Switch](#) . (Operator's Manual.)
3. Disconnect dump body heater pipe, if equipped. [See Dump Body Heater Pipe Remove and Install](#) . (Group 0530.)
4. Remove tailgate, if equipped. [See Tailgate Remove and Install](#) . (Group 3540.)
5. Remove dump body lift cylinders. [See Dump Body Lift Cylinder Remove and Install](#) . (Group 3560.)
6. Install identification tags and disconnect rear frame harness-to-rear lights connector (X40). [See Rear Lights Harness \(W21\) Component Location](#) . (Group 9015-10.)

REMOVAL

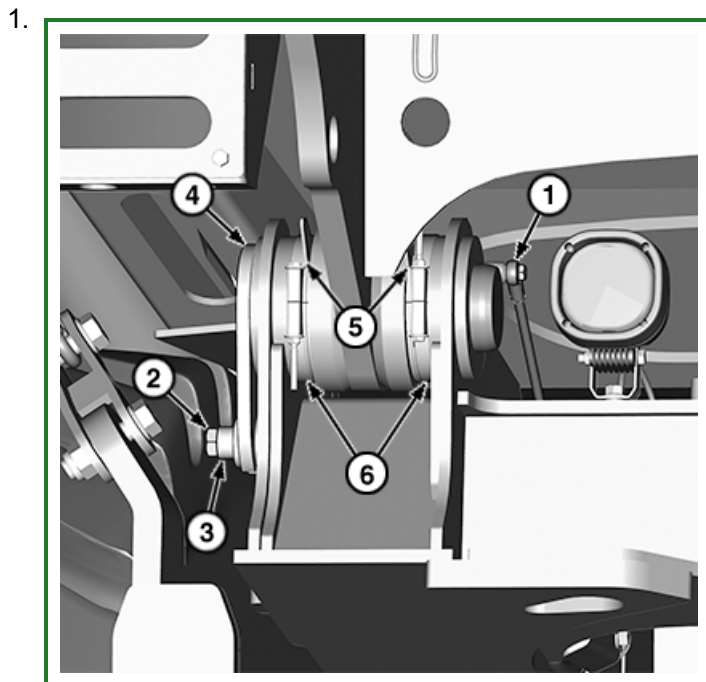

TX1233425A-UN: Dump Body Pivot Pin (left side shown)

LEGEND:

- 1 - Dump Body Position Sensor Linkage Rod
- 2 - Cap Screw (2 used)
- 3 - Bushing (2 used)
- 4 - Pivot Pin (2 used)

- 5 - Shim (as required)
- 6 - Outer Seal Ring (4 used)

Remove dump body position sensor linkage rod (1).

2.

⚠ CAUTION:

Prevent possible crushing injury from heavy component. Use appropriate lifting device.

Attach appropriate lifting device to dump body.

Item	Measurement	Specification
260E Dump Body	Weight (approximate)	3800 kg 8377 lb
310E Dump Body	Weight (approximate)	4200 kg 9259 lb

- 3. Remove cap screws (2) and bushings (3).
- 4. Remove outer seal rings (6).
- 5. Remove pivot pins (4) and shims (5).
- 6. Remove dump body from machine.
- 7. Inspect, clean, and replace parts as necessary.

INSTALLATION

Installation is reverse of removal procedure.

- Tighten cap screws (2) to specification.

Item	Measurement	Specification
Cap Screw (2)	Torque	320 N·m 236 lb·ft

- Align dump body if necessary. [See Dump Body Align . \(Group 3540.\)](#)
- Adjust dump body position sensor linkage. [See Dump Body Position Sensor Adjustment . \(Group 9015-20.\)](#)

Go to [Section_35:Group_3540](#)

M48R7EP,00000EE-19-20201116