

# SFI SYSTEM

## PRECAUTION

### 1. INITIALIZATION

#### NOTICE:

- Perform the **RESET MEMORY (AT initialization)** when replacing the automatic transmission assembly, engine assembly or ECM (See page [AT-19](#)).
- Perform the **REGISTRATION (VIN registration)** when replacing the ECM (See page [ES-15](#)).
- If the ECM has been replaced or **RESET MEMORY (AT initialization)** has been performed, set up the function of the ATF (Automatic Transmission Fluid) temperature warning light (See page [AT-19](#)).

#### HINT:

Initialization can not be completed by only removing the battery.

### 2. FOR USING INTELLIGENT TESTER

#### CAUTION:

##### Observe the following items for safety reasons:

- Read its instruction books before using the tester.
- Prevent the tester cable from being caught on the pedals, shift lever and steering wheel when driving with the tester connected to the vehicle.
- When driving the vehicle for testing purposes using the tester, two persons are required. One is for driving the vehicle, and the other operates the tester.

### 3. DISCONNECT AND RECONNECT CABLE OF NEGATIVE BATTERY TERMINAL

- Before performing electronic work, disconnect the cable from the negative (-) battery terminal in order to prevent it from shorting and burning out.
- Before disconnecting and reconnecting the battery cable, turn the ignition switch OFF and the headlight dimmer switch OFF. Then loosen the terminal nut completely. Do not damage the cable or terminal.
- When the battery cable is disconnected, the clock and radio settings and stored DTCs are erased. Therefore, before disconnecting the battery cable, make a notes of them.

#### NOTICE:

**When the cable is disconnected from the negative (-) battery terminal, initialize the following system(s) after the cable is reconnected.**

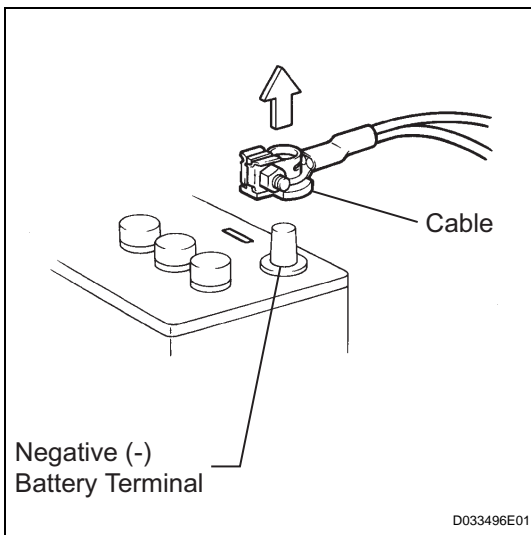

System name	See procedure
METER / GAUGE SYSTEM	<a href="#">ME-10</a>

## DEFINITION OF TERMS

Terms	Definitions
Monitor Description	Description of what ECM monitors and how detects malfunctions (monitoring purpose and details)
Related DTCs	A group of diagnostic trouble codes that are output by ECM based on same malfunction detection logic.
Typical Enabling Conditions	Preconditions that allow ECM to detect malfunctions. With all preconditions satisfied, ECM sets DTC when monitored value(s) exceeds malfunction threshold(s)
Sequence of Operation	Order of monitor priority, applied if multiple sensors and components involved in single malfunction detection process. Each sensor and component monitored in turn and not monitored until previous detection operation completed.
Required Sensors/Components	Sensors and components used by ECM to detect each malfunction.
Frequency of Operation	Number of times ECM checks for each malfunction during each driving cycle. "Once per driving cycle" means ECM only performs checks for that malfunction once during single driving cycle. "Continuous" means ECM performs checks for that malfunction whenever enabling conditions met.
Duration	Minimum time for which ECM must detect continuous deviation in monitored value(s) in order to set DTC. Timing begins when Typical Enabling Conditions met.
Malfunction Thresholds	Values, beyond which, ECM determines malfunctions exist and sets DTCs.
MIL Operation	Timing of MIL illumination after defect detected. "Immediate" means ECM illuminates MIL as soon as malfunction detected. "2 driving cycles" means ECM illuminates MIL if same malfunction detected second time during next sequential driving cycle.

# PARTS LOCATION

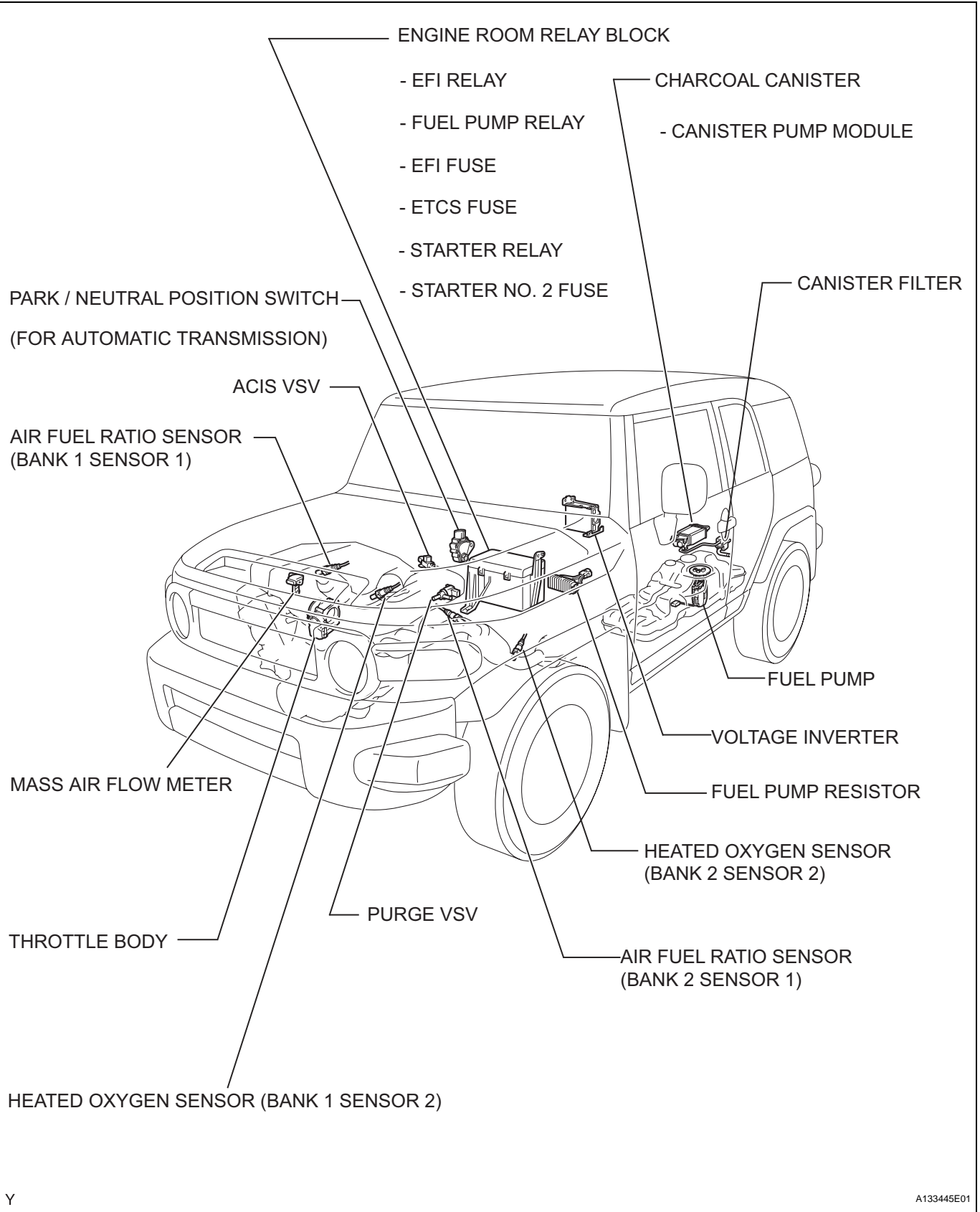

ES

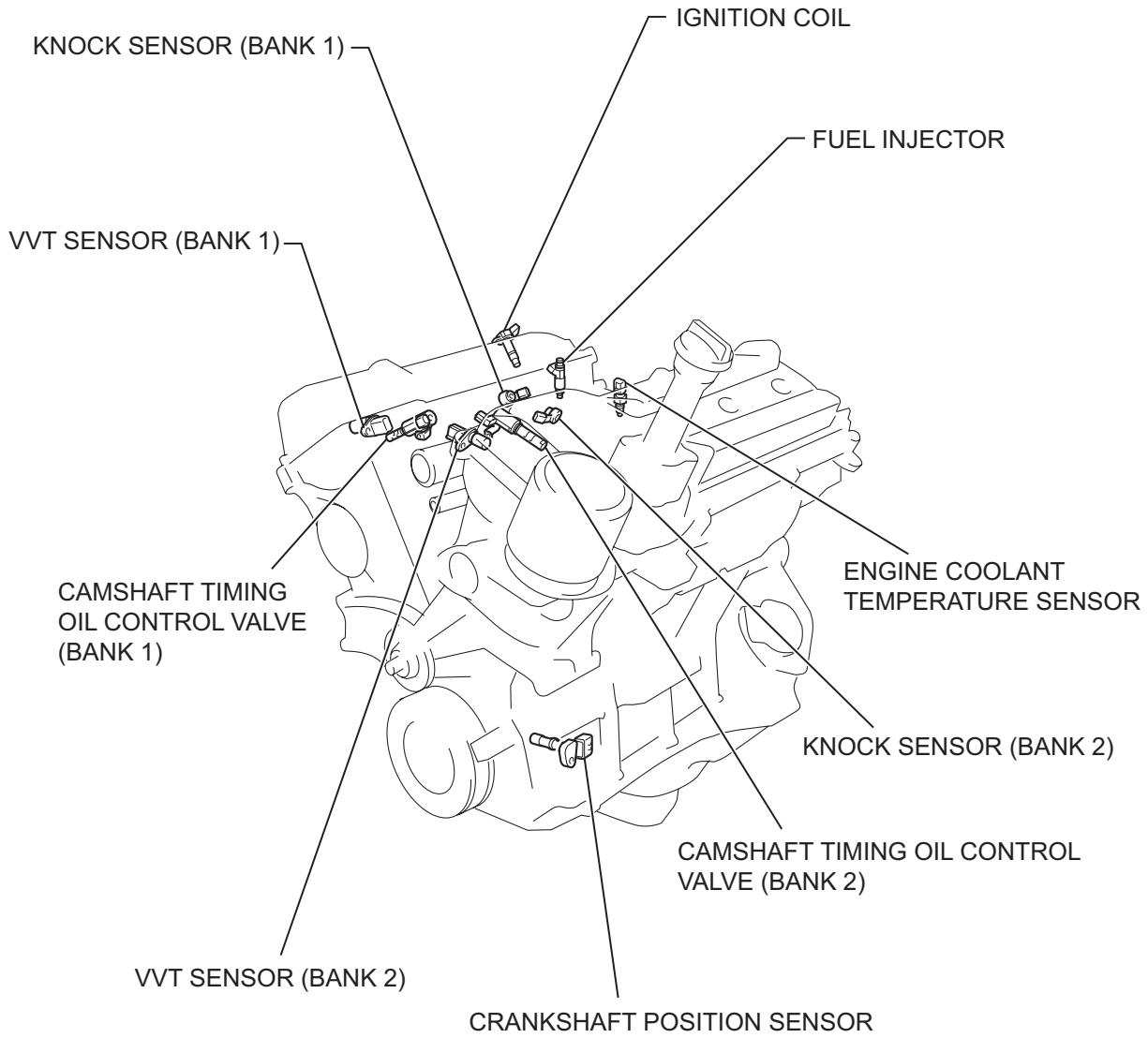

Y

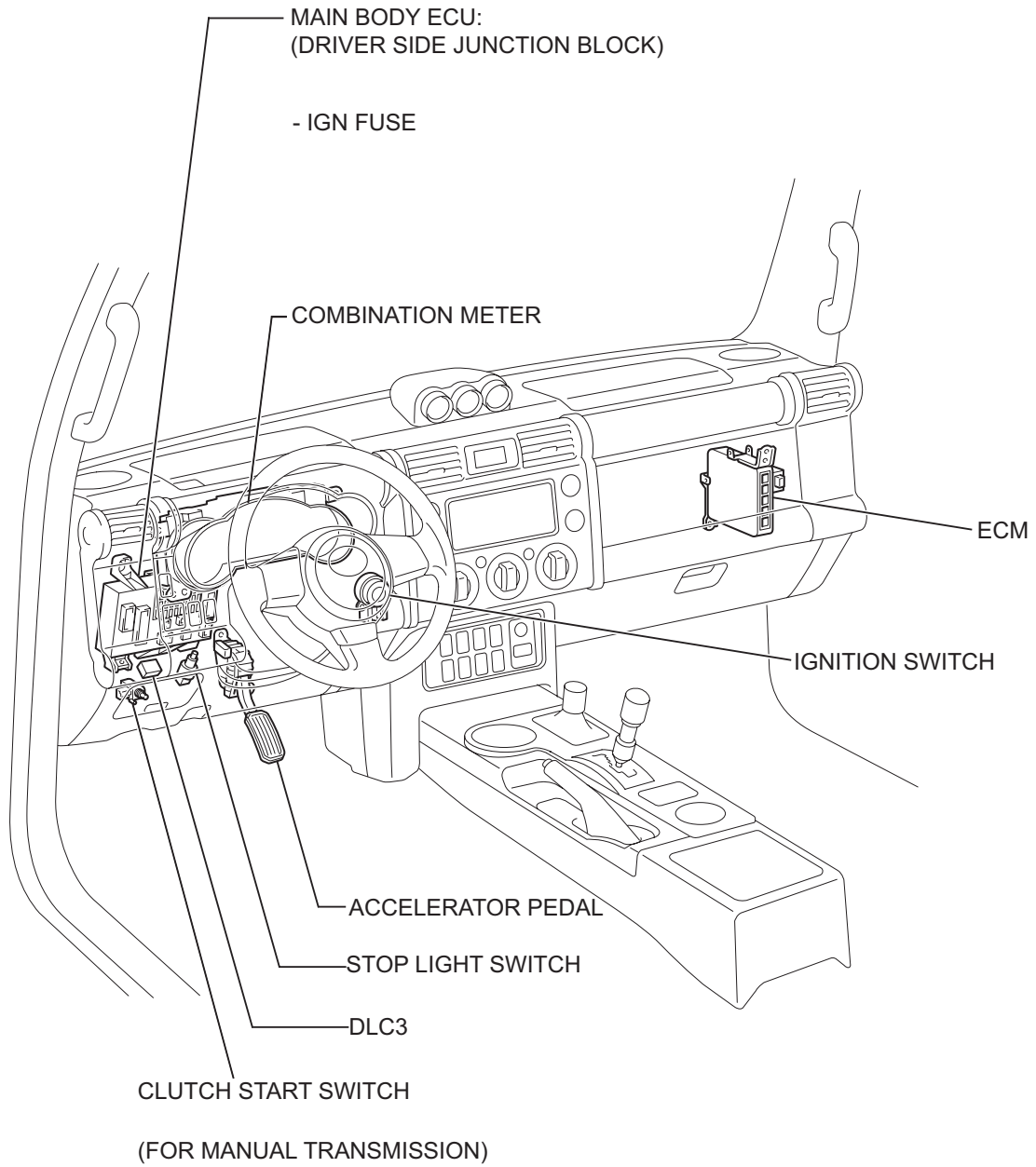

Y

# SYSTEM DIAGRAM

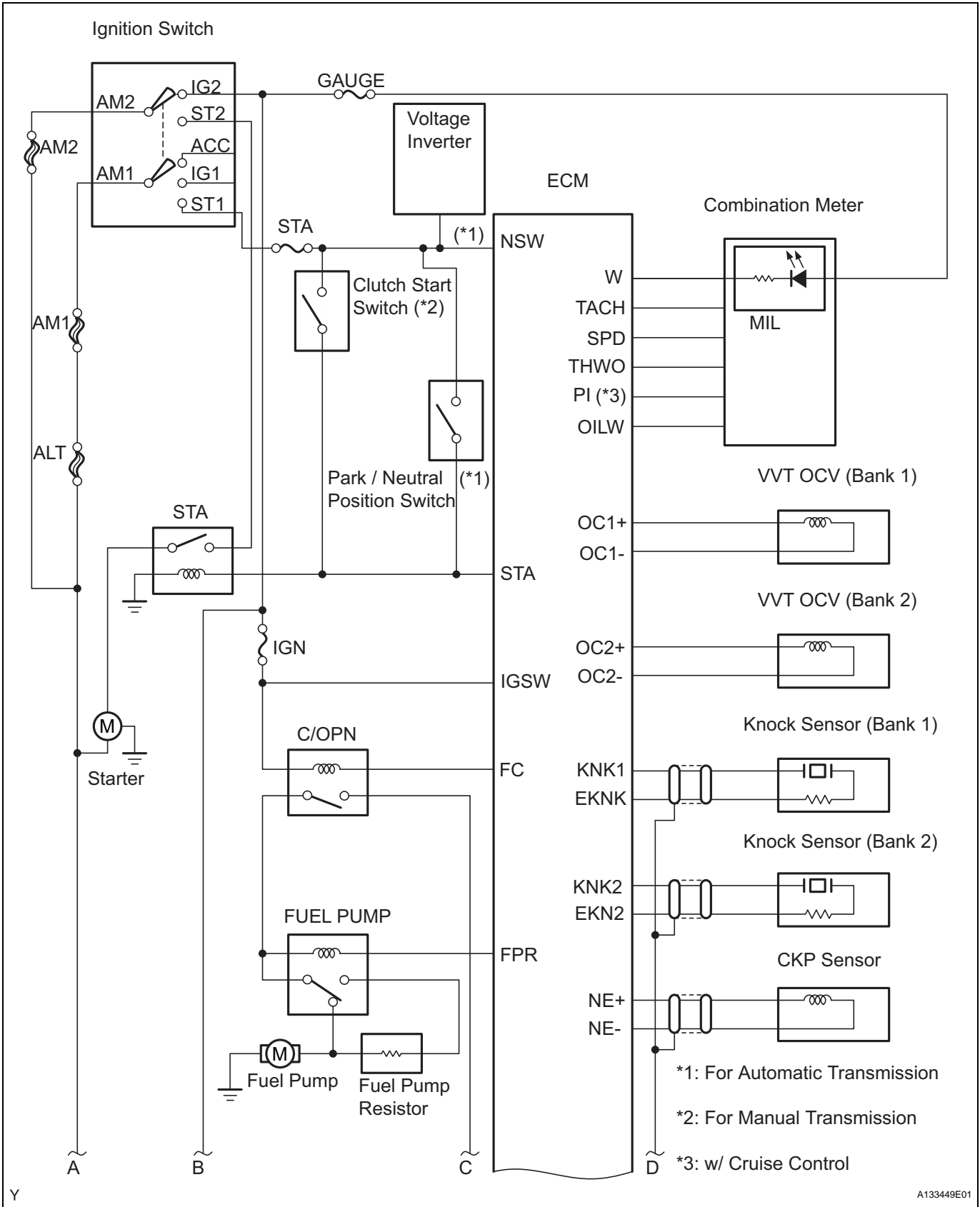

ES

Y

A13349E01