

CONTENTS

	Pagina
10. STRUCTURE AND FUNCTION	10-1
20. TESTING AND ADJUSTING	20-1
30. DISASSEMBLY AND ASSEMBLY	30-1
90. OTHER.....	90-1

**PAGE INTENTIONALLY
LEFT BLANK**

REVISED PAGES

The affected pages are indicated by the use of the following marks. It is requested that necessary actions be taken to these pages according to table below.

Mark	Indication	Action required
○	Page to be newly	Add
●	Page to be replaced	Replace
()	Page to be delete	Discard

Pages having no marks are those previously revised or made additions.

Mark	Page	Time of revision	Mark	Page	Time of revision	Mark	Page	Time of revision	Mark	Page	Time of revision	Mark	Page	Time of revision
	00-1			10-16			10-59			20-13			20-56	
	00-2			10-17			10-60			20-14			20-57	
	00-3			10-18			10-61			20-15			20-58	
	00-4			10-19			10-62			20-16			20-59	
	00-5			10-20			10-63			20-17			20-60	
	00-6			10-21			10-64			20-18			20-61	
	00-7			10-22			10-65			20-19			20-62	
	00-8			10-23			10-66			20-20			20-63	
	00-9			10-24			10-67			20-21			20-64	
	00-10			10-25			10-68			20-22			20-65	
	00-11			10-26			10-69			20-23			20-66	
	00-12			10-27			10-70			20-24			20-67	
	00-13			10-28			10-71			20-25			20-68	
	00-14			10-29			10-72			20-26			20-69	
	00-15			10-30			10-73			20-27			20-70	
	00-16			10-31			10-74			20-28			20-71	
	00-17			10-32			10-75			20-29			20-72	
	00-18			10-33			10-76			20-30			20-73	
	00-19			10-34			10-77			20-31			20-74	
	00-20			10-35			10-78			20-32			20-75	
	00-21			10-36			10-79			20-33			20-76	
	00-22			10-37			10-80			20-34			20-77	
	00-23			10-38			10-81			20-35			20-78	
	00-24			10-39			10-82			20-36			20-79	
				10-40			10-83			20-37			20-80	
				10-41			10-84			20-38			20-81	
				10-42			10-85			20-39			20-82	
				10-43			10-86			20-40			20-83	
	10-1			10-44			10-87			20-41			20-84	
	10-2			10-45			10-88			20-42			20-85	
	10-3			10-46						20-43			20-86	
	10-4			10-47			20-1			20-44			20-87	
	10-5			10-48			20-2			20-45			20-88	
	10-6			10-49			20-3			20-46			20-89	
	10-7			10-50			20-4			20-47			20-90	
	10-8			10-51			20-5			20-48			20-91	
	10-9			10-52			20-6			20-49			20-92	
	10-10			10-53			20-7			20-50			20-93	
	10-11			10-54			20-8			20-51			20-94	
	10-12			10-55			20-9			20-52			20-95	
	10-13			10-56			20-10			20-53			20-96	
	10-14			10-57			20-11			20-54			20-97	
	10-15			10-58			20-12			20-55			20-98	

Mark	Page	Time of revision	Mark	Page	Time of revision	Mark	Page	Time of revision	Mark	Page	Time of revision	Mark	Page	Time of revision
	20-99			30-50			30-112			30-174			30-236	
	20-100			30-51			30-113			30-175			30-237	
	20-101			30-52			30-114			30-176			30-238	
	20-102			30-53			30-115			30-177			30-239	
	20-103			30-54			30-116			30-178			30-240	
	20-104			30-55			30-117			30-179			30-241	
	20-105			30-56			30-118			30-180			30-242	
	20-106			30-57			30-119			30-181			30-243	
	20-107			30-58			30-120			30-182			30-244	
	20-108			30-59			30-121			30-183			30-245	
	20-109			30-60			30-122			30-184			30-246	
	20-110			30-61			30-123			30-185			30-247	
				30-62			30-124			30-186			30-248	
	30-1			30-63			30-125			30-187			30-249	
	30-2			30-64			30-126			30-188			30-250	
	30-3			30-65			30-127			30-189			30-251	
	30-4			30-66			30-128			30-190			30-252	
	30-5			30-67			30-129			30-191			30-253	
	30-6			30-68			30-130			30-192			30-254	
	30-7			30-69			30-131			30-193			30-255	
	30-8			30-70			30-132			30-194			30-256	
	30-9			30-71			30-133			30-195			30-257	
	30-10			30-72			30-134			30-196			30-258	
	30-11			30-73			30-135			30-197			30-259	
	30-12			30-74			30-136			30-198			30-260	
	30-13			30-75			30-137			30-199			30-261	
	30-14			30-76			30-138			30-200			30-262	
	30-15			30-77			30-139			30-201			30-263	
	30-16			30-78			30-140			30-202			30-264	
	30-17			30-79			30-141			30-203			30-265	
	30-18			30-80			30-142			30-204			30-266	
	30-19			30-81			30-143			30-205			30-267	
	30-20			30-82			30-144			30-206			30-268	
	30-21			30-83			30-145			30-207			30-269	
	30-22			30-84			30-146			30-208			30-270	
	30-23			30-85			30-147			30-209			30-271	
	30-24			30-86			30-148			30-210			30-272	
	30-25			30-87			30-149			30-211			30-273	
	30-26			30-88			30-150			30-212			30-274	
	30-27			30-89			30-151			30-213			30-275	
	30-28			30-90			30-152			30-214			30-276	
	30-29			30-91			30-153			30-215			30-277	
	30-30			30-92			30-154			30-216			30-278	
	30-31			30-93			30-155			30-217			30-279	
	30-32			30-94			30-156			30-218			30-280	
	30-33			30-95			30-157			30-219			30-281	
	30-34			30-96			30-158			30-220			30-282	
	30-35			30-97			30-159			30-221			30-283	
	30-36			30-98			30-160			30-222			30-284	
	30-37			30-99			30-161			30-223				
	30-38			30-100			30-162			30-224			90-1	
	30-39			30-101			30-163			30-225			90-2	
	30-40			30-102			30-164			30-226			90-3	
	30-41			30-103			30-165			30-227			90-4	
	30-42			30-104			30-166			30-228			90-5	
	30-43			30-105			30-167			30-229			90-6	
	30-44			30-106			30-168			30-230				
	30-45			30-107			30-169			30-231				
	30-46			30-108			30-170			30-232				
	30-47			30-109			30-171			30-233				
	30-48			30-110			30-172			30-234				
	30-49			30-111			30-173			30-235				



IMPORTANT SAFETY NOTICE

Proper service and repair is extremely important for the safe operation of your machine. The service and repair techniques recommended by Komatsu Utility and describe in this manual are both effective and safe methods of operation. Some of these operations require the use of tools specially designed by Komatsu Utility for the purpose.

To prevent injury to workers, the symbol  is used to mark safety precautions in this manual. The cautions accompanying these symbols should always be carefully followed. If any danger arises or may possibly arise, first consider safety, and take necessary steps to face.



SAFETY

GENERAL PRECAUTIONS

Mistakes in operation extremely dangerous.
Read all the Operation and Maintenance Manual carefully BEFORE operating the machine.

1. Before carrying out any greasing or repairs, read all the precautions written on the decals which are stuck on the machine.
2. When carrying out any operation, always wear safety shoes and helmet. Do not wear loose work clothes, or clothes with buttons missing.
 - Always wear safety glasses when hitting parts with a hammer.
 - Always wear safety glasses when grinding parts with a grinder, etc.
3. If welding repairs are needed, always have a trained, experienced welder carry out the work. When carrying out welding work, always wear welding gloves, apron, glasses, cap and other clothes suited for welding work.
4. When carrying out any operation with two or more workers, always agree on the operating procedure before starting. Always inform your fellow workers before starting any step of the operation. Before starting work, hang UNDER REPAIR signs on the controls in the operator's compartment.
5. Keep all tools in good condition and learn the correct way to use them.
6. Decide a place in the repair workshop to keep tools and removed parts. Always keep the tools and parts in their correct places. Always keep the work area clean and make sure that there is no dirt or oil on the floor. Smoke only in the areas provided for smoking. Never smoke while working.

PREPARATIONS FOR WORK

7. Before adding or making any repairs, park the machine on hard, level ground, and block the wheels to prevent the machine from moving.
8. Before starting work, lower outrigger, bucket or any other work equipment to the ground. If this is not possible, use blocks to prevent the work equipment from falling down. In addition, be sure to lock all the control levers and hang warning sign on them.
9. When disassembling or assembling, support the machine with blocks, jacks or stands before starting work.
10. Remove all mud and oil from the steps or other places used to get on and off the machine. Always use the handrails, ladders or steps when getting on or off the machine.
Never jump on or off the machine.
If it is impossible to use the handrails, ladders or steps, use a stand to provide safe footing.

PRECAUTIONS DURING WORK

11. When removing the oil filler cap, drain plug or hydraulic pressure measuring plugs, loosen them slowly to prevent the oil from spurting out.
Before disconnecting or removing components of the hydraulic circuit and engine cooling circuit, first remove the pressure completely from the circuit.
12. The water and oil in the circuits are not hot when the engine is stopped, so be careful not to get burned. Wait for the oil water to cool before carrying out any work on the cooling water circuits.
13. Before starting work, remove the leads from the battery. Always remove the lead from the negative (-) terminal first.

14. When raising heavy components, use a hoist or crane. Check that the wire rope, chains and hooks are free from damage.
Always use lifting equipment which has ample capacity. Install the lifting equipment at the correct places.
Use a hoist or crane and operate slowly to prevent the component from hitting any other part.
Do not work with any part still raised by the hoist or crane.
15. When removing covers which are under internal pressure or under pressure from a spring, always leave two bolts in position on opposite sides. Slowly release the pressure, then slowly loosen the bolts to remove.
16. When removing components, be careful not to break or damage the wiring.
Damage wiring may cause electrical fires.
17. When removing piping, stop the fuel or oil from spilling out. If any fuel or oil drips on to the floor, wipe it up immediately.
Fuel or oil on the floor can cause you to slip, or can even start fires.
18. As a general rule, do not use gasoline to wash parts. In particular, use only the minimum of gasoline when washing electrical parts.
19. Be sure to assemble all parts again in their original places. Replace any damage parts with new parts. When installing hoses and wires, be sure that they will not be damaged by contact with other parts when the machine is being operated.
20. When installing high pressure hoses, make sure that they are not twisted. Damaged tubes are dangerous, so be extremely careful when installing tubes for high pressure circuits. Also, check that connecting parts are correctly tightened.
21. When assembling or installing parts, always use specified tightening torques.
When installing the parts which vibrate violently or rotate at high speed, be particularly careful to check that they are correctly installed.
22. When aligning two holes, never insert your fingers or hand.
23. When measuring hydraulic pressure, check that the measuring tool is correctly assembled before taking any measurement.
24. Take care when removing or installing wheels.

FOREWORD

This shop manual has been prepared as an aid to improve the quality of repairs by giving the operator an accurate understanding of the product and by showing him the correct way to perform repairs and make judgements. Make sure you understand the contents of this manual and use it to full effect at every opportunity.

This shop manual mainly contains the necessary technical information for operations performed in a service workshop.

The manual is divided into chapters on each main group of components; these chapters are further divided into the following sections.

STRUCTURE AND FUNCTION

This section explains the structure and function of each component. It serves not only to give an understanding of the structure, but also serves as reference material for troubleshooting.

TESTING AND ADJUSTING

This sections explains checks to be made before and after performing repairs, as well as adjustments to be made at completion of the checks and repairs.

Troubleshooting charts correlating «Problems» to «Causes» are also included in this section.

DISASSEMBLY AND ASSEMBLY

This section explains the order to be followed when removing, installing, disassembling or assembling each component, as well as precautions to be taken for these operations.

NOTE

The specifications contained in this shop manual are subject to change at any time and without any notice.

Contact your Komatsu Utility distributor for the latest information.

HOW TO READ THE SHOP MANUAL

VOLUMES

Shop manual are issued as a guide to carry out repairs. These various volumes are designed to avoid duplicating the same information.

DISTRIBUTION AND UPDATING

Any additions, amendments or other changes will be sent to Komatsu Utility distributors. Get the most up-to-date information before you start any work.

FILING METHOD

1. See the page number on the bottom of the page. File the pages in correct order.
2. Following examples show you how to read the page number. Example:

10 - 3

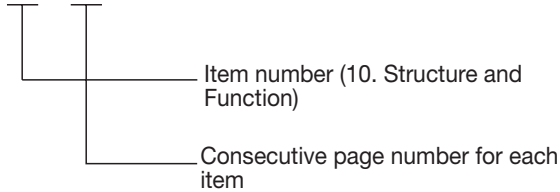

3. Additional pages: additional pages are indicated by a hyphen (-) and number after the page number. File as in the example. Example:

10-4

10-4-1
10-4-2

—Added pages

10-5

REVISED EDITION MARK

When a manual is revised, an edition mark is recorded on the bottom outside corner of the pages.

REVISIONS

Revised pages are shown on the LIST OF REVISED PAGES between the title page and SAFETY page.

SYMBOLS

In order to make the shop manual greatly helpful, important points about safety and quality are marked with the following symbols.

Symbol	Item	Remarks
	Safety	Special safety precautions are necessary when performing the work.
		Extra special safety precautions are necessary when performing the work because it is under internal pressure.
	Caution	Special technical precautions or other precautions for preserving standards are necessary when performing the work.
	Weight	Weight of parts or systems. Caution necessary when selecting hoisting wire, or when working posture is important, etc.
	Tightening torque	Parts that require special attention for the tightening torque during assembly.
	Coat	Parts to be coated with adhesives and lubricants etc.
	Oil, water	Places where oil, water or fuel must be added, and their quantity.
	Drain	Places where oil or water must be drained, and quantity to be drained.

HOISTING INSTRUCTIONS

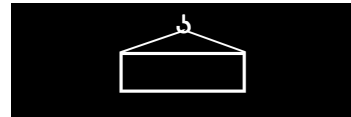

⚠ Heavy parts (25 kg or more) must be lifted with a hoist etc. In the Disassembly and Assembly section, every part weighing 25 kg or more is clearly indicated with the symbol 

- If a part cannot be smoothly removed from the machine by hoisting, the following checks should be made:
 - Check for removal of all bolts fastening the part to the relative parts.
 - Check for any part causing interference with the part to be removed.

2. Wire ropes

- Use adequate ropes depending on the weight of parts to be hoisted, referring to the table below:

WIRE ROPES (Standard «S» or «Z» twist ropes without galvanizing)	
Rope diameter (mm)	Allowable load (tons)
10.0	1.0
11.2	1.4
12.5	1.6
14.0	2.2
16.0	2.8
18.0	3.6
20.0	4.4
22.4	5.6
30.0	10.0
40.0	18.0
50.0	28.0
60.0	40.0

The allowable load value is estimated to be one-sixth or one-seventh of the breaking strength of the rope used.

- Sling wire ropes from the middle portion of the hook. Slings near the edge of the hook may cause the rope to slip off the hook during hoisting, and a serious accident can result.

Hooks have maximum strength at the middle portion.

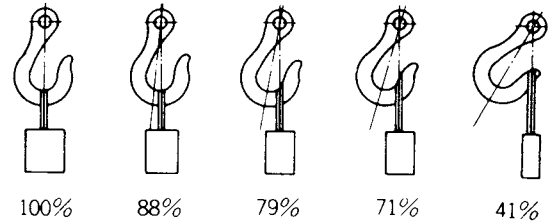

- Do not sling a heavy load with one rope alone, but sling with two or more ropes symmetrically wound on to the load.

⚠ Slings with one rope may cause turning of the load during hoisting, untwisting of the rope, or slipping of the rope from its original winding position on the load, which can cause dangerous accidents.

- Do not sling a heavy load with ropes forming a wide hanging angle from the hook.

When hoisting a load with two or more ropes, the force subjected to each rope will increase with the hanging angles.

The table below shows the variation of allowable load (kg) when hoisting is made with two ropes, each of which is allowed to sling up to 1000 kg vertically, at various hanging angles.

When two ropes sling a load vertically, up to 2000 kg of total weight can be suspended.

This weight becomes 1000 kg when two ropes make a 120° hanging angle.

On the other hand, two ropes are subjected to an excessive force as large as 4000 kg if they sling a 2000 kg load at a lifting angle of 150°.

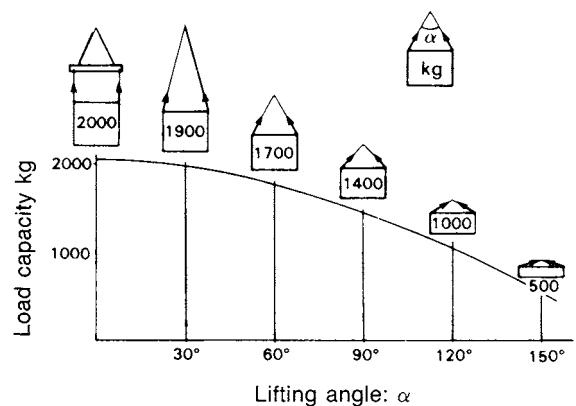





STANDARD TIGHTENING TORQUE

The following charts give the standard tightening torques of bolts and nuts.
Exceptions are given in section of «Disassembly and Assembly».

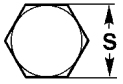
1. STANDARD TIGHTENING TORQUE OF BOLTS AND NUT

Thread diameter of bolts (mm)	Pitch of bolts (mm)	Width across flat (mm)		8.8		10.9	
				kgm	Nm	kgm	Nm
6	1	10	8	0.96±0.1	9.5±1	1.3±0.15	13.5±1.5
8	1.25	13	6	2.3±0.2	23±2	3.2±0.3	32.2±3.5
10	1.5	17	8	4.6±0.5	45±4.9	6.5±0.6	63±6.5
12	1.75	19	10	7.8±0.8	77±8	11±1	108±11
14	2	22	12	12.5±1	122±13	17.5±2	172±18
16	2	24	14	19.5±2	191±21	27±3	268±29
18	2.5	27	14	27±3	262±28	37±4	366±36
20	2.5	30	17	38±4	372±40	53±6	524±57
22	2.5	32	17	52±6	511±57	73±8	719±80
24	3	36	19	66±7	644±70	92±10	905±98
27	3	41	19	96±10	945±100	135±15	1329±140
30	3.5	46	22	131±14	1287±140	184±20	1810±190
33	3.5	50	24	177±20	1740±200	250±27	2455±270
36	4	55	27	230±25	2250±250	320±35	3150±350
39	4	60	—	295±33	2900±330	410±45	4050±450

This torque table does not apply to bolts or nuts which have to fasten nylon or other parts non-ferrous metal washer.

★ Nm (newton meter): 1 Nm = 0.102 kgm



2. TIGHTENING TORQUE FOR NUTS OF FLARED

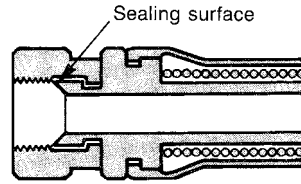

Use these torques for nut part of flared.

Thread diameter of nut part (mm)	Width across flats of nut part (mm)	TIGHTENING TORQUE	
		kgm	Nm
1/2" - 20	17	2.6±0.5	25.5±4.9
9/16" - 18	17	4±0.5	39.2±4.9
3/4" - 16	22	6.7±2	65.7±19.6
7/8" - 14	27	8±2	78.5±19.6
1.1/16 - 12	32	9.7±3	95.15±29.4
1.5/16 - 12	38	17±3	166.7±29.4
1.5/8 - 12	50	20±5	196.2±49
22	27	8±2	78.5±19.6
33	41	20±5	196.2±49

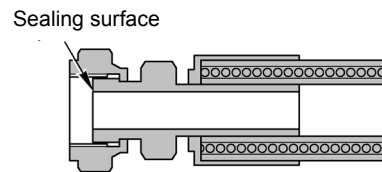

Thread diameter of nut part (mm)	Width across flats of nut part (mm)	TIGHTENING TORQUE	
		kgm	Nm
9/16" - 18	17	2.3-2.5	23-25
11/16" - 16	22	3.4-3.9	33-38
13/16" - 16	24	5.2-5.8	51-57
1" - 14	30	8.2-9.2	80-90
1.3/16 - 12	36	12.2-13.3	120-130
1.7/16 - 12	41	15.3-17.3	150-170
1.11/16 - 12	50	18.4-20.4	180-200
2" - 12	57	20.4-24.4	200-240



COATING MATERIALS

The recommended coating materials prescribed in Komatsu Utility Shop Manuals are listed below:

Nomenclature	Code	Applications
Adhesives	ASL800010	Used to apply rubber pads, rubber gaskets and cork plugs.
	ASL800020	Used to apply resin, rubber, metallic and non-metallic parts when a fast, strong seal is needed.
	Loctite 222	Used for low resistance locking of screws, check nuts and adjustment nuts.
	Loctite 242	To prevent the loosening of bolts, nuts and plugs and the leakage of oil. Used for medium resistance locking of screws and nuts of every type, and for locking keys and bearings.
	Loctite 262	Used for high resistant of threaded parts that can be removed with normal tools.
	Loctite 270	Used for high resistant locking and for sealing threaded parts, bolts and stud bolts.
	Loctite 542	Used for sealing the union threads for hydraulic tubes.
	Loctite 573	Used for sealing rather exact plane surfaces when the option of possible future dismantling is required.
	Loctite 601	Used for high resistant locking of mechanical components that can be removed only after heating
	Loctite 675	Used to lock cylindrical couplings and for the permanent locking of threaded parts, and also to lock shafts to bearings, gears, pulleys, pins, bushings, etc.
Gasket sealant	ASL800060	Used by itself to seal grease fittings, tapered screw fittings and tapered screw fittings in hydraulic circuits of less than 50 mm in diameter.
	Loctite 510	Used by itself on mounting flat surface (Clearance between surfaces within 0.2 mm)
	Loctite 518	Used by itself on mounting flat surface (Clearance between surfaces within 0.5 mm)
Antifriction compound (Lubricant including Molybdenum disulfide)	ASL800040	Applied to bearings and taper shaft to facilitate press-fitting and to prevent sticking, burning or rusting.
Grease (Lithium grease)	ASL800050	Applied to bearings, sliding parts and oil seals for lubrication, rust prevention and facilitation of assembling work.
Vaseline	—	Used for protecting battery electrode terminals from corrosion

ELECTRIC

ELECTRIC

In the wiring diagrams various colour and symbols are employed to indicate the thickness of wires. This wire code table will help you understand WIRING DIAGRAMS.

Example: R-N 1.5 indicates a cable having a nominal number 1.5 and red coating with black stripe.

CLASSIFICATION BY THICKNESS

Nominal number	Copper wire			Cable O.D. (mm)	Current rating (A)
	Number strands	Ø of strands (mm)	Cross section (mm)		
0.5	16	0.20	0.35	1.55	3.5
1	14	0.30	0.99	2.80	11
1.5	21	0.30	1.48	3.35	14
2.5	35	0.30	2.47	3.80	20
4	56	0.30	3.95	4.60	28
6	84	0.30	5.93	5.20	37
10	84	0.40	10.55	7.10	53
50	399	0.40	50.11	14	160

CLASSIFICATION BY COLOUR AND CODE

	Primary	Auxiliary									
Code	A	A-B	A/B	A-G	-	A-N	A/N	A-R	A/R	A-V	A/V
Colour	Light Blue	Light Blue - White		Light Blue-Yellow		Light Blue-Black		Light Blue-Red		Light Blue-Green	
Code	B	B-G	-	B-N	B/N	B-R	B/R	-	B/V	-	-
Colour	White	White-Yellow		White-Black		White-Red		White-Green		-	
Code	C	C-B	C/B	C-L	-	C-N	-	-	-	-	-
Colour	Orange	Orange-White		Orange-Blue		Orange-Black		-		-	
Code	G	G-N	G/N	G-R	-	G-V	-	-	-	-	-
Colour	Yellow	Yellow-Black		Yellow-Red		Yellow-Green		-		-	
Code	H	H-L	-	H-N	H/N	-	-	-	-	-	-
Colour	Grey	Grey-Blue		Grey-Black		-		-		-	
Code	L	L-B	L/B	L-G	-	-	L/N	-	-	-	-
Colour	Blue	Blue-White		Blue-Yellow		Blue-Black		-		-	
Code	M	M-B	-	M-N	M/N	M-V	-	-	-	-	-
Colour	Brown	Brown-White		Brown-Black		Brown-Green		-		-	
Code	N	-	-	-	-	-	-	-	-	-	-
Colour	Black	-		-		-		-		-	
Code	R	R-G	-	R-N	R/N	R-V	-	-	-	-	-
Colour	Red	Red-Yellow		Red-Black		Red-Green		-		-	
Code	S	S-G	-	S-N	-	-	-	-	-	-	-
Colour	Pink	Pink-Yellow		Pink-Black		-		-		-	
Code	V	V-B	-	V-N	V/N	-	-	-	-	-	-
Colour	Green	Green-White		Green-Black		-		-		-	
Code	Z	Z-B	Z/B	Z-N	Z/N	-	-	-	-	-	-
Colour	Violet	Violet-White		Violet-Black		-		-		-	

COMPOSITION OF THE COLOURS

The coloration of two-colour wires is indicated by the composition of the symbol listed.

Example: G-V = Yellow-Green with longitudinal colouring

G/V = Yellow-Green with transversal colouring

WEIGHT TABLE

 This weight table is a guide for use when transporting or handling components.

Unit: kg

Machine model	WH609	WH613	WH713	WH714	WH716
Engine assembly	390.0	390.0	390.0	390.0	390.0
Radiator - exchanger	36.0	36.0	36.0	36.0	36.0
Hydraulic oil tank (empty)	70.0	70.0	86.6	70.0	70.0
Fuel tank (empty)	10.0	10.0	10.0	10.0	10.0
Engine hood	45.0	45.0	45.0	45.0	45.0
Cabin (with seat)	476.0	476.0	476.0	476.0	476.0
Seat	34.0	34.0	34.0	34.0	34.0
Engine-gear box-pump group	672	672	672	672	672
Piston pump	21.6	21.6	21.6	21.6	21.6
Transmission	260.0	260.0	260.0	260.0	260.0
Front axle	436.5	436.5	436.5	436.5	436.5
Rear axle	435.0	435.0	435.0	435.0	435.0
Front wheel Rear wheel	140.0	140.0	140.0	140.0	140.0
Control valve	30.0	30.0	30.0	30.0	30.0
Telescopic arm assembly (2-section boom)	1382.0	–	–	–	–
• Basic boom	523.0	–	–	–	–
• Top boom	510.0	–	–	–	–
Telescopic arm assembly (3-section boom)	–	2112.0	2288.0	2318.0	2588.0
• Basic boom	–	627.0	690.0	690.0	762.0
• Intermediate boom	–	400.0	430.0	430.0	494.0
• Top boom	–	510.0	540.0	540.0	567.0
Outrigger	638.0	638.0	638.0	638.0	638.0
Boom lift cylinder	280.0	280.0	292.0	292.0	292.0
Boom extension cylinder	141.0	217.0	217.0	247.0	370.0
Frame levelling cylinder	–	28.7	28.7	28.7	28.7
Outrigger cylinder	65.2	65.2	65.2	65.2	65.2
Locking axle cylinder	–	35.0	35.0	35.0	35.0
Offset cylinder	32.0	32.0	32.0	32.0	32.0
Bucket cylinder	90.0	90.0	90.0	90.0	90.0

TABLE OF OIL AND COOLANT QUANTITIES

TANK/ RESERVOIR	FLUID	AMBIENT TEMPERATURE										CAPACITY (l)	
		-30	-20	-10	0	10	20	30	40	50 °C	1st filling	Change	
Engine oil pan	In cold climates OIL ACEA E5 - E4	SAE 5W-30										12.8	12.8
	OIL API CH-4 / CI-4 ACEA E5 - E3	SAE 15W-40											
Chains lubrication	ENGINE OIL	SAE 15W-40										as required	as required
Hydraulic system	OIL CF - CF2 - CD	SAE 10W-30										117	95
Hydraulic system with biodegradable oil	see «4.3.1»											117	95
Front axle: Differential	OIL UTTO FLUID											7.1	7.1
Final reduction gear (ea.)												0.7	0.7
Rear axle: Differential												7.1	7.1
Final reduction gear (ea.)												0.7	0.7
Hydraulic transmission	OIL ATF GM DEXRON® II D (DEXRON® is a reg- istered trademark of General Motors Cor- poration)											12.2	10.4
Transmission reduction gear												0.25	0.25
Braking system												0.65	0.65
Fuel tank	DIESEL OIL	*	ASTM D975 N. 2									130	130
Engine cooling system	PERMANENT COOLANT											20	-

* ASTM D975 N. 1

TABLE OF OIL AND COOLANT QUANTITIES

ASTM: America Society of Testing and Materials

SAE: Society of Automotive Engineers

API: American Petroleum Institute

MIL: Military Specification

CCMC: Common Market Constructors Committe

First filling quantity:

total quantity of oil, including the oil for the components and pipes.

Oil change quantity:

quantity of oil necessary to fill the system or unit during the normal inspection and maintenance operations.

NOTE:

- (1) When the diesel oil sulphur content is less then 0.5%, change the engine oil according to the periodic maintenance intervals indicated in the operation and maintenance manual. In the diesel oil sulphur content exceeds 0.5% change the engine oil according to the following table:

Sulphur content	Engine oil change interval
from 0.5 to 1.0%	1/2 of regular interval
over 1.0%	1/4 of regular interval

- (2) When starting the engine at temperatures below 0 °C, use engine oil SAE 10W, 20W-20, even if during the day the temperature increases by 10 °C.
- (3) Use engine oil with CD classification; if oil with CC classification is used, reduce the engine oil change interval by a half.
- (4) Use original products, which have characteristics specifically formulated and approved for the engine, the hydraulic circuit of equipment and for reductions.

CONVERSION TABLE

METHOD OF USING THE CONVERSION TABLE

The conversion table in this section is provided to enable simple conversion of figures. For details of the method of using the conversion table, see the example given below.

EXAMPLE

- Method of using the conversion table to convert from millimeters to inches.

1. Convert 55 mm into inches.

- Locate the number 50 in the vertical column at the left side, take this as **(A)**, then draw a horizontal line from **(A)**.
- Locate the number 5 in the row across the top, take this as **(B)**, then draw a perpendicular line down from **(B)**.
- Take the point where the two lines cross as **(C)**. This point **(C)** gives the value when converting from millimeters to inches. Therefore, 55 mm = 2.165 in.

2. Convert 550 mm into inches

- The number 550 does not appear in the table, so divide by 10 (move the decimal point one place to the left) to convert it to 55 mm.
- Carry out the same procedure as above to convert 55 mm to 2.165 in.
- The original value (550 mm) was divided by 10, so multiply 2.165 in. by 10 (move the decimal point one place to the right) to return to the original value. This gives 550 mm = 21.65 in.

From millimeters to inches

	0	1	2	3	4	5	6	7	8	9
0	0	0.039	0.079	0.118	0.157	0.197	0.236	0.276	0.315	0.354
10	0.394	0.433	0.472	0.512	0.551	0.591	0.630	0.669	0.709	0.748
20	0.787	0.827	0.866	0.906	0.945	0.984	1.024	1.063	1.102	1.142
30	1.181	1.220	1.260	1.299	1.339	1.378	1.417	1.457	1.496	1.536
40	1.575	1.614	1.654	1.693	1.732	1.772	1.811	1.850	1.890	1.929
(A) 50	1.969	2.008	2.047	2.087	2.126	(C) 2.165	2.205	2.244	2.283	2.323
60	2.362	2.402	2.441	2.480	2.520	2.559	2.598	2.638	2.677	2.717
70	2.756	2.795	2.835	2.874	2.913	2.953	2.992	3.032	3.071	3.110
80	3.150	3.189	3.228	3.268	3.307	3.346	3.386	3.425	3.465	3.504
90	3.543	3.583	3.622	3.661	3.701	3.740	3.780	3.819	3.858	3.898

1 mm = 0.03937 in.

From mm to in.

1 mm = 0.03937 in.

	0	1	2	3	4	5	6	7	8	9
0	0	0.039	0.079	0.118	0.157	0.197	0.236	0.276	0.315	0.354
10	0.394	0.433	0.472	0.512	0.551	0.591	0.630	0.669	0.709	0.748
20	0.787	0.827	0.866	0.906	0.945	0.984	1.024	1.063	1.102	1.142
30	1.181	1.220	1.260	1.299	1.339	1.378	1.417	1.457	1.496	1.536
40	1.575	1.614	1.654	1.693	1.732	1.772	1.811	1.850	1.890	1.929
50	1.969	2.008	2.047	2.087	2.126	2.165	2.205	2.244	2.283	2.323
60	2.362	2.402	2.441	2.480	2.520	2.559	2.598	2.638	2.677	2.717
70	2.756	2.795	2.835	2.874	2.913	2.953	2.992	3.032	3.071	3.110
80	3.150	3.189	3.228	3.268	3.307	3.346	3.386	3.425	3.465	3.504
90	3.543	3.583	3.622	3.661	3.701	3.740	3.780	3.819	3.858	3.898

From kg to lb.

1 kg = 2.2046 lb.

	0	1	2	3	4	5	6	7	8	9
0	0	2.20	4.41	6.61	8.82	11.02	13.23	15.43	17.64	19.84
10	22.05	24.25	26.46	28.66	30.86	33.07	35.27	37.48	39.68	41.89
20	44.09	46.30	48.50	50.71	51.91	55.12	57.32	59.53	61.73	63.93
30	66.14	68.34	70.55	72.75	74.96	77.16	79.37	81.57	83.78	85.98
40	88.18	90.39	92.59	94.80	97.00	99.21	101.41	103.62	105.82	108.03
50	110.23	112.44	114.64	116.85	119.05	121.24	123.46	125.66	127.87	130.07
60	132.28	134.48	136.69	138.89	141.10	143.30	145.51	147.71	149.91	152.12
70	154.32	156.53	158.73	160.94	163.14	165.35	167.55	169.76	171.96	174.17
80	176.37	178.57	180.78	182.98	185.19	187.39	189.60	191.80	194.01	196.21
90	198.42	200.62	202.83	205.03	207.24	209.44	211.64	213.85	216.05	218.26

From liter to U.S. Gall.

1 ℓ = 0.2642 U.S. Gall.

	0	1	2	3	4	5	6	7	8	9
0	0	0.264	0.528	0.793	1.057	1.321	1.585	1.849	2.113	2.378
10	2.642	2.906	3.170	3.434	3.698	3.963	4.227	4.491	4.755	5.019
20	5.283	5.548	5.812	6.076	6.340	6.604	6.869	7.133	7.397	7.661
30	7.925	8.189	8.454	8.718	8.982	9.246	9.510	9.774	10.039	10.303
40	10.567	10.831	11.095	11.359	11.624	11.888	12.152	12.416	12.680	12.944
50	13.209	13.473	13.737	14.001	14.265	14.529	14.795	15.058	15.322	15.586
60	15.850	16.115	16.379	16.643	16.907	17.171	17.435	17.700	17.964	18.228
70	18.492	18.756	19.020	19.285	19.549	19.813	20.077	20.341	20.605	20.870
80	21.134	21.398	21.662	21.926	22.190	22.455	22.719	22.983	23.247	23.511
90	23.775	24.040	24.304	24.568	24.832	25.096	25.361	25.625	25.889	26.153

From liter to U.K. Gall.

1 ℓ = 0.21997 U.K. Gall.

	0	1	2	3	4	5	6	7	8	9
0	0	0.220	0.440	0.660	0.880	1.100	1.320	1.540	1.760	1.980
10	2.200	2.420	2.640	2.860	3.080	3.300	3.520	3.740	3.950	4.179
20	4.399	4.619	4.839	5.059	5.279	5.499	5.719	5.939	6.159	6.379
30	6.599	6.819	7.039	7.259	7.479	7.699	7.919	8.139	8.359	8.579
40	8.799	9.019	9.239	9.459	9.679	9.899	10.119	10.339	10.559	10.778
50	10.998	11.281	11.438	11.658	11.878	12.098	12.318	12.528	12.758	12.978
60	13.198	13.418	13.638	13.858	14.078	14.298	14.518	14.738	14.958	15.178
70	15.398	15.618	15.838	16.058	16.278	16.498	16.718	16.938	17.158	17.378
80	17.598	17.818	18.037	18.257	18.477	18.697	18.917	19.137	19.357	19.577
90	19.797	20.017	20.237	20.457	20.677	20.897	21.117	21.337	21.557	21.777

From Nm to lb.ft.

1 Nm = 0.737 lb.ft.

	0	1	2	3	4	5	6	7	8	9
0	0	0.737	1.474	2.211	2.948	3.685	4.422	5.159	5.896	6.633
10	7.370	8.107	8.844	9.581	10.318	11.055	11.792	12.529	13.266	14.003
20	14.740	15.477	16.214	16.951	17.688	18.425	19.162	19.899	20.636	21.373
30	22.110	22.847	23.584	24.321	25.058	25.795	26.532	27.269	28.006	28.743
40	29.480	30.217	30.954	31.691	32.428	33.165	33.902	34.639	35.376	36.113
50	36.850	37.587	38.324	39.061	39.798	40.535	41.272	42.009	42.746	43.483
60	44.220	44.957	45.694	46.431	47.168	47.905	48.642	49.379	50.116	50.853
70	51.590	52.327	53.064	53.801	54.538	55.275	56.012	56.749	57.486	58.223
80	58.960	59.697	60.434	61.171	61.908	62.645	63.382	64.119	64.856	65.593
90	66.330	67.067	67.804	68.541	69.278	70.015	70.752	71.489	72.226	72.963
100	73.700	74.437	75.174	75.911	76.648	77.385	78.122	78.859	79.596	80.333
110	81.070	81.807	82.544	83.281	84.018	84.755	85.492	86.229	86.966	87.703
120	88.440	89.177	89.914	90.651	91.388	92.125	92.862	93.599	94.336	95.073
130	95.810	96.547	97.284	98.021	98.758	99.495	100.232	100.969	101.706	102.443
140	103.180	103.917	104.654	105.391	106.128	106.865	107.602	108.339	109.076	109.813
150	110.550	111.287	112.024	112.761	113.498	114.235	114.972	115.709	116.446	117.183
160	117.920	118.657	119.394	120.131	120.868	121.605	122.342	123.079	123.816	124.553
170	125.290	126.027	126.764	127.501	128.238	128.975	129.712	130.449	131.186	131.923
180	132.660	133.397	134.134	134.871	135.608	136.345	137.082	137.819	138.556	139.293
190	140.030	140.767	141.504	142.241	142.978	143.715	144.452	145.189	145.926	146.663

From Nm to kgm

1 Nm = 0.102 kgm

	0	1	2	3	4	5	6	7	8	9
0	0	0.102	0.204	0.306	0.408	0.510	0.612	0.714	0.816	0.918
10	1.020	1.222	1.224	1.326	1.428	1.530	1.632	1.734	1.836	1.938
20	2.040	2.142	2.244	2.346	2.448	2.550	2.652	2.754	2.856	2.958
30	3.060	3.162	3.264	3.366	3.468	3.570	3.672	3.774	3.876	3.978
40	4.080	4.182	4.284	4.386	4.488	4.590	4.692	4.794	4.896	4.998
50	5.100	5.202	5.304	5.406	5.508	5.610	5.712	5.814	5.916	6.018
60	6.120	6.222	6.324	6.426	6.528	6.630	6.732	6.834	6.936	7.038
70	7.140	7.242	7.344	7.446	7.548	7.650	7.752	7.854	7.956	8.058
80	8.160	8.262	8.364	8.466	8.568	8.670	8.772	8.874	8.976	9.078
90	9.180	9.282	9.384	9.486	9.588	9.690	9.792	9.894	9.996	10.098
100	10.200	10.302	10.404	10.506	10.608	10.710	10.812	10.914	11.016	11.118
110	11.220	11.322	11.424	11.526	11.628	11.730	11.832	11.934	12.036	12.138
120	12.240	12.342	12.444	12.546	12.648	12.750	12.852	12.954	13.056	13.158
130	13.260	13.362	13.464	13.566	13.668	13.770	13.872	13.974	14.076	14.178
140	14.280	14.382	14.484	14.586	14.688	14.790	14.892	14.994	15.096	15.198
150	15.300	15.402	15.504	15.606	15.708	15.810	15.912	16.014	16.116	16.218
160	16.320	16.422	16.524	16.626	16.728	16.830	16.932	17.034	17.136	17.238
170	17.340	17.442	17.544	17.646	17.748	17.850	17.952	18.054	18.156	18.258
180	18.360	18.462	18.564	18.666	18.768	18.870	18.972	19.074	19.176	19.278
190	19.380	19.482	19.584	19.686	19.788	19.890	19.992	20.094	20.196	20.298

From kgm to lb.ft.

1 kgm = 7.233 lb.ft.

	0	1	2	3	4	5	6	7	8	9
0	0	7.2	14.5	21.7	28.9	36.2	43.4	50.6	57.9	65.1
10	72.3	79.6	86.8	94.0	101.3	108.5	115.7	123.0	130.2	137.4
20	144.7	151.9	159.1	166.4	173.6	180.8	188.1	195.3	202.5	209.8
30	217.0	224.2	231.5	238.7	245.9	253.2	260.4	267.6	274.9	282.1
40	289.3	296.6	303.8	311.0	318.3	325.5	332.7	340.0	347.2	354.4
50	361.7	368.9	376.1	383.4	390.6	397.8	405.1	412.3	419.5	426.8
60	434.0	441.2	448.5	455.7	462.9	470.2	477.4	484.6	491.8	499.1
70	506.3	513.5	520.8	528.0	535.2	542.5	549.7	556.9	564.2	571.4
80	578.6	585.9	593.1	600.3	607.6	614.8	622.0	629.3	636.5	643.7
90	651.0	658.2	665.4	672.2	679.9	687.1	694.4	701.6	708.8	716.1
100	723.3	730.5	737.8	745.0	752.2	759.5	766.7	773.9	781.2	788.4
110	795.6	802.9	810.1	817.3	824.6	831.8	839.0	846.3	853.5	860.7
120	868.0	875.2	882.4	889.7	896.9	904.1	911.4	918.6	925.8	933.1
130	940.3	947.5	954.8	962.0	969.2	876.5	983.7	990.9	998.2	1005.4
140	1012.6	1019.9	1027.1	1034.3	1041.5	1048.8	1056.0	1063.2	1070.5	1077.7
150	1084.9	1092.2	1099.4	1106.6	1113.9	1121.1	1128.3	1135.6	1142.8	1150.0
160	1157.3	1164.5	1171.7	1179.0	1186.2	1193.4	1200.7	1207.9	1215.1	1222.4
170	1129.6	1236.8	1244.1	1251.3	1258.5	1265.8	1273.0	1280.1	1287.5	1294.7
180	1301.9	1309.2	1316.4	1323.6	1330.9	1338.1	1345.3	1352.6	1359.8	1367.0
190	1374.3	1381.5	1388.7	1396.0	1403.2	1410.4	1417.7	1424.9	1432.1	1439.4

From bar to psi (lb/in²)

1 bar = 14.503 psi

	0	1	2	3	4	5	6	7	8	9
0	0	14.5	29.0	43.5	58.0	72.5	87.0	101.5	116.0	130.5
10	145.0	159.5	174.0	188.5	203.0	217.5	232.0	246.5	261.0	275.6
20	290.0	304.6	319.1	333.6	348.1	362.6	377.1	391.6	406.1	420.6
30	435.1	449.6	464.1	478.6	493.1	507.6	522.1	536.6	551.1	565.6
40	580.1	594.6	609.1	623.6	638.1	652.6	667.1	681.6	696.1	710.6
50	725.1	739.6	754.1	768.6	783.2	797.7	812.2	826.7	841.2	855.7
60	870.2	884.7	899.2	913.7	928.2	942.7	957.2	971.7	986.2	1000.7
70	1015.2	1029.7	1044.2	1058.7	1073.2	1087.7	1102.2	1116.7	1131.2	1145.7
80	1160.2	1174.7	1189.2	1203.7	1218.2	1232.7	1247.2	1261.8	1276.3	1290.8
90	1305.3	1319.8	1334.3	1348.8	1363.3	1377.8	1392.3	1406.8	1421.3	1435.8
100	1450.3	1464.8	1479.3	1493.8	1508.3	1522.8	1537.3	1551.8	1566.3	1580.8
110	1595.3	1609.8	1624.3	1638.8	1653.3	1667.8	1682.3	1696.8	1711.3	1725.8
120	1740.4	1754.9	1769.4	1783.9	1798.4	1812.9	1827.4	1841.9	1856.4	1870.8
130	1885.4	1899.9	1914.4	1928.9	1943.4	1957.9	1972.4	1986.9	2001.4	2015.9
140	2030.4	2044.9	2059.4	2073.9	2088.4	2102.9	1217.4	2131.9	2146.4	2160.9
150	2175.4	2189.9	2204.4	2218.9	2233.5	2248.0	2262.5	2277.0	2291.5	2306.0
160	2320.5	2335.0	2349.5	2364.0	2378.5	2393.0	2407.5	2422.0	2436.5	2451.0
170	2465.5	2480.0	2494.5	2509.0	2523.5	2538.0	2552.5	2567.0	2581.5	2596.0
180	2610.5	2625.0	2639.5	2654.0	2668.5	2683.0	2697.7	2712.1	2726.6	2641.1
190	2755.6	2770.0	2784.6	2799.1	2813.6	2828.1	2842.6	2857.1	2871.6	2886.1
200	2900.6	2915.1	2929.6	2944.1	2958.6	2973.1	2987.6	3002.1	3016.6	3031.1
210	3045.6	3060.1	3074.6	3089.1	3103.6	3118.1	3132.6	3147.1	3161.6	3176.1
220	3190.7	3205.2	3219.7	3234.2	3248.7	3263.2	3277.7	3192.2	3306.7	3321.2
230	3335.7	3350.2	3364.7	3379.2	3393.7	3408.2	3422.7	3437.2	3451.7	3466.2
240	3480.7	3495.2	3509.7	3524.2	3538.7	3553.2	3567.7	3582.2	3596.7	3611.2

TEMPERATURE

Fahrenheit-Centigrade conversion; a simple way to convert a Fahrenheit temperature reading into a Centigrade temperature reading or vice versa is to enter the accompanying table in the center or boldface column of figures.

These figures refer to the temperature in either Fahrenheit or Centigrade degrees.

If it is desired to convert from Fahrenheit to Centigrade degrees, consider the center column as a table of Fahrenheit temperatures and read the corresponding Centigrade temperature in the column at the left.

If it is desired to convert from Centigrade to Fahrenheit degrees, consider the center column as a table of Centigrade values and read the corresponding Fahrenheit temperature on the right.

1 °C = 33.8°F

°C		°F	°C		°F	°C		°F	°C		°F
-40.4	-40	-40.0	-11.7	11	51.8	7.8	46	144.8	27.2	81	117.8
-37.2	-35	-31.0	-11.1	12	53.6	8.3	47	116.6	27.8	82	179.6
-34.4	-30	-22.0	-10.6	13	55.4	8.9	48	118.4	28.3	83	181.4
-31.7	-25	-13.0	-10.0	14	57.2	9.4	49	120.2	28.9	84	183.2
-28.9	-20	-4.0	-9.4	15	59.0	10.0	50	122.0	29.4	85	185.0
-28.3	-19	-2.2	-8.9	16	60.8	10.6	51	123.8	30.0	86	186.8
-27.8	-18	-0.4	-8.3	17	62.6	11.1	52	125.6	30.6	87	188.6
-27.2	-17	1.4	-7.8	18	64.4	11.7	53	127.4	31.1	88	190.4
-26.7	-16	3.2	-7.2	19	66.2	12.2	54	129.2	31.7	89	192.2
-26.1	-15	5.0	-6.7	20	68.0	12.8	55	131.0	32.2	90	194.0
-25.6	-14	6.8	-6.1	21	69.8	13.3	56	132.8	32.8	91	195.8
-25.0	-13	8.6	-5.6	22	71.6	13.9	57	134.6	33.3	92	197.6
-24.4	-12	10.4	-5.0	23	73.4	14.4	58	136.4	33.9	93	199.4
-23.9	-11	12.2	-4.4	24	75.2	15.0	59	138.2	34.4	94	201.2
-23.3	-10	14.0	-3.9	25	77.0	15.6	60	140.0	35.0	95	203.0
-22.8	-9	15.8	-3.3	26	78.8	16.1	61	141.8	35.6	96	204.8
-22.2	-8	17.6	-2.8	27	80.6	16.7	62	143.6	36.1	97	206.6
-21.7	-7	19.4	-2.2	28	82.4	17.2	63	145.4	36.7	98	208.4
-21.1	-6	21.2	-1.7	29	84.2	17.8	64	147.2	37.2	99	210.2
-20.6	-5	23.0	-1.1	30	86.0	18.3	65	149.0	37.8	100	212.0
-20.0	-4	24.8	-0.6	31	87.8	18.9	66	150.8	40.6	105	221.0
-19.4	-3	26.6	0.0	32	89.6	19.4	67	152.6	43.3	110	230.0
-18.9	-2	28.4	0.6	33	91.4	20.0	68	154.4	46.1	115	239.0
-18.3	-1	30.2	1.1	34	93.2	20.6	69	156.2	48.9	120	248.0
-17.8	0	32.0	1.7	35	95.0	21.1	70	158.0	51.7	125	257.0
-17.2	1	33.8	2.2	36	96.8	21.7	71	159.8	54.4	130	266.0
-16.7	2	35.6	2.8	37	98.6	22.2	72	161.6	57.2	135	275.0
-16.1	3	37.4	3.3	38	100.4	22.8	73	163.4	60.0	140	284.0
-15.6	4	39.2	3.9	39	102.2	23.3	74	165.2	62.7	145	293.0
-15.0	5	41.0	4.4	40	104.0	23.9	75	167.0	65.6	150	302.0
-14.4	6	42.8	5.0	41	105.8	24.4	76	168.8	68.3	155	311.0
-13.9	7	44.6	5.6	42	107.6	25.0	77	170.6	71.1	160	320.0
-13.3	8	46.4	6.1	43	109.4	25.6	78	172.4	73.9	165	329.0
-12.8	9	48.2	6.7	44	111.2	26.1	79	174.2	76.7	170	338.0
-12.2	10	50.0	7.2	45	113.0	26.7	80	176.0	79.4	175	347.0

10 STRUCTURE AND FUNCTION

ENGINE-TRANSMISSION COUPLING	2	HYDRAULIC PUMP	46
POWER TRAIN	3	CONTROL VALVE	50
TRANSMISSION	5	PPC VALVE	51
FRONT AXLE	31	SOLENOID VALVES	54
REAR AXLE	35	SAFETY VALVES	59
BRAKE PUMPS	39	CYLINDERS	66
STEERING SYSTEM (4WS)	40	AIR CONDITIONING SYSTEM	73
STEERING UNIT	44	CLIMATE CONTROL SYSTEM OPERATION	74
HYDRAULIC DIAGRAM	45	ELECTRICAL DIAGRAMS	75

ENGINE-TRANSMISSION COUPLING

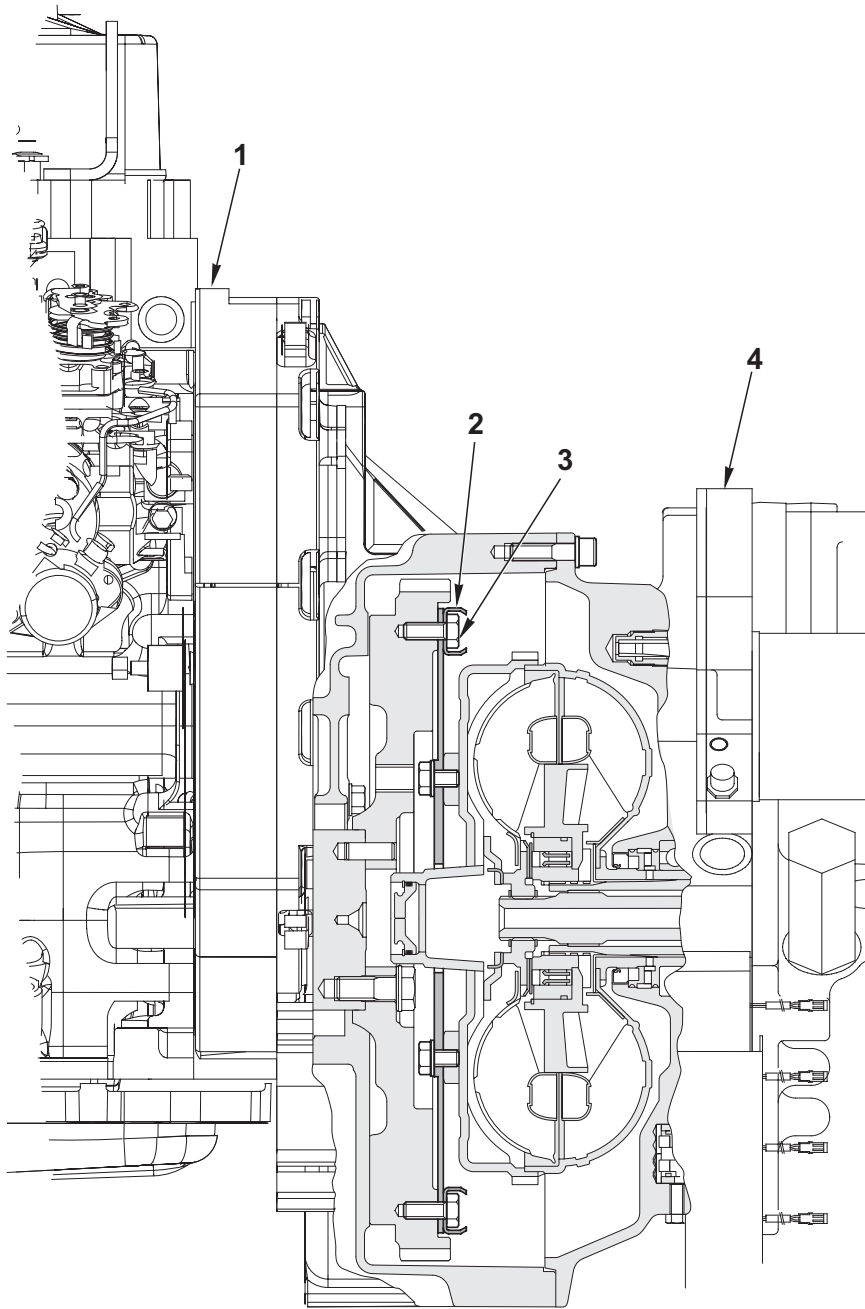

RKT00010

1. Engine
2. Flange
3. Screw
4. Transmission

POWER TRAIN

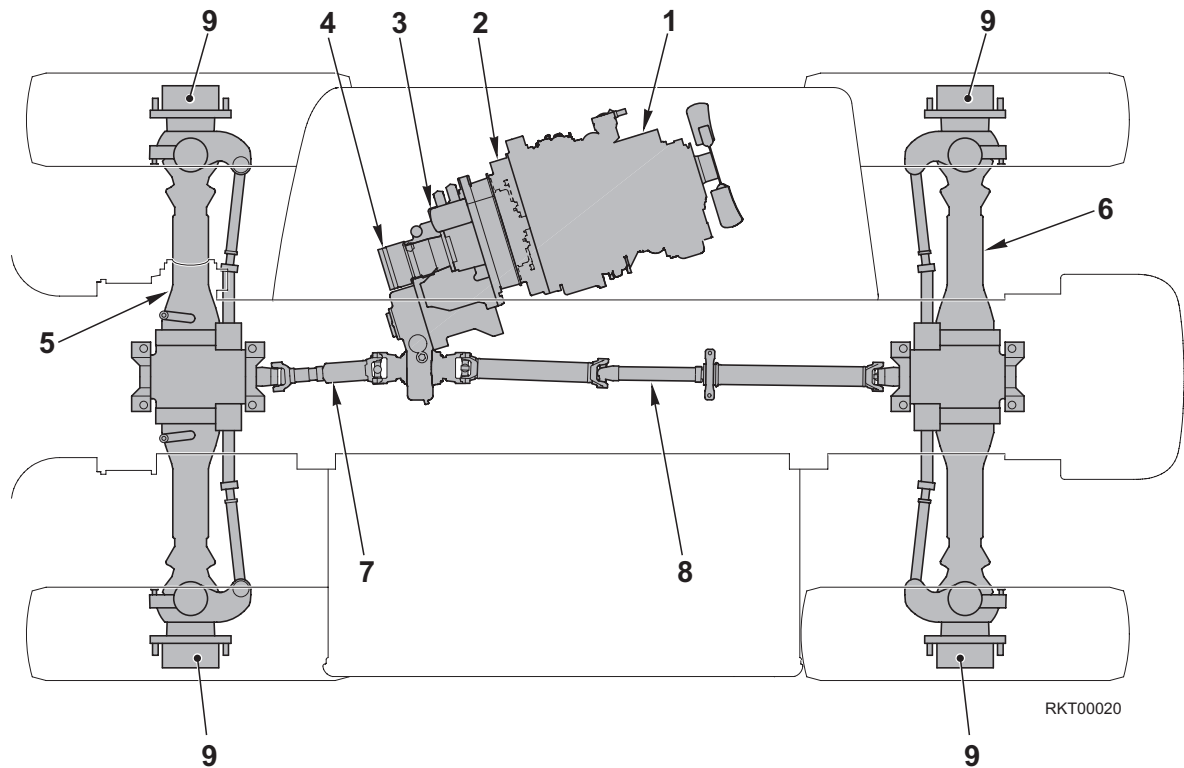

DESCRIPTION

- The driving power generated by the engine (1) is transmitted through the flywheel to the converter (2). The converter uses hydraulic oil to convert the torque transmitted by the engine (1) into driving power. The converter (2) transmits motion to the drive shaft of the transmission (3) and to the drive shaft of the hydraulic pump (4).
- The transmission (3) has two hydraulically-activated clutches that can be selected by an electrically-controlled gear selector.
- The driving power is transmitted from the transmission flanges (3) to the front (5) and rear (6) axles through the cardan drive shafts (7 and 8).
- The driving power transmitted to the front (5) and rear (6) axles is reduced by the differentials and then transmitted to the final drives (9) through the drive shafts.