

Check for Intake and Exhaust Restrictions

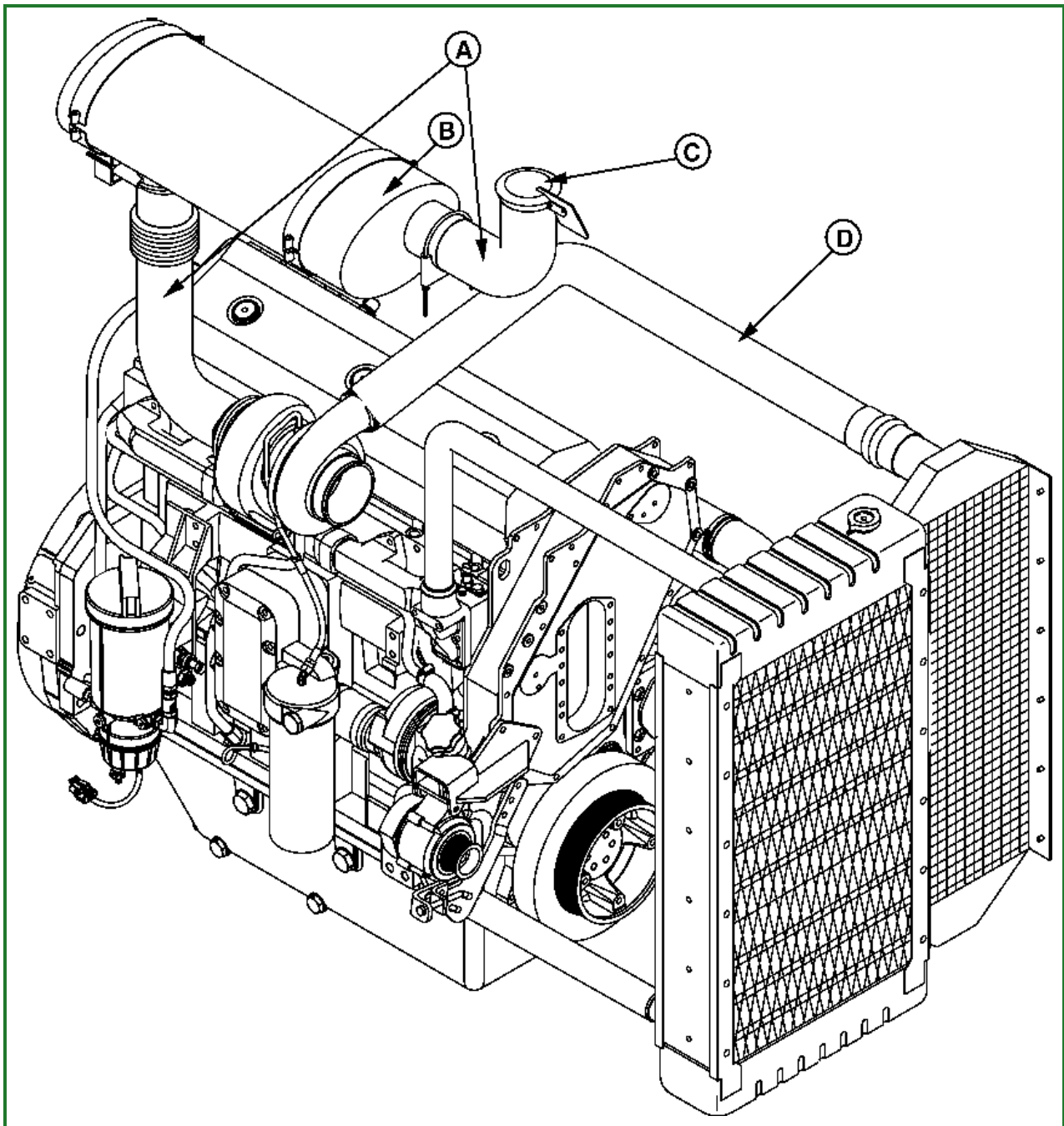

RG10660-UN: Check for Intake and Exhaust Restrictions

LEGEND:

- A - Exhaust piping
- B - Muffler
- C - Rain Cap
- D - Intake Piping

Low power, low boost pressure, and excessive black exhaust smoke can be caused by an intake air or exhaust restriction.

1. Inspect exhaust piping (A), the muffler (B), and the rain cap (C) for damage or any possible restrictions.
2. Inspect the intake piping (D), elbows, and any connections. Look for collapsed pipes, dented pipes and loose connections. Replace components as needed.

[Go to Section_04:Group_150](#)

DPSG, RG40854, 285-19-19990810