

## Replacing Seat Belt

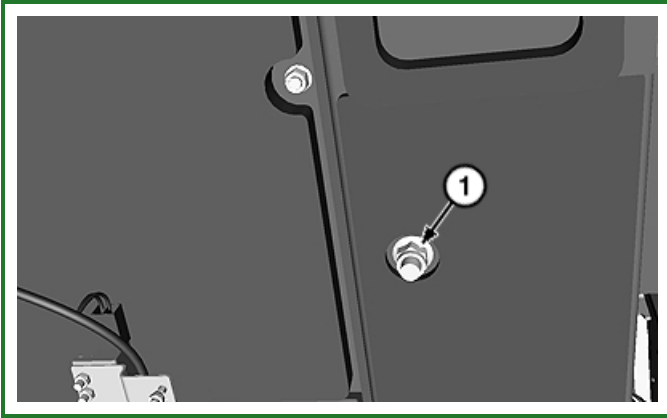

**TX1206595-UN: Lower Shoulder Belt Anchor Nut**

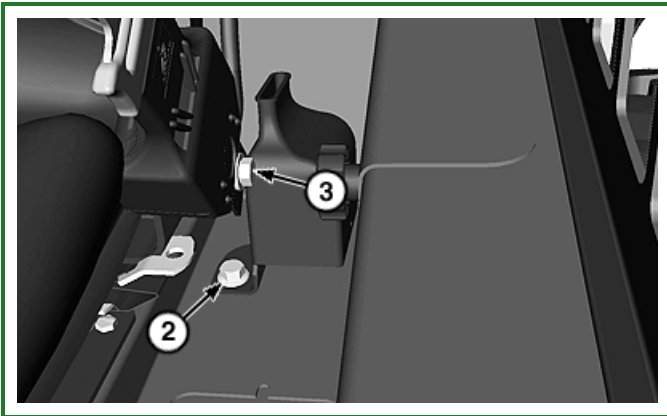

**TX1206596-UN: Seat Belt Anchor**

**LEGEND:**

- 1 - Shoulder Belt Lower Anchor Nut
- 2 - Shoulder Belt Lower Anchor Cap Screw
- 3 - Left Seat Belt-to-Seat Anchor Nut

Examine seat belt frequently. Be sure that webbing is not cut or torn. Replace seat belt immediately if any part is damaged or does not function properly.

***The complete seat belt assembly should be replaced every three years, regardless of appearance.***

**NOTE:**

*Shoulder belt remove and install procedure shown. Lap belt procedure is similar.*

1. Park machine on a level surface.
2. Remove any attachment.
3. Engage park brake and stop engine.
4. Raise and lock operator's station. See Raising Operator's Station. (Section 3-2.)
5. Remove shoulder belt lower anchor nut (1).
6. Lower operator's station.

7. Slide seat forward.
8. Remove shoulder belt lower anchor cap screw (2).
9. Remove left seat belt-to-seat anchor nut (3).
10. Remove right seat belt latch-to-seat anchor nut (4).

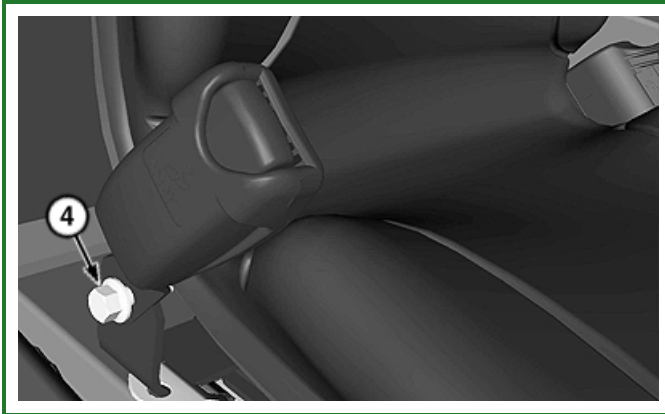

**TX1206597-UN: Seat Belt Latch**

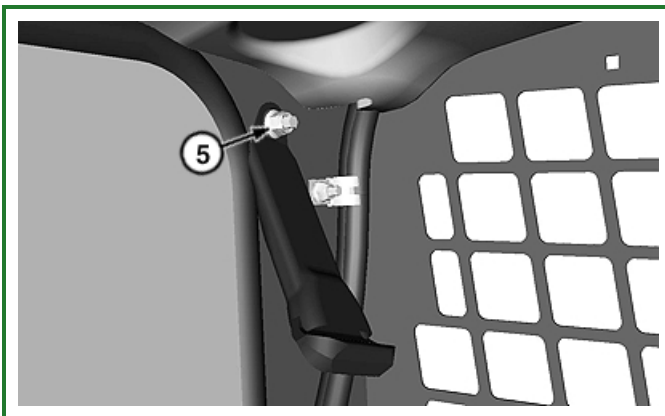

**TX1206598-UN: Shoulder Belt Upper Anchor**

**LEGEND:**

4 - Right Seat Belt Latch-to-Seat Anchor Nut

5 - Shoulder Belt Upper Anchor Nut

11. Remove shoulder belt upper anchor nut (5).
12. Remove seat belt.
13. Clean and inspect parts. Repair or replace as necessary.
14. Install right seat belt latch-to-seat anchor nut.
15. Install left seat belt-to-seat anchor nut.
16. Install shoulder belt upper anchor nut.
17. Lower operator's station. See Raising Operator's Station. (Section 3-2.)
18. Install shoulder belt lower anchor nut.