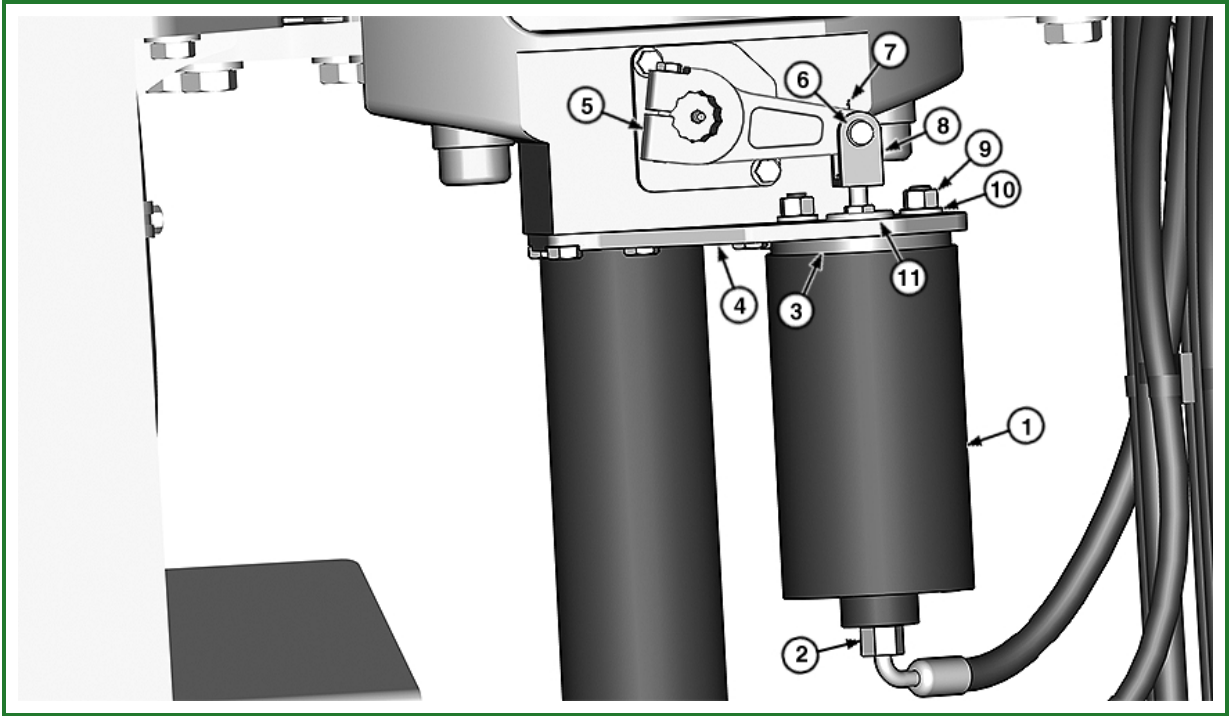

2.

**TX1231585A-UN: Park Brake Chamber****LEGEND:**

- 1 - Chamber
- 2 - Hydraulic Line
- 3 - Spacer
- 4 - Mounting Bracket
- 5 - Lever Arm
- 6 - Clevis Pin
- 7 - Cotter Pin
- 8 - Clevis Assembly
- 9 - Nut (2 used)
- 10 - Washer (2 used)
- 11 - Boot

Remove cotter pin (7) and clevis pin (6).

3. Remove clevis assembly (8) from lever arm (5).
4. Remove nuts (9) and washers (10) from mounting bracket (4).
5. Remove chamber, spacer (3), and boot (11) from mounting bracket.
6. Repair or replace parts as necessary.

INSTALLATION

Installation is reverse of removal procedure.

- Verify park brake operation. [See Parking the Machine](#) . (Operator's Manual.)

Go to [Section_11:Group_1111](#)

RG24095,0000139-19-20170130

Section 16: Electrical System

Group 1600: Removal and Installation

Installation of Repair Wire Assembly (RWA)

TPM—Tire Pressure Sensor Remove and Install

Controllers Remove and Install

Strain Gauge Remove and Install

Connector Terminal Test

Replace (Push-Type) Metri-Pack® Connectors

Replace Metri-Pack® Connectors

Replace DEUTSCH® Circular Connectors

Replace DEUTSCH® Rectangular or Triangular Connectors

Install DEUTSCH® Contact

Replace Weather Pack™ Connector

Install Weather Pack™ Contact

Replace Cinch™ Connectors

Install Cinch™ Contact

Repair 32 and 48-Way Cinch™ Connectors