

Reference 260-20-003, Steering System Theory

Start-up - No Turn

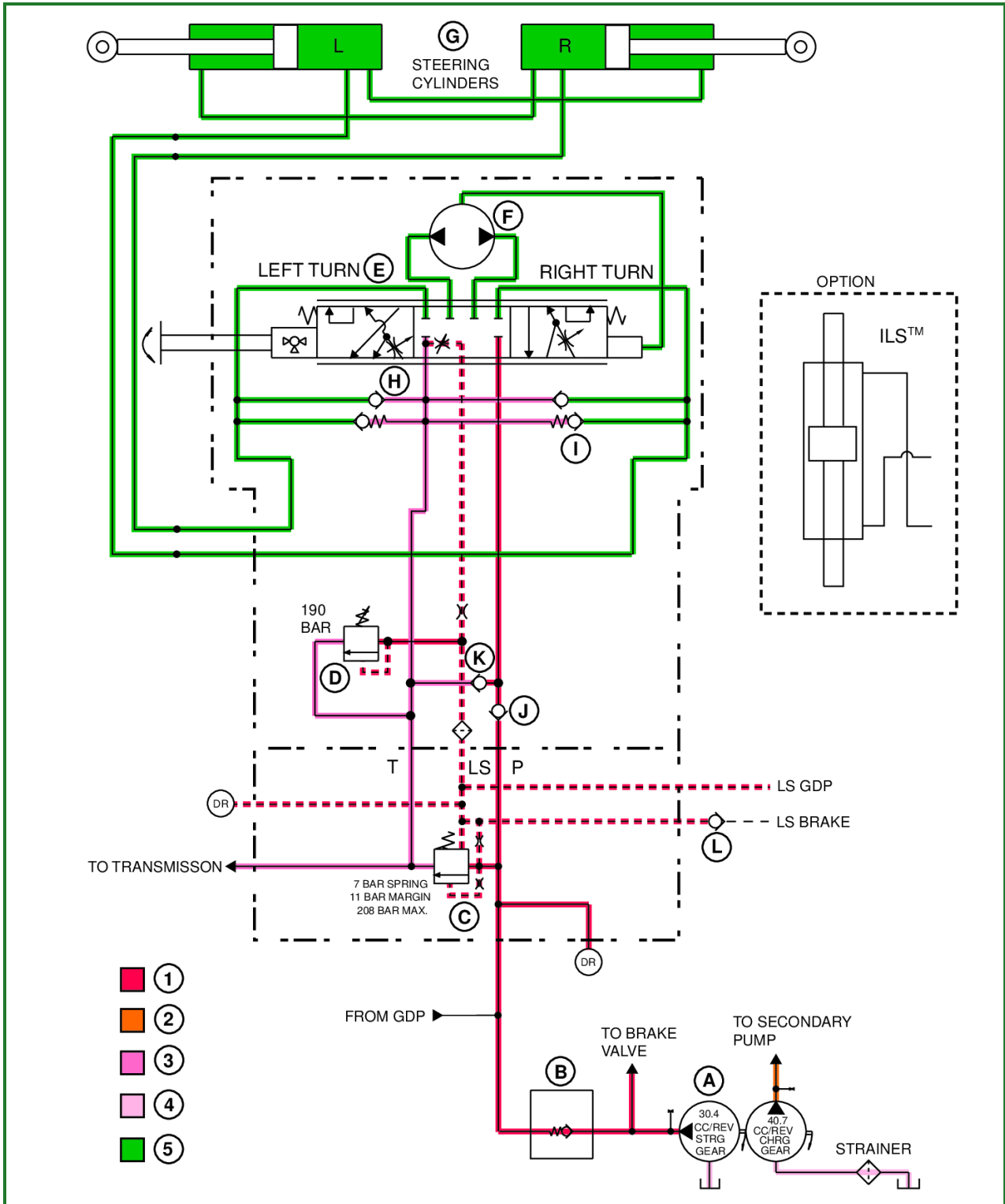

RXA0053978-UN: Start-up - No Turn

LEGEND:

- A - Primary Pump
- B - Steering System Check Valve
- C - Priority Valve
- D - Load Sense Relief Valve
- E - Valve Spool and Sleeve
- F - Gerotor
- G - Steering Cylinders

- H - Anti-Cavitation Check Valve
- I - Cylinder Relief Valve
- J - Steering Inlet Check Valve
- K - Recirculating Check Valve
- L - Brake Load Sense Check Valve
- 1 - High Pressure
- 2 - Charge Pressure
- 3 - Medium Pressure
- 4 - Suction
- 5 - Trapped Oil

