

Install Rear Horizontal Folding Auger

⚠ CAUTION:

Use proper lifting device to install auger.

1. Position auger in tube.

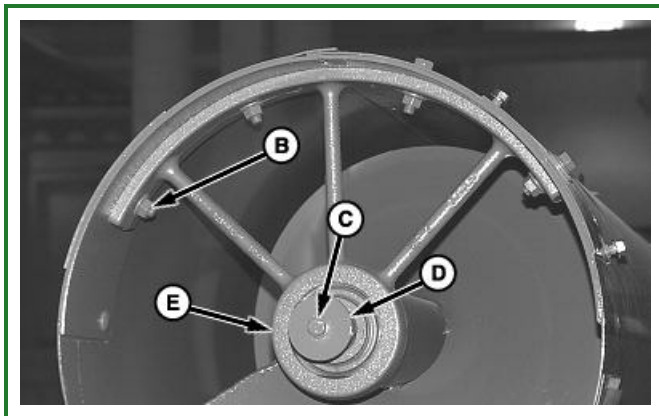

H77363-UN: Bearing Support

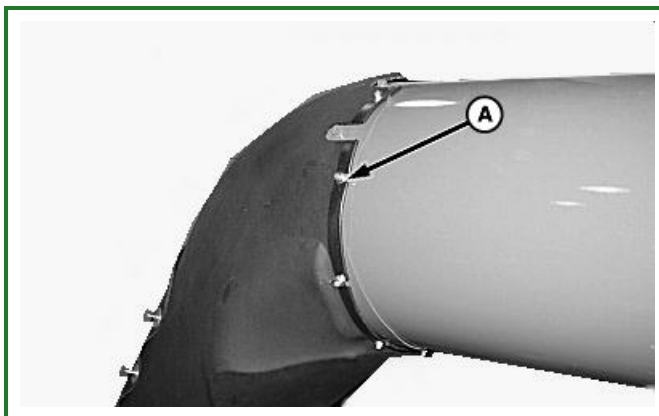

H77355-UN: Unloading Auger Boot

LEGEND:

- A - Nuts (8 used)
- B - Cap Screw and nut (4 used)
- C - Cap Screw
- D - Washer
- E - Support

2. Install support (E) using cap screws (B and C) and washer (D).
3. Install grain saver door. (See REMOVE AND INSTALL UNLOADING AUGER GRAIN SAVER DOOR in this group.)
4. Install boot and tighten nuts (A).

Go to [Section_130:Group_20](#)

OUO6083,0000AD9-19-20050721

Remove Horizontal Auger Gear Case

1. Swing auger to unload position. Shut off engine and remove key.

2.

NOTE:

*Auger can be pushed to rear of tube without separating front and rear auger sections.
This will eliminate the need to time auger flighting upon assembly.*

Slide horizontal auger out of tube enough to access gear case. Do not separate. (See REMOVE HORIZONTAL AUGER in this group.)

3. Remove attaching hardware (A) and grease cap (B).

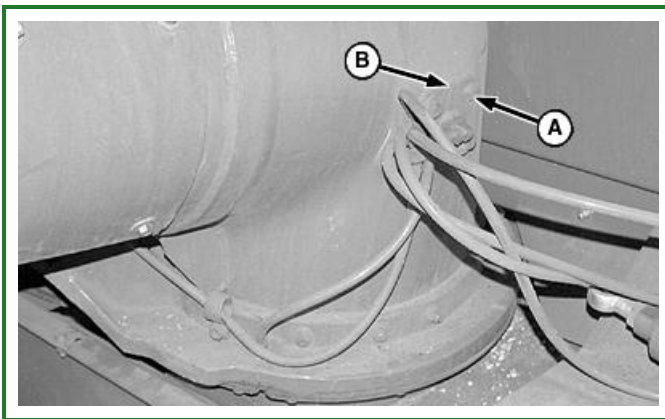

H55090-UN: Horizontal Auger Grease Cap

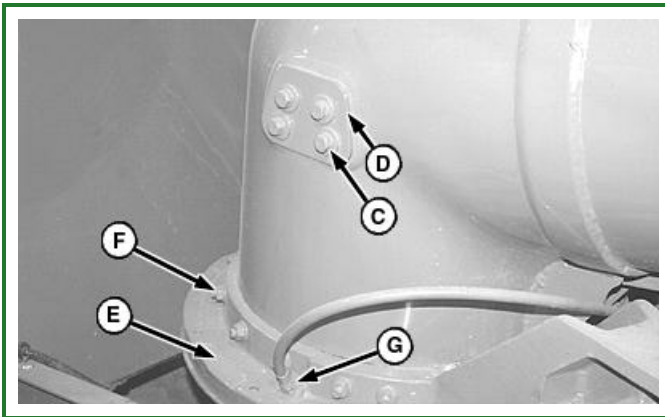

H55091-UN: Horizontal Auger Access Cap

LEGEND:

- A - Attaching Hardware
- B - Grease Cap
- C - Attaching Hardware
- D - Access Cap
- E - Ring
- F - Round Head Bolts
- G - Lubrication Line

4. Remove attaching hardware (C) and access cap (D).
5. Remove gear case through inspection hole.